

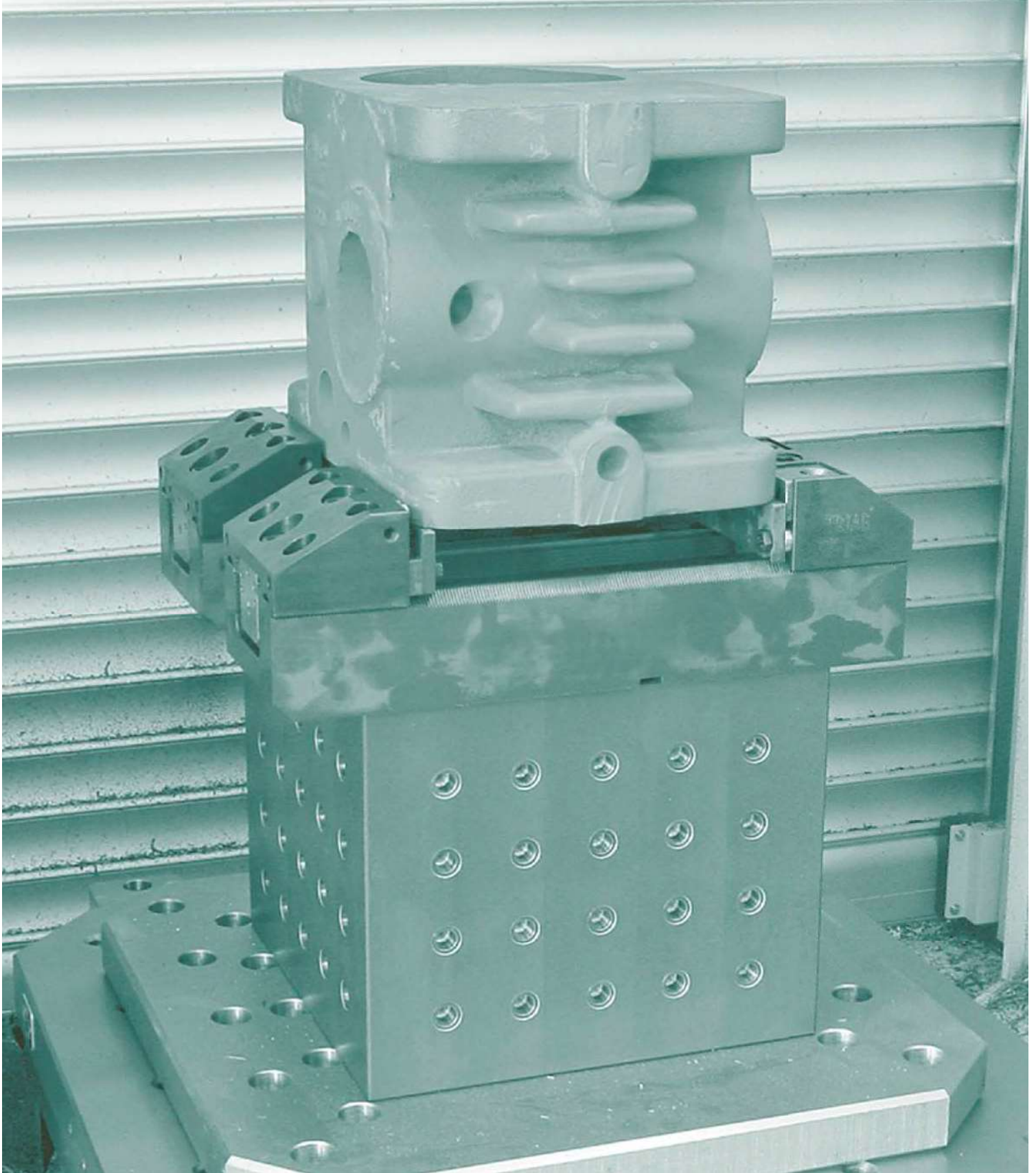



# *apto*CLAMP & 5axes





	<b>Einleitung   Introduction</b> .....	<b>209 - 212</b>
	<b>Bedienungsanleitung   Operating manual</b> .....	<b>213 - 214</b>
	<b>Anwendungsbeispiele   Examples of application</b> .....	<b>215 - 220</b>
	<b>Basisschiene   Base-rail</b> .....	<b>222</b>
		
	<b>Niederzugspannmodule   Pull down clamp modules</b> .....	<b>223 - 226</b>
		
	<b>Linearspannmodule mit Präge- und Linearbacken</b> <b>Linear clamping modules with stamping and linear jaws</b> .....	<b>227</b>
		
	<b>Anschlagmodule   End module</b> .....	<b>228 - 230</b>
		
	<b>5-Achs Linearanschlagmodule mit Präge- und Linearbacken</b> <b>5-axis linear clamping modules with stamping and linear jaws</b> .....	<b>231</b>
		
	<b>Zubehör   Accessories</b> .....	<b>232 - 233</b>
		

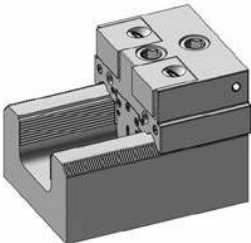
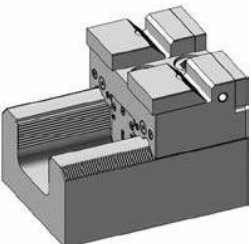
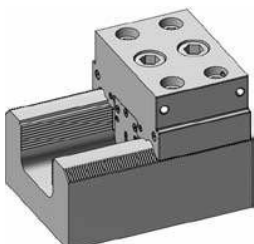
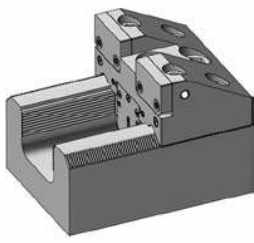
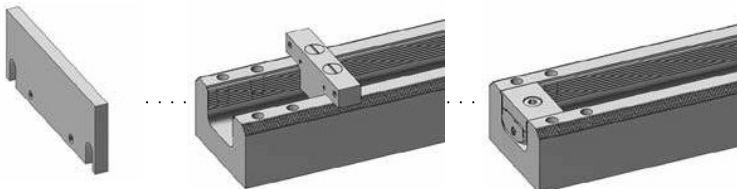

Die hohe Spannkraft dieses Systems ermöglicht den Einsatz für schwere Zerspanung.

Mit stabilen Kraftspannern können auf den Basisschienen auch grosse, bis zu mehrere tausend Kilogramm schwere Platten und Blöcke gespannt werden.

*The high clamping force of the Apto Clamp enables heavy cuts. You achieve maximum rigidity with our Apto Clamp modular system! Even if your workpiece is thousands of kilograms you don't have to worry to clamp big parts and big plates.*

**Elefantenstark und anwenderfreundlich**  
**Powerful and user-friendly**

Zur Positionierung der Spannmodule hat das Apto Clamp neben einer Querverzahnung zusätzlich ein Ankersystem zur Arretierung an einer Längsverzahnung in der Basischiene. Durch die rechtwinklige Verkeilung wird eine von Mitbewerbern unerreichte Stabilität gewährleistet. Die Spannmodule liegen auf der genau geschliffenen Auflagefläche der Basis auf. Durch das Ankersystem und die geschliffene Auflagefläche wird das Spannmodul an der Basisschiene extrem kraftschlüssig und präzise fixiert. Trotzdem können die Spannmodule völlig ungehindert entlang der Basis verstellt (verschoben) werden. Auch das Auswechseln der Module ist einfach, müssen doch diese nicht aus der Schiene ausgefahren, sondern können abgehoben werden.

*For positioning the clamp modules on the base rails, has the Apto Clamp system next to a positioning serration a horizontal anchor system for locking with enornes force produced by two M16 screws. The end modules have additionally 4 M12 screws to give extra rigidity.*



Darum haben wir dieses Symbol gewählt:  
 That's why we have chosen this symbol:



**Schnelligkeit / Quickness**



**Zwei Schraube lösen**  
*Loosen two screws*



**Abheben und neu platzieren**  
*Lift and change position*



**Zwei Schrauben anziehen**  
*Fasten two screws*

**Vorteile auf einen Blick / Benefits at a glance:**

- ➔ Sehr stabil, robuste Bauweise, dadurch hohe Präzision  
*Very stable, robust design allows high precision and heavy machining*
- ➔ Module nach oben abhebbar, kein Ausfahren nötig  
*Modules can be lifted up, no extension needed*
- ➔ Keine verschmutzbaren T-Nuten: Formschlüssig positioniert  
*No chip loading T-slots grooves: Positively positioned*
- ➔ Verzahnung nicht dem Werkstück ausgesetzt  
*The teeth are not exposed to the workpiece*
- ➔ Niederzug- und Linearspannung möglich  
*Pull-down and linear clamping possible*
- ➔ Spannkraft bis 7000 daN pro Modul  
*Clamping force up to 7000 daN per module*

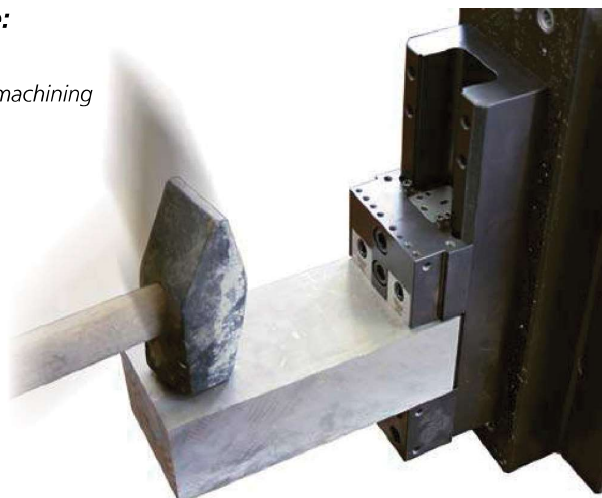

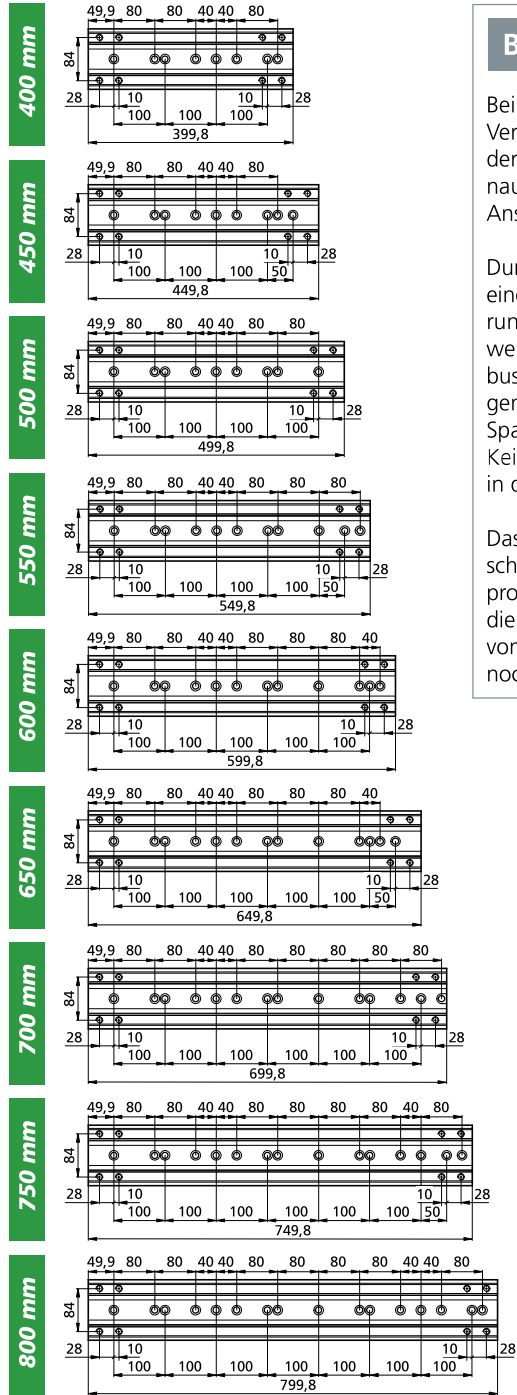

### Basisschiene / Base rail

Beim Apto Clamp ermöglicht eine Verzahnung mit 2 mm-Teilung auf der Basisschiene ein schnelles und genaues Positionieren der Spann- und Anschlagmodule.

*With the new Apto Clamp a serration of 2mm pitch on the base rail allows a rapid and accurate positioning of the modules.*

Durch gezielte elastische Deformation einer Lippe erfolgt eine spielfreie Paarung. Spann- und Bearbeitungskräfte werden einerseits an der ebenen, robusten Oberseite der Basisschiene aufgenommen, während andererseits das Spannmodul durch einen spreizenden Keil mit robustem Rundgewindeprofil in der Schiene verankert wird.

*The outstanding development is that through elastic deformation of a lip, the engagement between the modules and the base rail is without play. Clamping and machining forces are absorbed on the upper surface of the base rail whereas the vice module is fixed to the rail by an expandable anchor which engages the round serration inside the base rail.*

Das Einfügen zusätzlicher Module zwischen bestehenden Spannstellen ist problemlos möglich. Apto Clamp ist die konsequente Weiterentwicklung von Power Clamp zur Bearbeitung noch grösserer Werkstücke.

*The insertion of additional vice modules can be accomplished without problems. Apto Clamp is the logical development of Power Clamp to handle even larger work pieces.*

Schnittzeichnung Sectional view of the base rail

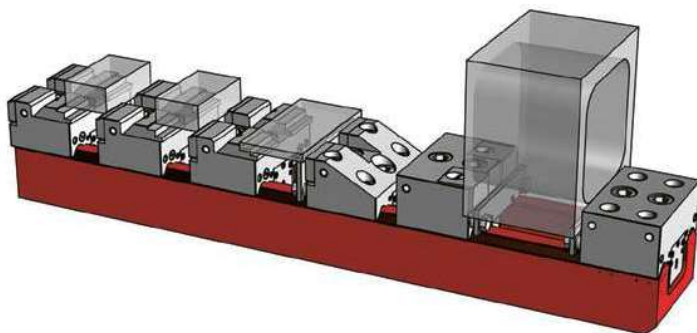
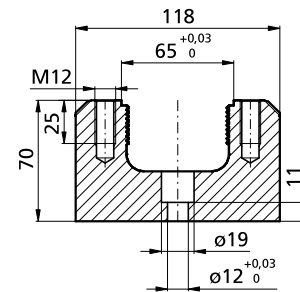



**Das Anschlagmodul / End modules**

In der Regel ist nur ein Anschlagmodul als „feste Backe“ erforderlich.

*In general, only a stop module is required as a „fixed jaw.“*

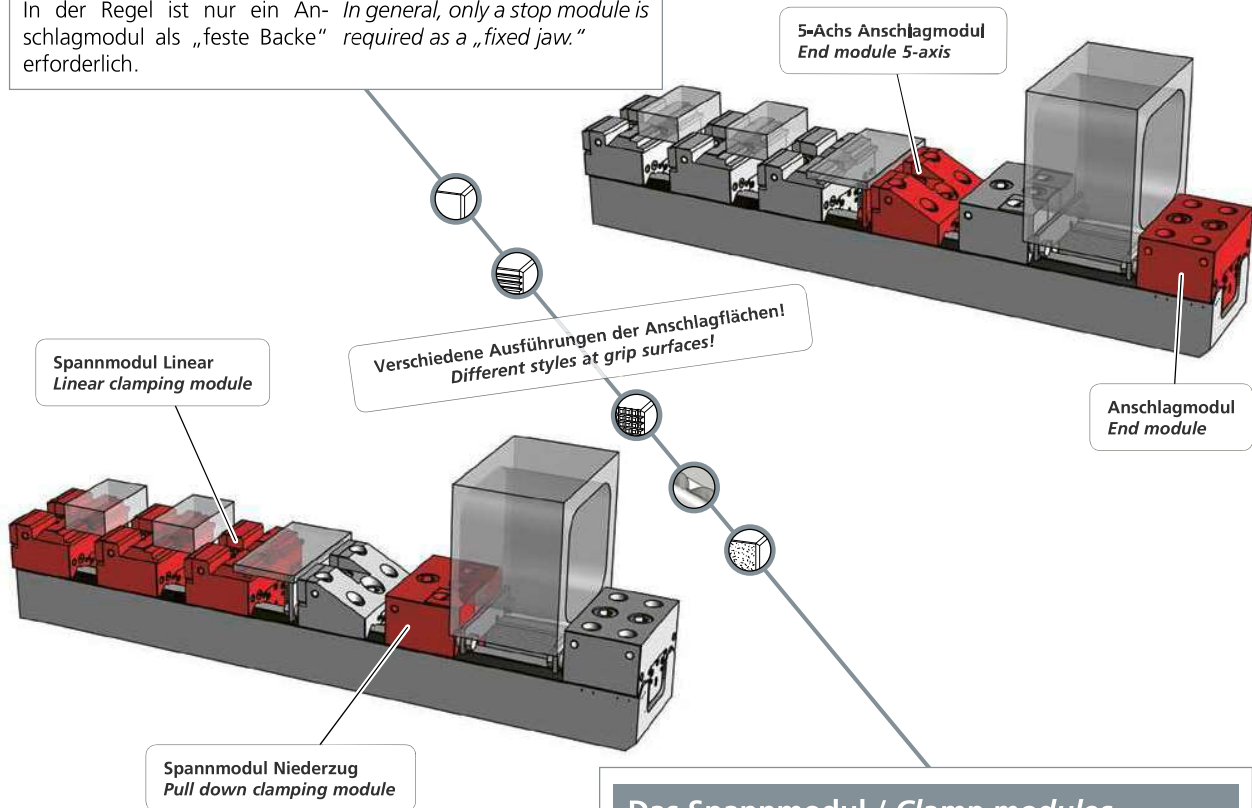

**Das Spannmodul / Clamp modules**

Die «beweglichen Backen» gibt es in zwei Ausführungen. Zum einen für das Niederzugspannsystem und zum anderen für das Linearspannsystem. Dabei dient das Spannmodul bei den Systemen wiederum als Anschlagmodul für die nächste Aufspannung.

*Clampe modules have movable jaws (linear or pull down) in the front to clamp the part and on the back there is the datum face for the next work piece stop. Positioning step on the base rail is 2mm every.*

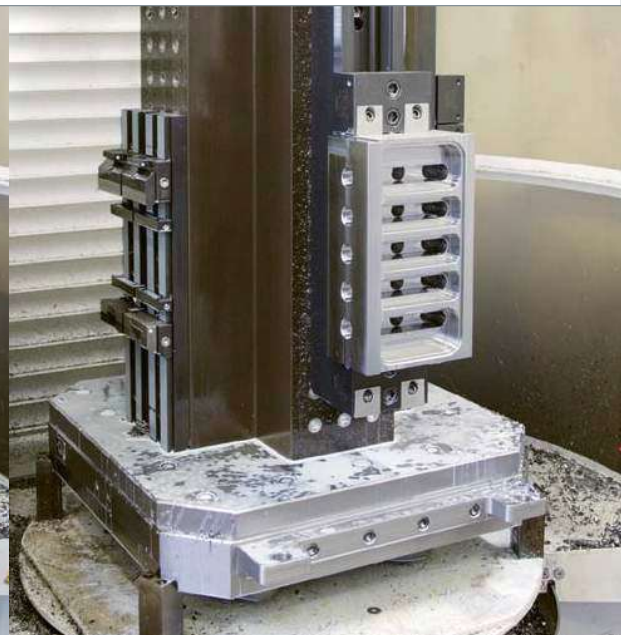



**Niederzugspannmodule**  
*Pull down clamp modules*

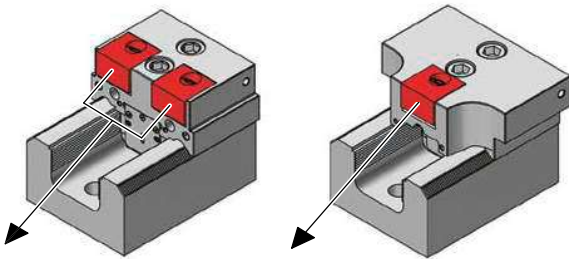

**Die Fakten beim Niederzugspannsystem**

Verstellbereich: 0- 3,8 mm  
 Spannkraft: Bis 7'000 daN

**Vorteile beim Niederzugspannsystem:**

- Höhere Haltekräfte
- Hohe Wiederholgenauigkeit
- Optimale Spannmethode für Kleinteile
- Mit Schnellwechselbacken
- Doppelspannsystem in einer Backe zum Spannen und Bearbeiten von zwei Kleinteilen

**Facts for pull down clamp modules**

Jaw range: 0- 3,8 mm  
 Clamping force: up to 7'000 daN

**Advantages pull down jaws:**

- Higher holding force
- With linear adaptable jaws
- Also with pull down jaws for the stop side available
- With adapter set can be changed to linear
- Also pull down jaws for datum face

**Linearspannmodule**  
*Linear clamp modules*

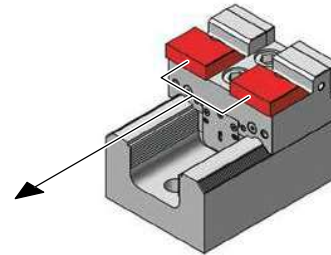

**Die Fakten beim Linearpannsystem**

Verstellbereich: 0- 5,0 mm  
 Spannkraft: Bis 3'200 daN

**Vorteile beim Linearpannsystem:**

- Spannstockähnliches Spannen
- Prozesssichere Positionierung der zweiten Aufspannung
- Gut geeignet für die Erstellung von individuellen Formbacken
- Sicherer Halt mit Prägetechnik

**Facts for linear clamp modules**

Jaw range: 0- 5,0 mm  
 Clamping force: up to 3'200 daN

**Advantages linear jaws:**

- Similar clamp as conventional vise
- Good for shaped jaws
- Secure clamped with direct stamping jaws
- Higher accuracy

**Universalnutenstein**  
*Universal nut*

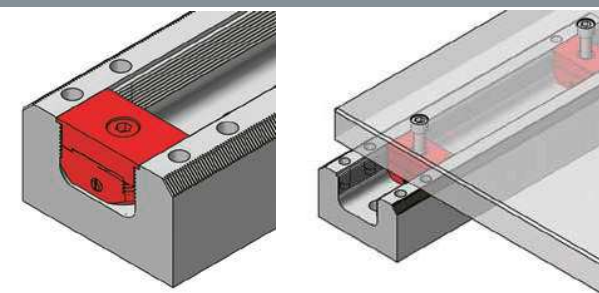

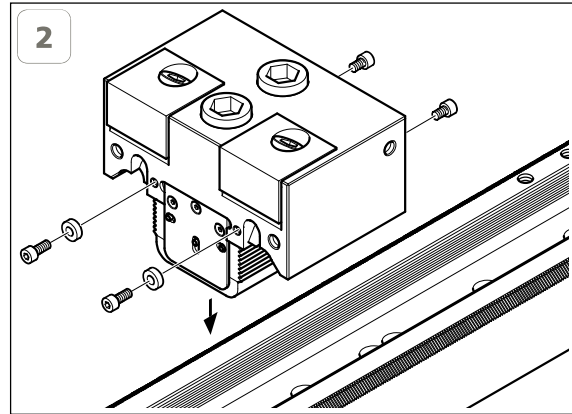
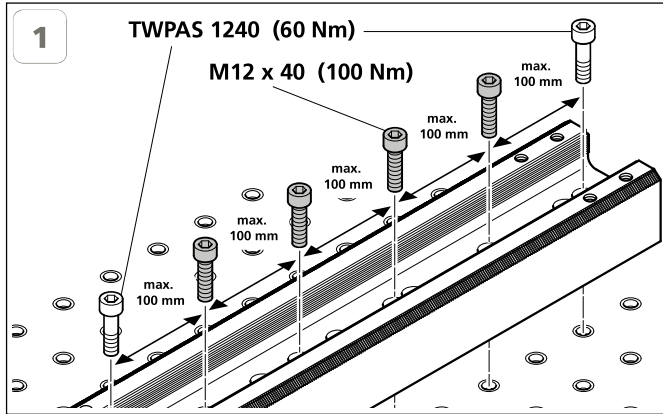

Ineinandergreifen der Verzahnung prüfen  
Check matching of the teeth

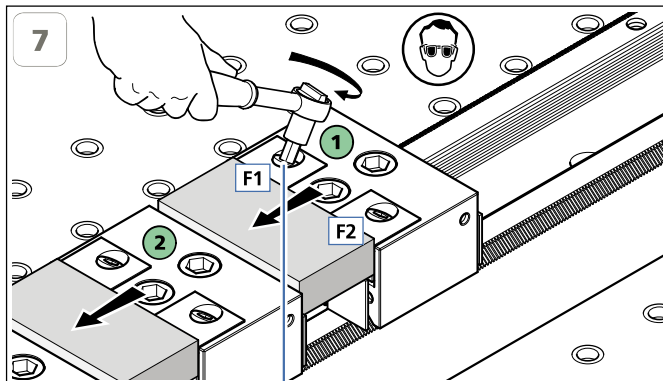
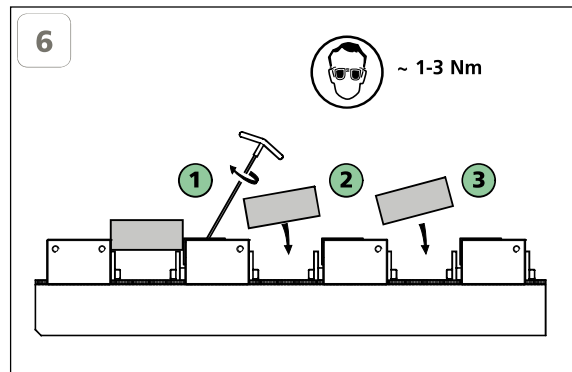
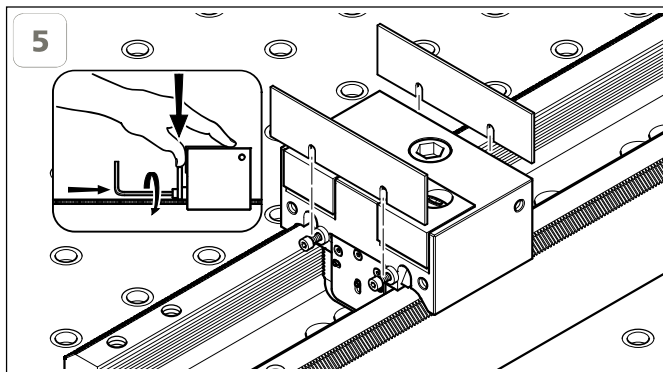
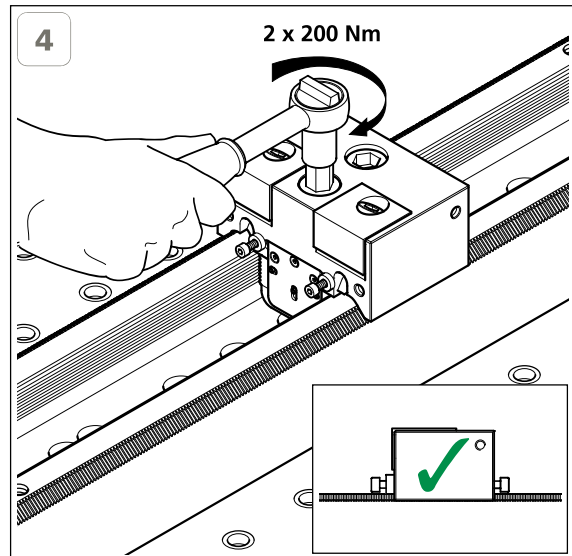
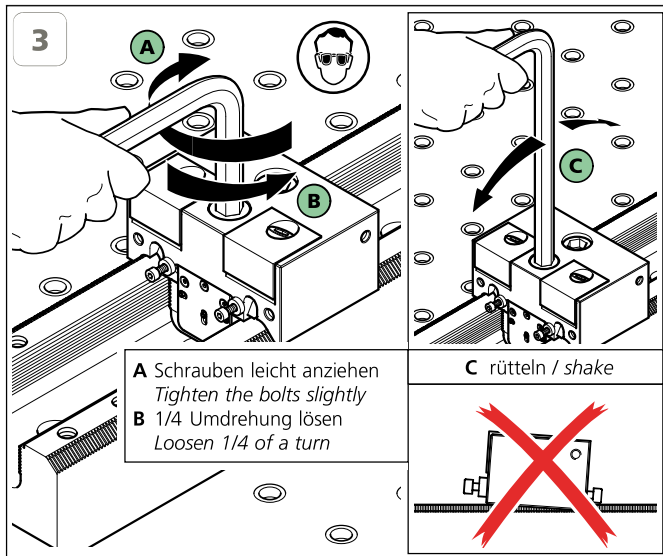

max. Drehmoment beachten  
Observe max. torque

Schraube Screw	Drehmoment Torque		Spannkraft (F1 & F2) Workholding force (F1 & F2)		
	Nm	(lb-ft)	~daN	~(lb)	~t
M10	10	7,4	= 1200	2'650	1,2
	20	14,8	= 2700	5'950	2,7
	30	22,2	= 4100	9'040	4,1
	40	29,5	= 5600	12'350	5,6
	50	37,0	= 7000	15'430	7,0



### ACHTUNG / CAUTION

**WICHTIG:** Die angegebenen Drehmomente sind die absoluten Maximalwerte. Über die Spannkräfte gibt die untenstehende Tabelle Auskunft.

**IMPORTANT:** The torque numbers specified represent the absolute maximum. The table at the bottom of this page provides further information on the workholding forces.

Schraube Screw	Drehmoment Torque		Spannkraft (F1 & F2) Workholding force (F1 & F2)		
	Nm	(lb-ft)	~daN	~(lb)	~t
M10	10	7,4	= 1200	2'650	1,2
	20	14,8	= 2700	5'950	2,7
	30	22,2	= 4100	9'040	4,1
	40	29,5	= 5600	12'350	5,6
	50	37,0	= 7000	15'430	7,0

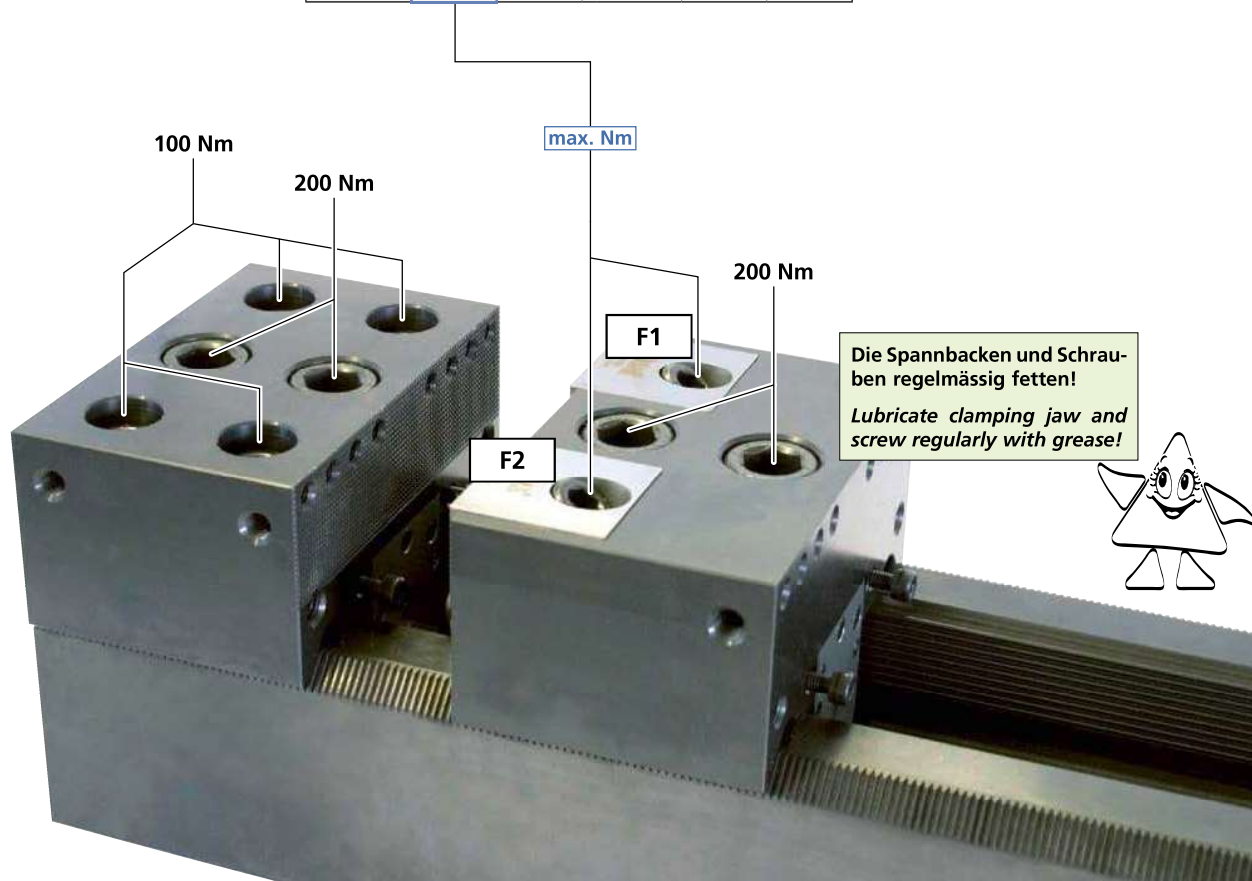

**WICHTIG:**

Vor dem Positionieren der Spannmodule für ein neues Werkstück ist die Spannbacke ganz zurück zu stellen, dies gewährleistet eine sichere Spannung (siehe Bild A)!

**IMPORTANT:**

Prior to setting up a new clamping module the clamping jaw of the vice module must be retracted all the way (see picture A)! This guaranties proper clamping of the new workpiece.

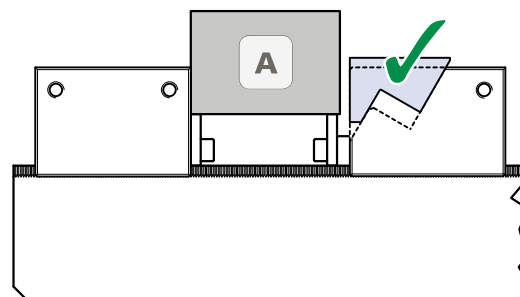
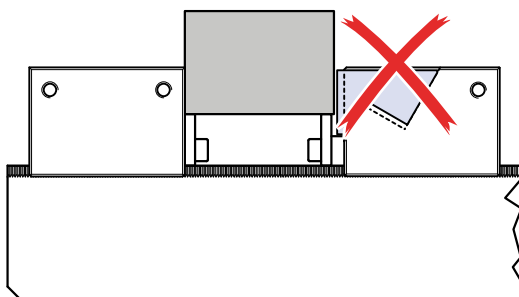



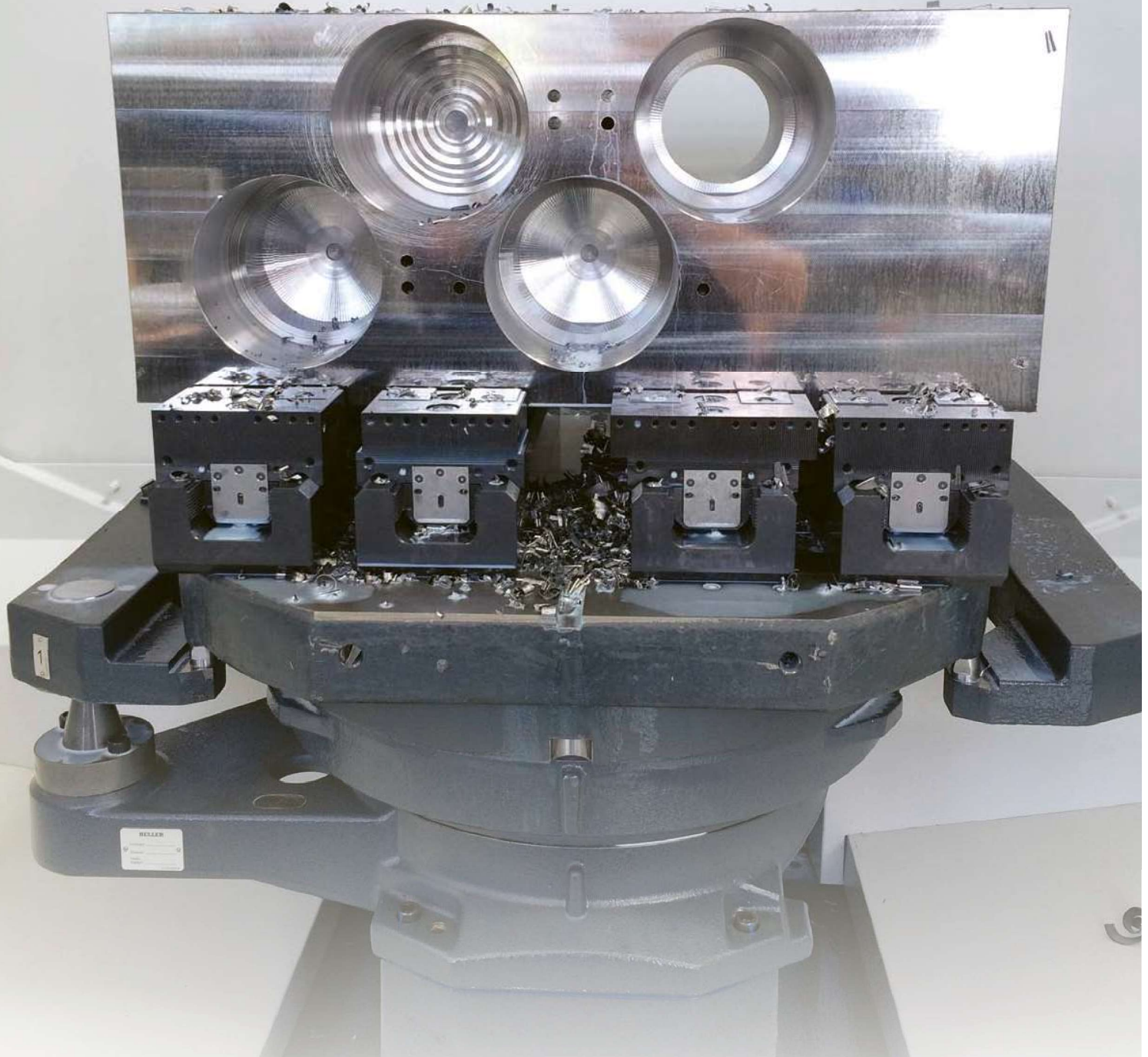

Material	42Cr Mo4
Bearbeitung mit Fräskopf <i>Machining with milling head</i>	Ø 200
Bohrer / Drills	Ø 124
Einspanntiefe / Clamping depth	24mm

**Apto Clamp in der Schwerzerspannung auf Heller 5-Achsen-Maschine**  
*Apto Clamp for heavy duty machining on a 5-axis machine*



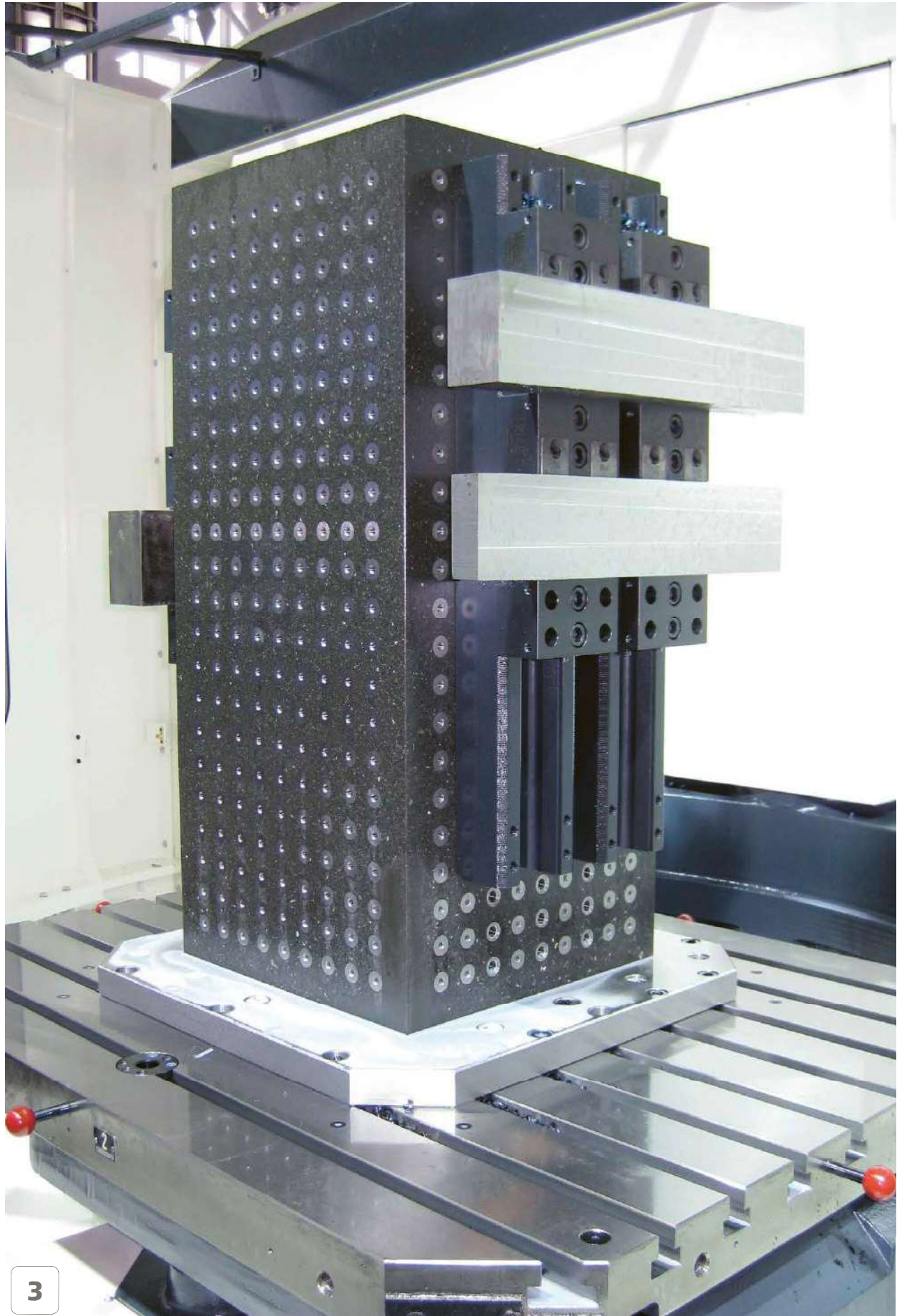

3

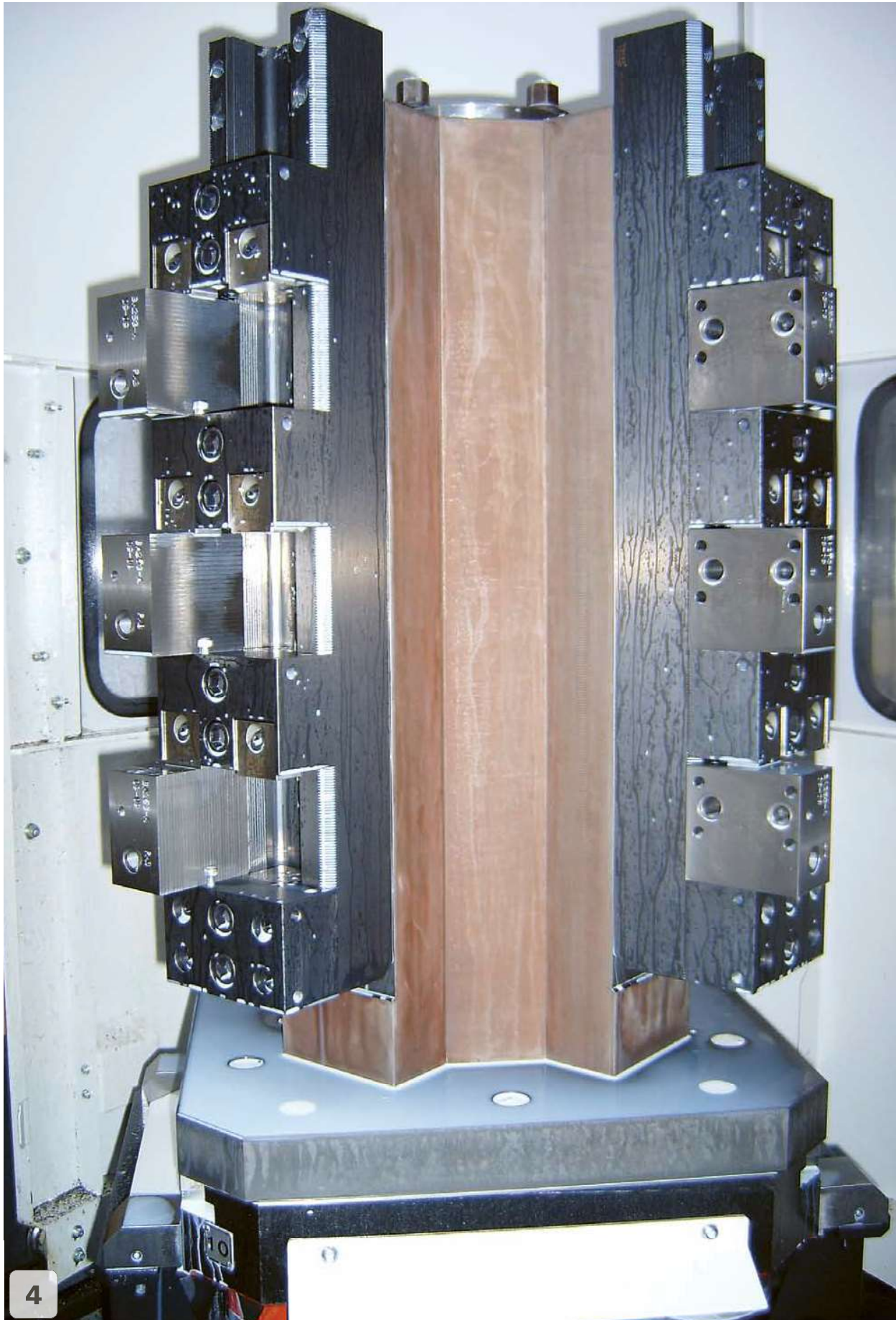

4

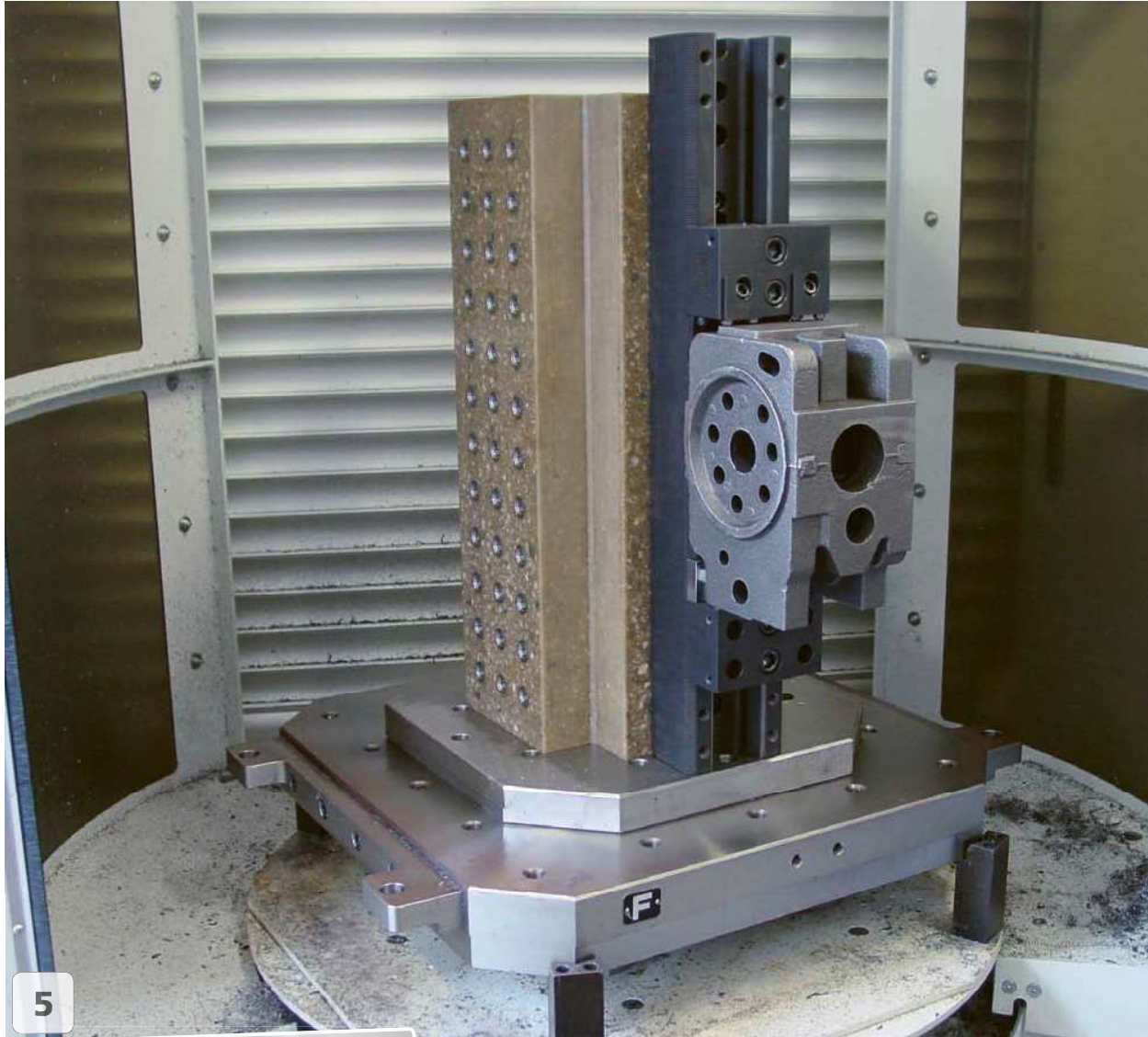

5

**VERTICAL** (3-4 ACHSEN/AXES)

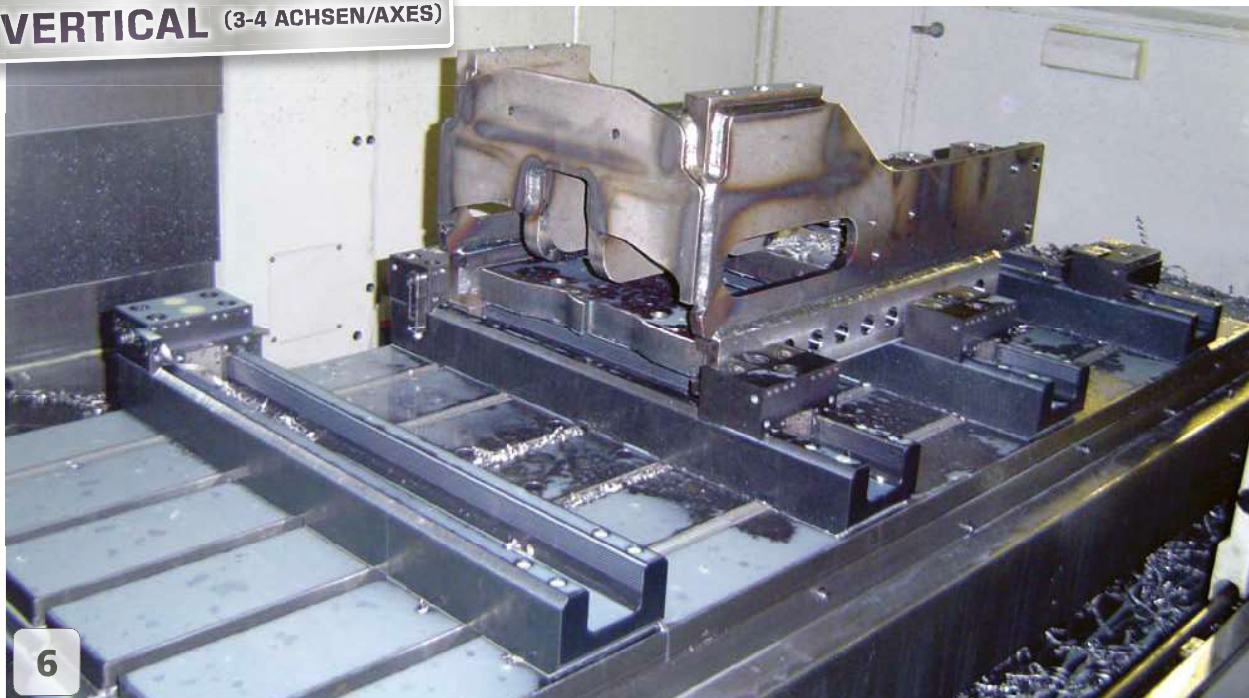

6



## 5axes aptoCLAMP

Es gibt zusätzlich Apto Clamp Module in angeschrägter Ausführung. Damit kann ein optimaler Zugang zum Werkstück bei der 5-Achsenmaschine gewährleistet werden. Die Spannmodule produzieren bis zu 7000 daN (7 Tonnen) Spannkraft und sind für die Schwerzerspannung empfohlen.

*We offer Apto Clamp modules in slanted version. That ensures an optimal access to the workpieces on 5-axis machines. The clamping modules produce up to 7000 daN (7 tons) clamping force and are recommended for heavy roughing workholding.*

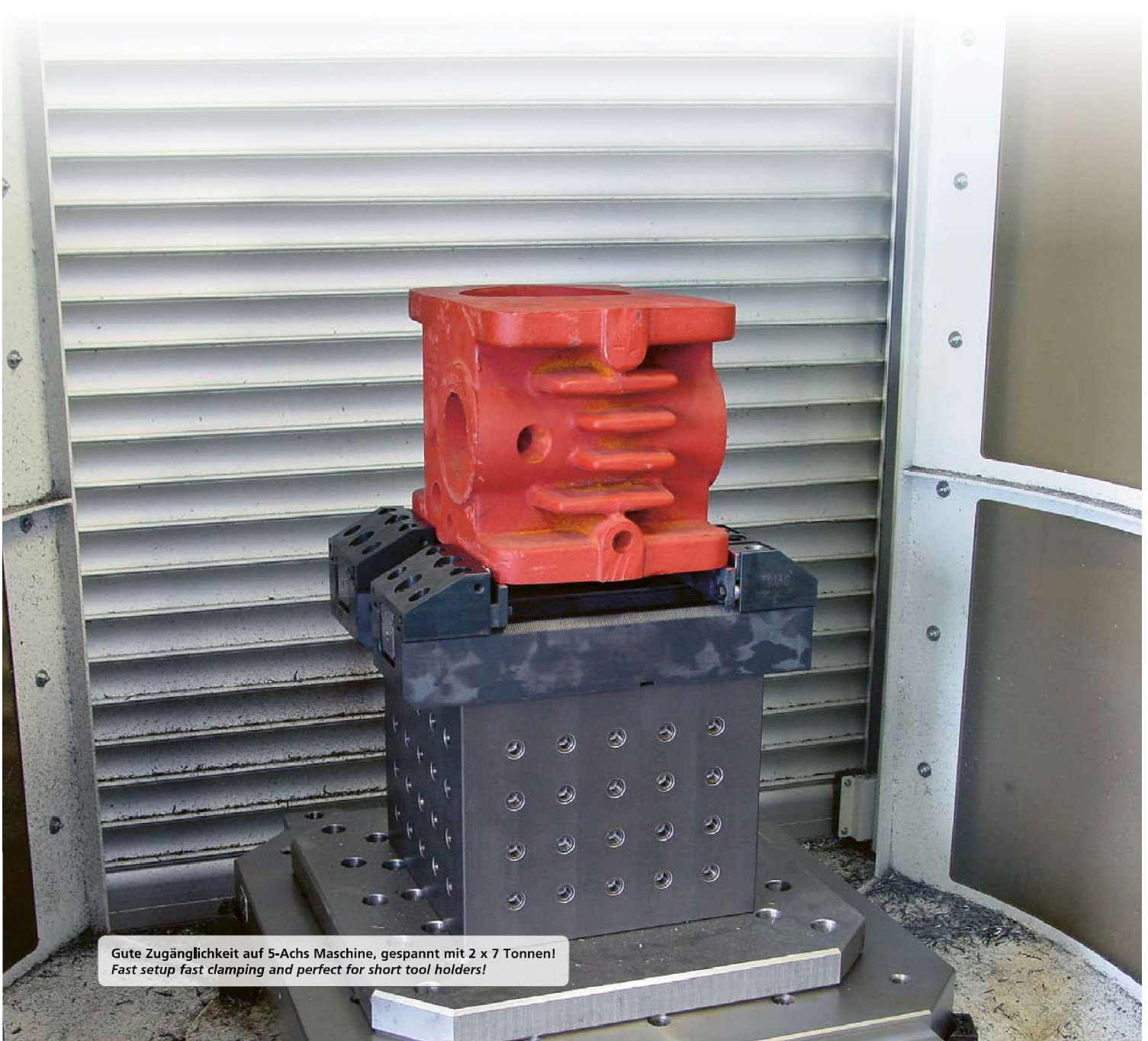

**Gute Zugänglichkeit auf 5-Achs Maschine, gespannt mit 2 x 7 Tonnen!  
Fast setup fast clamping and perfect for short tool holders!**



System System		bei Anschlagmodulen for end module	Modulnutzbreite Module clamping width	Modulnutzhöhe Module clamping height
A	Apto Clamp	N nitriergelärtet nitrated		
P	Power Clamp	D durchgehärtet through hardened		
C	Compact Clamp	<b>bei Spannmodulen for vice modules</b>		
M	Micro Clamp	1 Anzahl Spannbacken Number of jaws		
V	Vorrichtungsbaumodule Workholding modules for dedicated fixtures	2 3		

**A S 2 R 115 N 50 -80**

Modultyp Type of module	
A	Anschlagmodul End module
S	Spannmodul Clamping module
T	Trägermodul Supporting module
R	Rohling Blank

Anschlagfläche der Module Datum face	
F	Anschlagfläche glatt Datum face flat
R	Anschlagfläche geriffelt Datum face double serrated
D	eine Seite glatt, eine Seite geriffelt one face flat, one face double serrated
G	Anschlagfläche gerillt Datum face serrated
X	spezielle Ausführung special execution
5X	5axes Clamp

Backenhub Stroke of clamping jaw	
N	Niederzug Pull down
L	linear / parallel linear / parallel
-	ohne Spannbacke no clamping jaw

Spannbackentyp Type of clamping jaw	
B80 - B89	Spannbacke Clamping jaw
-80 - -105	Modul ohne Spannbacken Module without clamping jaw



ACB4050400 kg ~18

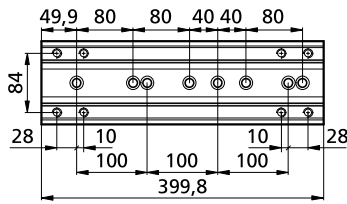

ACB4050700 kg ~31

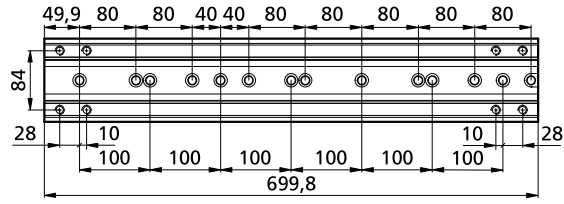

ACB4050450 kg ~20

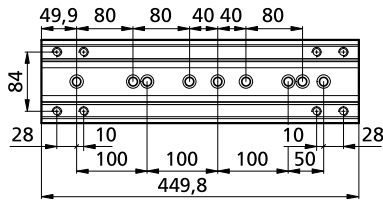

ACB4050750 kg ~33

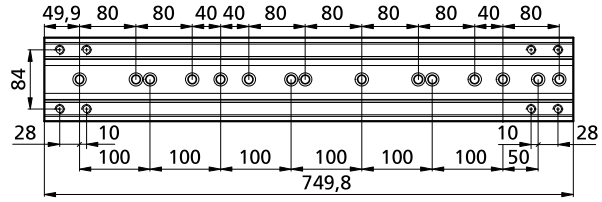

ACB4050500 kg ~22

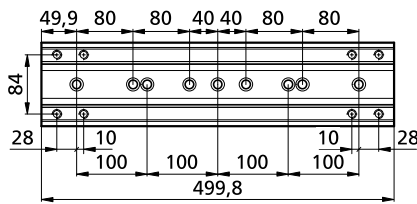

ACB4050800 kg ~35

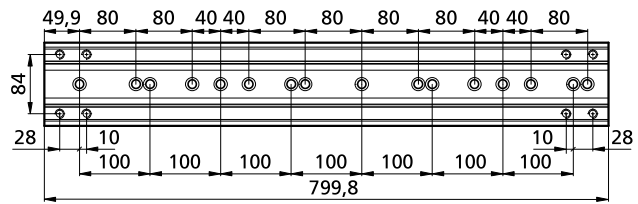

ACB4050550 kg ~24

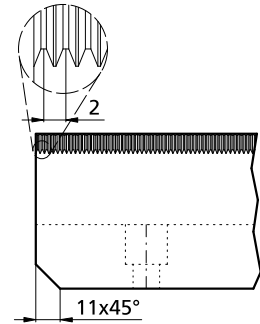
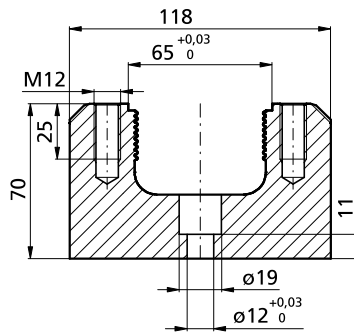
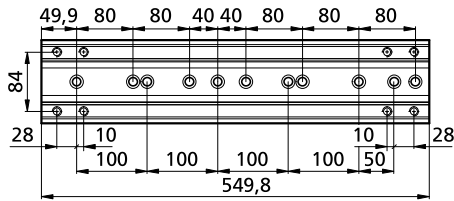

ACB4050600 kg ~26

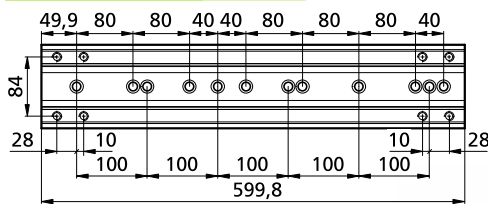

ACB4050650 kg ~29

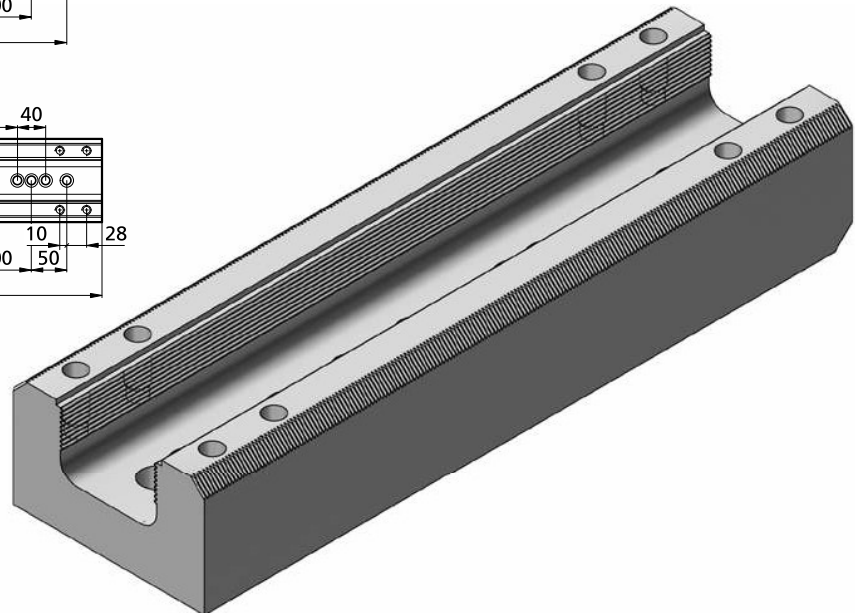
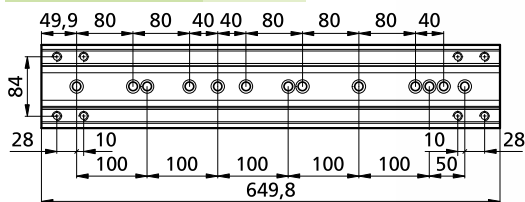



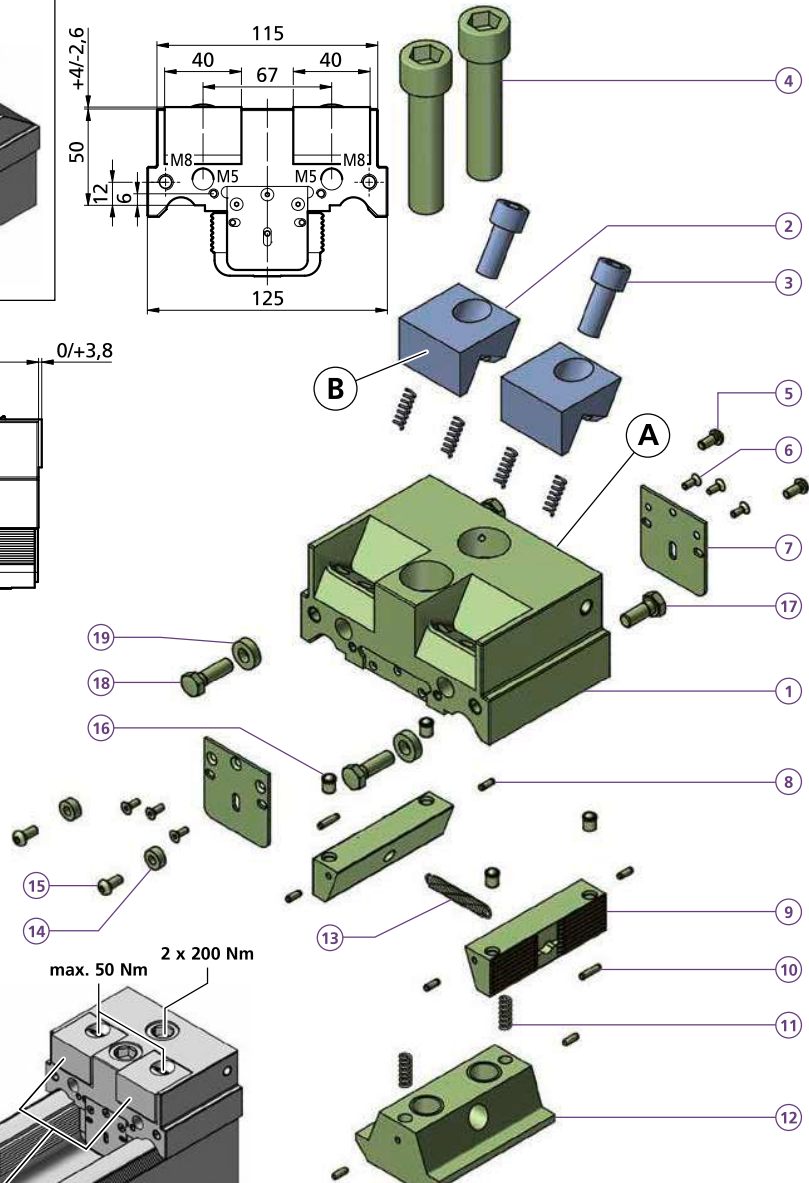
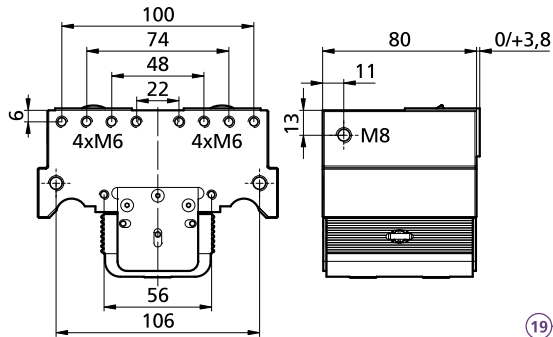
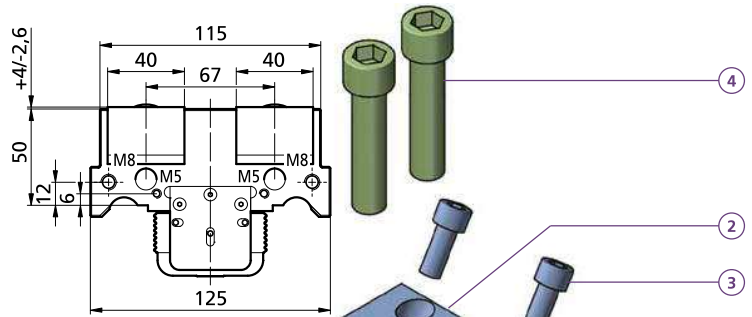
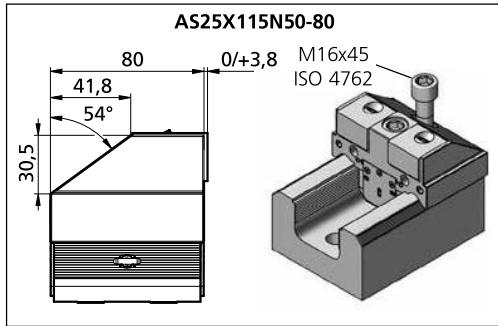

- AS25X115N50-80**
- 1 1x TF140678
  - 4 1x M16X45ISO4762
  - 1x M16X70ISO4762
  - 18 2x M8X20ISO4017
  - 19 2x ACD005
- kg ~4,3
- AS2F115N50-80**
- 1 1x TF140676
- AS2R115N50-80**
- 1 1x TF140677
  - 2 2x
  - 3 2x M10X25ISO4762
  - 4 2x M16X70ISO4762
  - 5 2x M5X10ISO7380-1
  - 6 6x M3X6DIN7991
  - 7 2x ACBL4243
  - 8 6x Ø 3x8 VSM 12785
  - 9 2x ACSP7620
  - 10 2x Ø 3h 8x12 ISO 2338
  - 11 6x FED0618
  - 12 1x ACSK7632M16
  - 13 1x FED Ø 5,5x39
  - 14 2x PCD005
  - 15 2x M5X14ISO7380-1
  - 16 4x Ø 6-Niro SM1275-3
  - 17 2x M8X16ISO4017
  - 18 2x M8X20ISO4017
  - 19 2x ACD005
- kg ~4,8

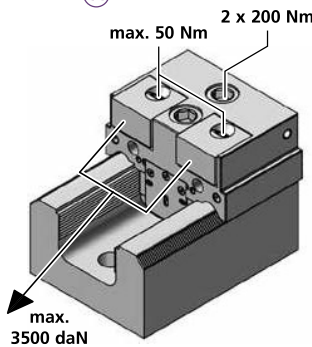

Bestellbeispiel / Ordering example: 1x AS2R115N50-80 & 2x B80

	B80	B80N	B81	B82	B82L33	B82HM	B83	B84	B89F	B89R
C	40	40	40	40	40	40	40	40	40	40
H	25	25	25	25	25	25	25	25	25	25
L	22	22	22	22,2	33	22,2	22	26,3	29	29
D	11	11	11	11	11	11	11	11	11	11
ø	15	15	15	15	15	15	15	15	15	15
I	56HRC	HV700	56HRC	*	*	56HRC	HV700	*	HV700	HV700
		x0,2mm					x0,2mm		x0,2mm	x0,2mm
kg	~0,2	~0,2	~0,2	~0,2	~0,28	~0,2	~0,2	~0,2	~0,24	~0,24

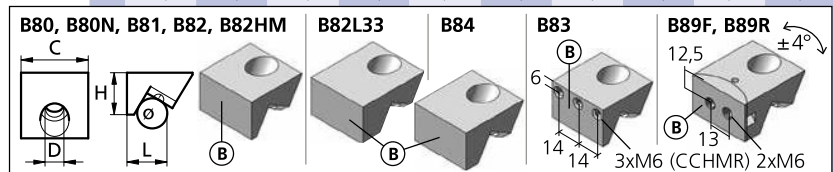

\* = weich / soft

HM = Hartmetallbeschichtet / Carbide coated

Separat bestellen / Separate order

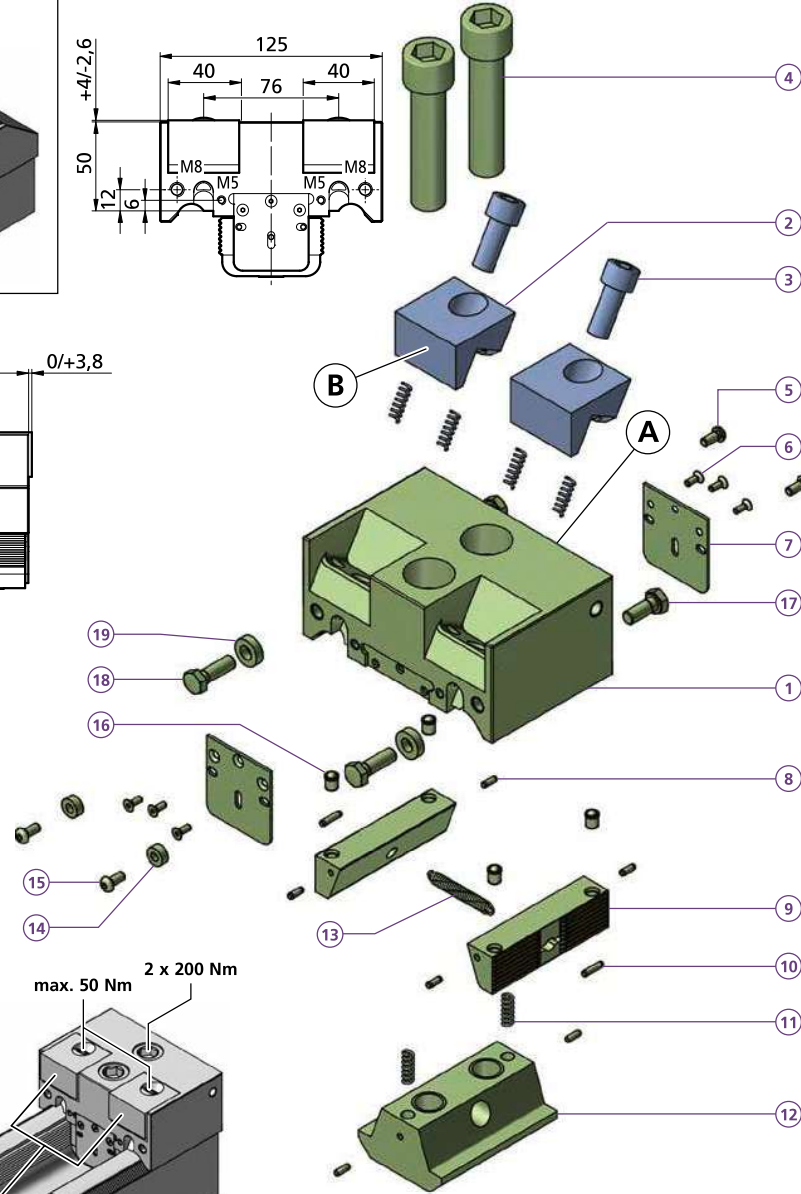
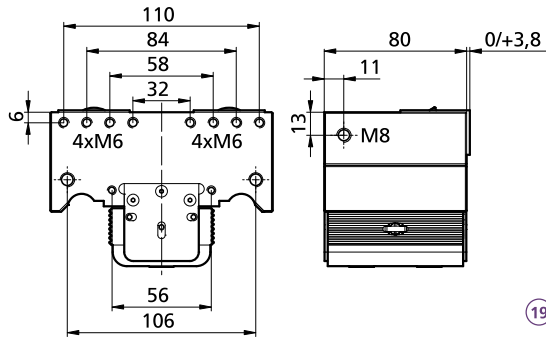
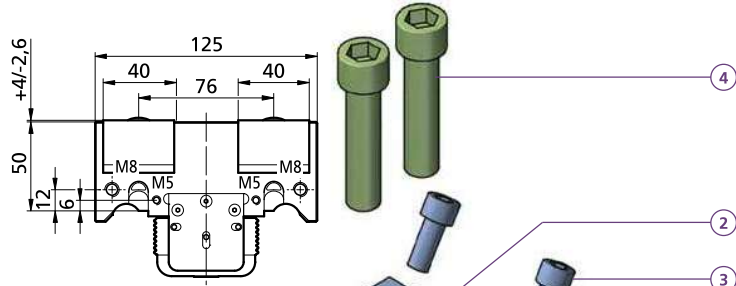
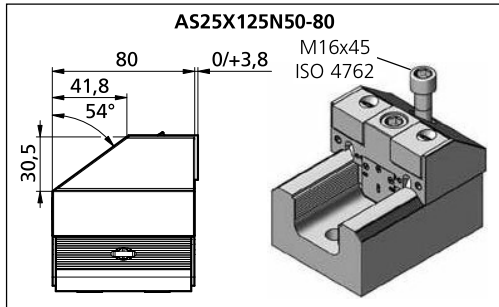

- AS25X125N50-80**
- 1 1x TF140682
  - 4 1x M16X45ISO4762
  - 1x M16X70ISO4762
  - 18 2x M8X20ISO4017
  - 19 2x ACD005
- kg ~4,3
- 
- AS2F125N50-80**
- 1 1x TF140680
- 
- AS2R125N50-80**
- 1 1x TF140681
  - 2 2x
  - 3 2x M10X25ISO4762
  - 4 2x M16X70ISO4762
  - 5 2x M5X10ISO7380-1
  - 6 6x M3X6DIN7991
  - 7 2x ACBL4243
  - 8 6x Ø 3x8 BN 879
  - 9 2x ACSP7620
  - 10 2x Ø 3h 8x12 ISO 2338
  - 11 6x FED0618
  - 12 1x ACSK7632M16
  - 13 1x FED Ø 5,5x39
  - 14 2x PCD005
  - 15 2x M5X14ISO7380-1
  - 16 4x Ø 6-Niro SM1275-3
  - 17 2x M8X16ISO4017
  - 18 2x M8X20ISO4017
  - 19 2x ACD005
- kg ~4,9

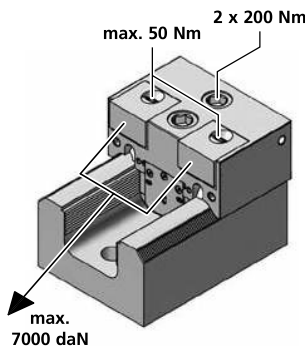

max. 7000 daN

Bestellbeispiel / Ordering example: 1x AS2R125N50-80 & 2x B80

	B80	B80N	B81	B82	B82L33	B82HM	B83	B84	B89F	B89R
C	40	40	40	40	40	40	40	40	40	40
H	25	25	25	25	25	25	25	25	25	25
L	22	22	22	22,2	33	22,2	22	26,3	29	29
D	11	11	11	11	11	11	11	11	11	11
ø	15	15	15	15	15	15	15	15	15	15
i	56HRC	HV700	56HRC	*	*	56HRC	HV700	*	HV700	HV700
		x0,2mm					x0,2mm		x0,2mm	x0,2mm
kg	~0,2	~0,2	~0,2	~0,2	~0,28	~0,2	~0,2	~0,2	~0,24	~0,24

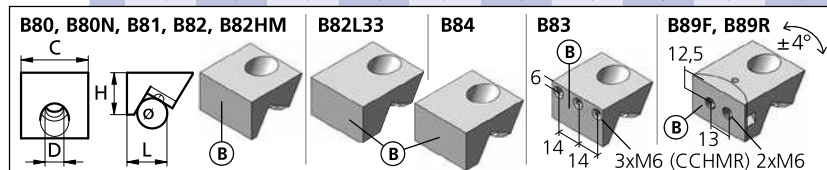

Separat bestellen / Separate order

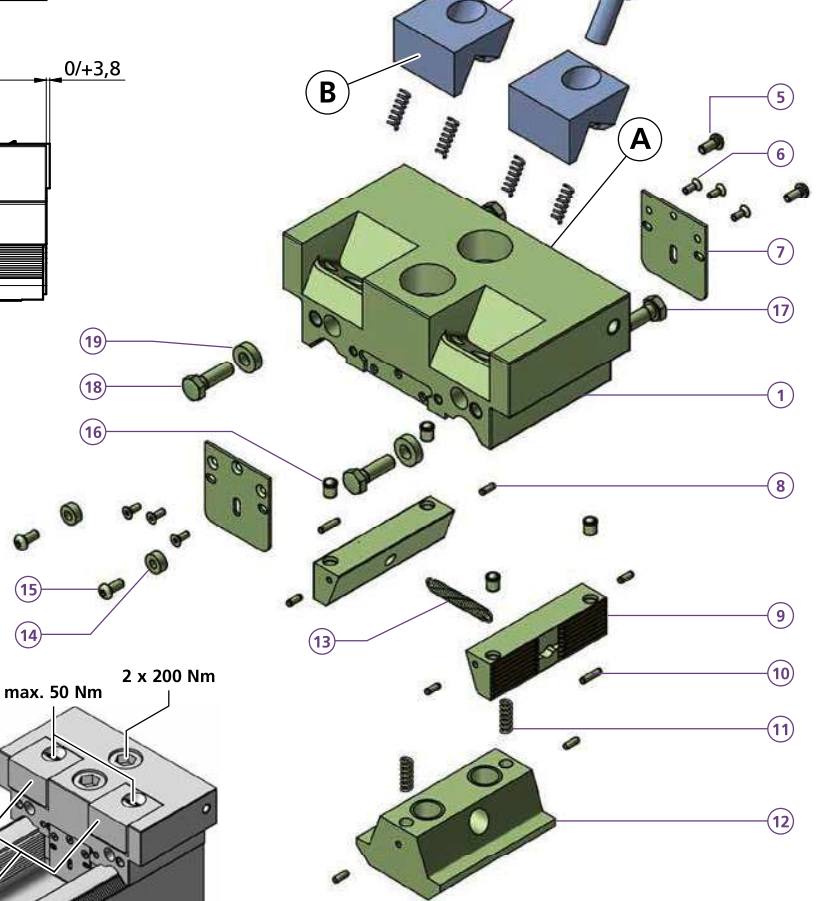
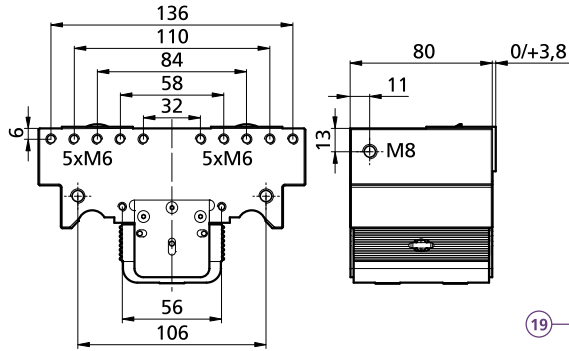
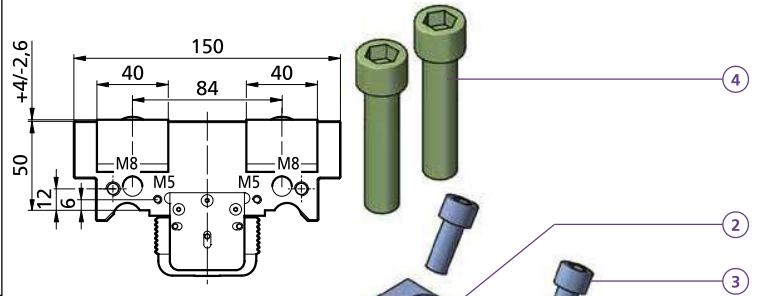
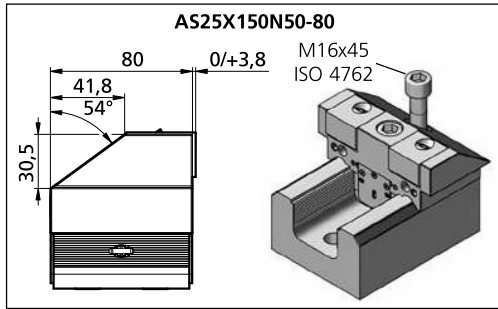

- AS25X150N50-80**
- 1 1x TF140687
  - 4 1x M16X45ISO4762
  - 1x M16X70ISO4762
  - 18 2x M8X20ISO4017
  - 19 2x ACD005
  - kg ~4,7
- AS2F150N50-80**
- 1 1x TF140685
- AS2R150N50-80**
- 1 1x TF140686
  - 2 2x
  - 3 2x M10X25ISO4762
  - 4 2x M16X70ISO4762
  - 5 2x M5X10ISO7380-1
  - 6 6x M3X6DIN7991
  - 7 2x ACBL4243
  - 8 6x Ø 3x8 VSM 12785
  - 9 2x ACSP7620
  - 10 2x Ø 3h 8x12 ISO 2338
  - 11 6x FED0618
  - 12 1x ACSK7632M16
  - 13 1x FED Ø 5,5x39
  - 14 2x PCD005
  - 15 2x M5X14ISO7380-1
  - 16 4x Ø 6-Niro SM1275-3
  - 17 2x M8X16ISO4017
  - 18 2x M8X20ISO4017
  - 19 2x ACD005
  - kg ~5,4

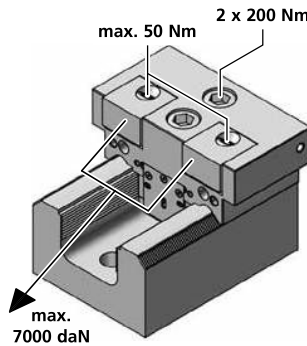

Bestellbeispiel / Ordering example: 1x AS2R150N50-80 & 2x B80

	B80	B80N	B81	B82	B82L33	B82HM	B83	B84	B89F	B89R
C	40	40	40	40	40	40	40	40	40	40
H	25	25	25	25	25	25	25	25	25	25
L	22	22	22	22,2	33	22,2	22	26,3	29	29
D	11	11	11	11	11	11	11	11	11	11
ø	15	15	15	15	15	15	15	15	15	15
i	56HRC	HV700	56HRC	*	*	56HRC	HV700	*	HV700	HV700
kg	~0,2	~0,2	~0,2	~0,2	~0,28	~0,2	~0,2	~0,2	~0,24	~0,24

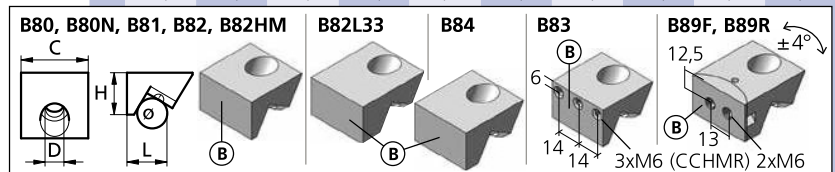

\* = weich / soft

HM = Hartmetallbeschichtet / Carbide coated

Separat bestellen / Separate order

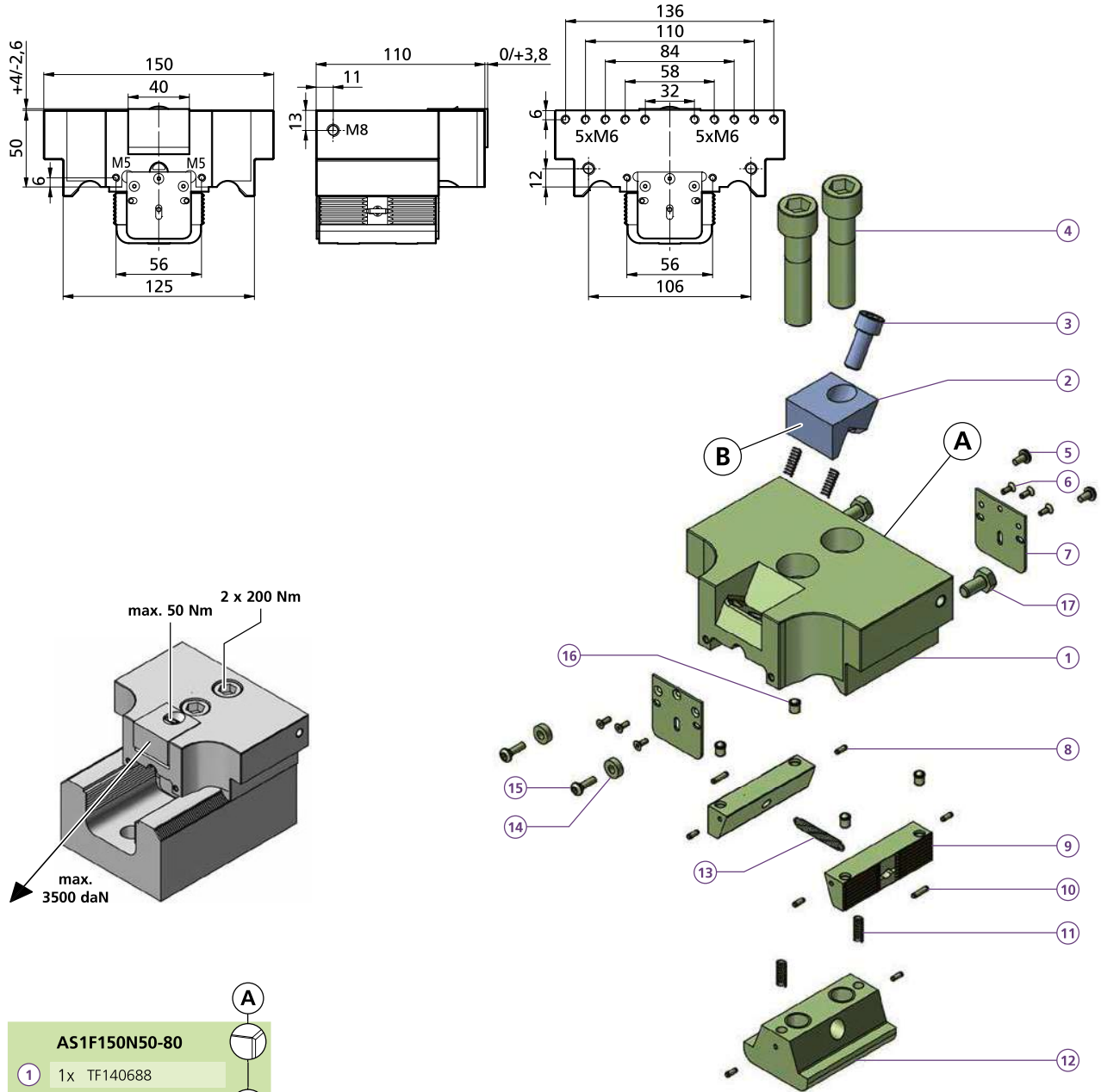

<b>AS1F150N50-80</b>	
1x TF140688	
<b>AS1R150N50-80</b>	
1x TF140689	
2x	
1x M10X25ISO4762	
2x M16X70ISO4762	
2x M5X10ISO7380-1	
6x M3X6DIN7991	
2x ACBL4243	
6x Ø 3x8 VSM 12785	
2x ACSF7620	
2x Ø 3h 8x12 ISO 2338	
4x FED0618	
1x ACSK7632M16	
1x FED Ø 5,5x39	
2x PCD005	
2x M5X14ISO7380-1	
4x Ø 6-Niro SM1275-3	
2x M8X16ISO4017	
kg ~6,6	

Bestellbeispiel / Ordering example: 1x AS1R150N50-80 & 1x B80

	B80	B80N	B81	B82	B82L33	B82HM	B83	B84	B89F	B89R
<b>C</b>	40	40	40	40	40	40	40	40	40	40
<b>H</b>	25	25	25	25	25	25	25	25	25	25
<b>L</b>	22	22	22	22,2	33	22,2	22	26,3	29	29
<b>D</b>	11	11	11	11	11	11	11	11	11	11
<b>ø</b>	15	15	15	15	15	15	15	15	15	15
<b>i</b>	56HRC	HV700	56HRC	*	*	56HRC	HV700	*	HV700	HV700
<b>kg</b>	~0,2	~0,2	~0,2	~0,2	~0,28	~0,2	~0,2	~0,2	~0,24	~0,24

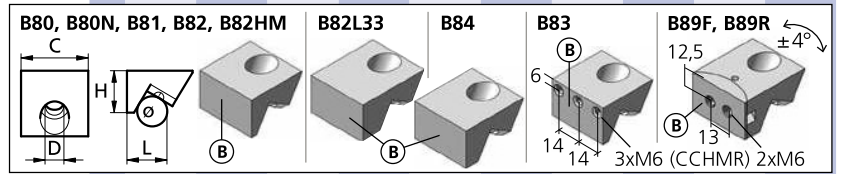

**AS2X125L50-105**  
**AS25X125L50-105**

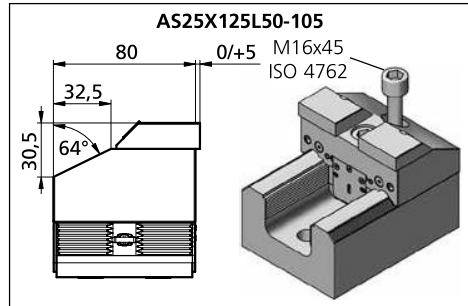
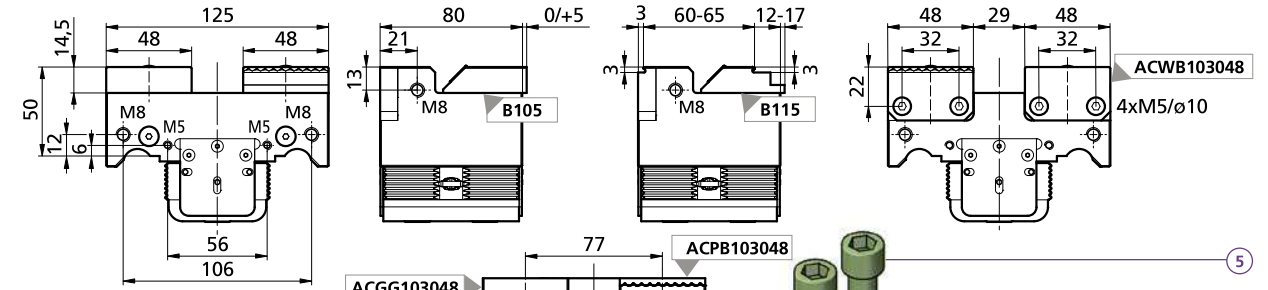

- |   |                            |
|---|----------------------------|
|  | <b>AS25X125L50-105</b>     |
| 1   | 1x TF140683                |
| 4   | 1x M16X45ISO4762           |
| 4   | 1x M16X55ISO4762           |
| 19  | 2x M8X20ISO4017            |
| 20  | 2x ACD005                  |
| kg  | ~4,3                       |
|   | <b>AS2X125L50-105</b>      |
| 1   | 1x TF140684                |
| 2   | 2x <b>powerCLAMP</b> p. 85 |
| 3   | 2x M8X30ISO4762            |
| 4   | 2x PCUSR 14                |
| 5   | 2x M16X55ISO4762           |
| 6   | 2x M5X10ISO7380-1          |
| 7   | 6x M3X6DIN7991             |
| 8   | 2x ACBL4243                |
| 9   | 6x Ø 3x8 VSM 12785         |
| 10  | 2x ACSP7620                |
| 11  | 2x Ø 3h 8x12 ISO 2338      |
| 12  | 6x FED0618                 |
| 13  | 1x ACSK7632M16             |
| 14  | 1x FED Ø 5,5x39            |
| 15  | 2x PCD005                  |
| 16  | 2x M5X14ISO7380-1          |
| 17  | 4x Ø 6-Niro SM1275-3       |
| 18  | 2x M8X16ISO4017            |
| 19  | 2x M8X20ISO4017            |
| 20  | 2x ACD005                  |
| 21  | 2x                         |
| 22  | 4x M5X20ISO7380-1          |
| 23  | 4x Ø 5,2 ISO 4247          |
| 24  | 2x M5x10 DIN 7991          |
| 25  | 2x PCKMR45M8               |
| 26  | 4x d=6 DIN 5401            |
| 27  | 2x TS120001                |
| kg  | ~4,5                       |

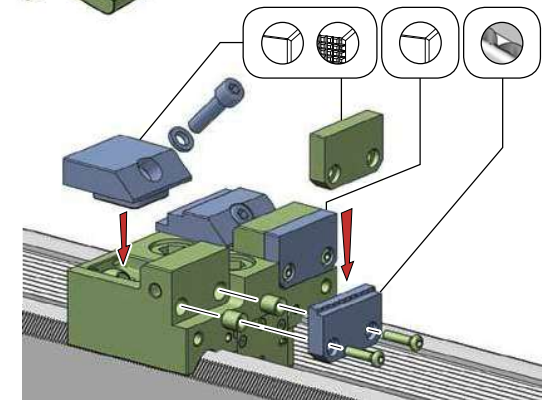
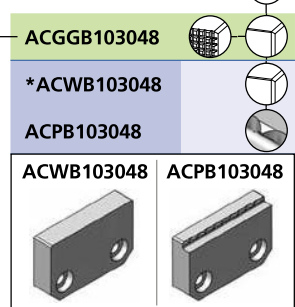
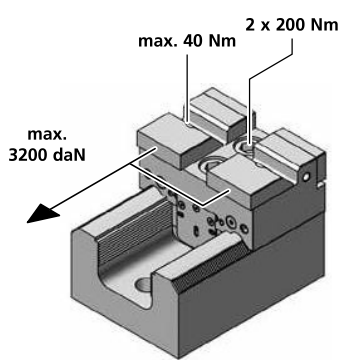
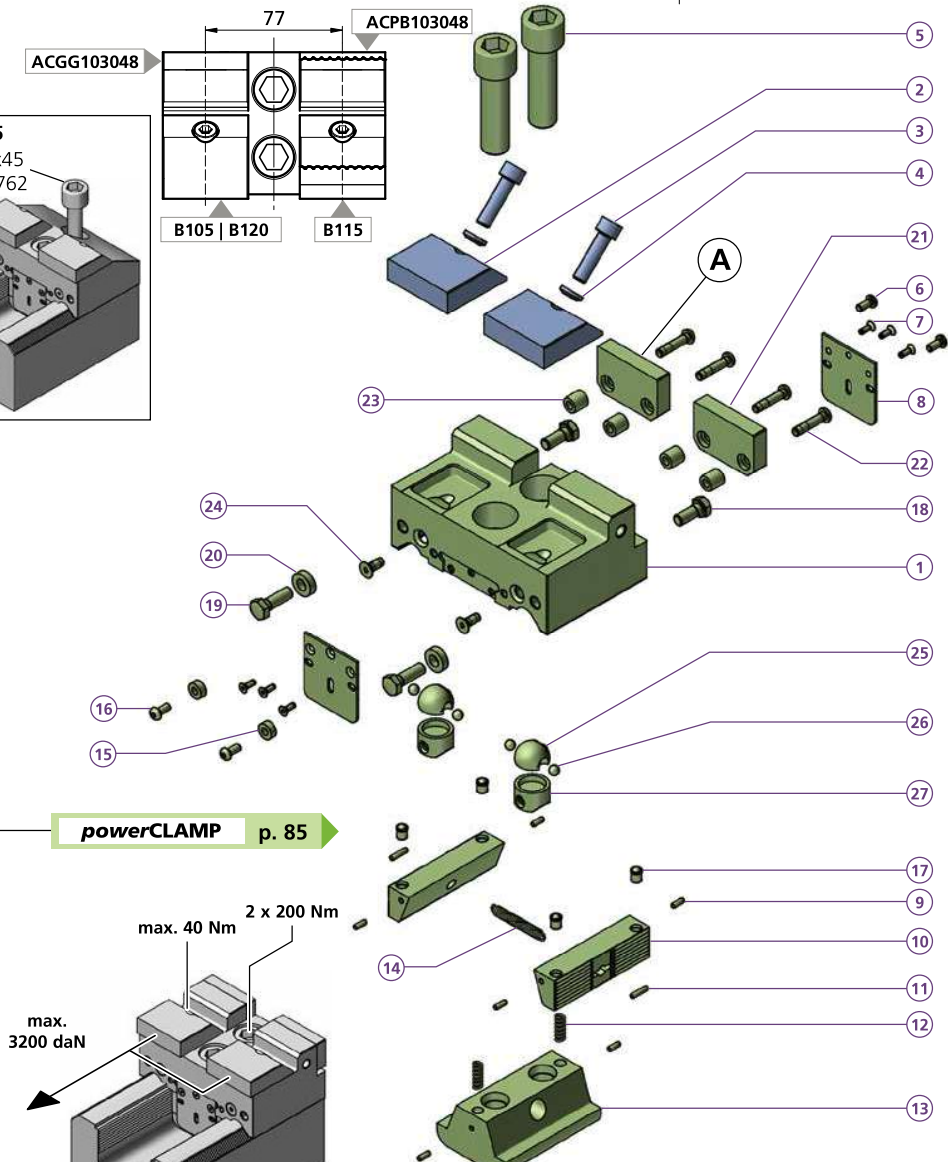

**Bestellbeispiel / Ordering example:**  
1x AS2X125L50-150 & 2x B105 & 2x ACGGB103048

Separat bestellen / Separate order

\* = weich / soft

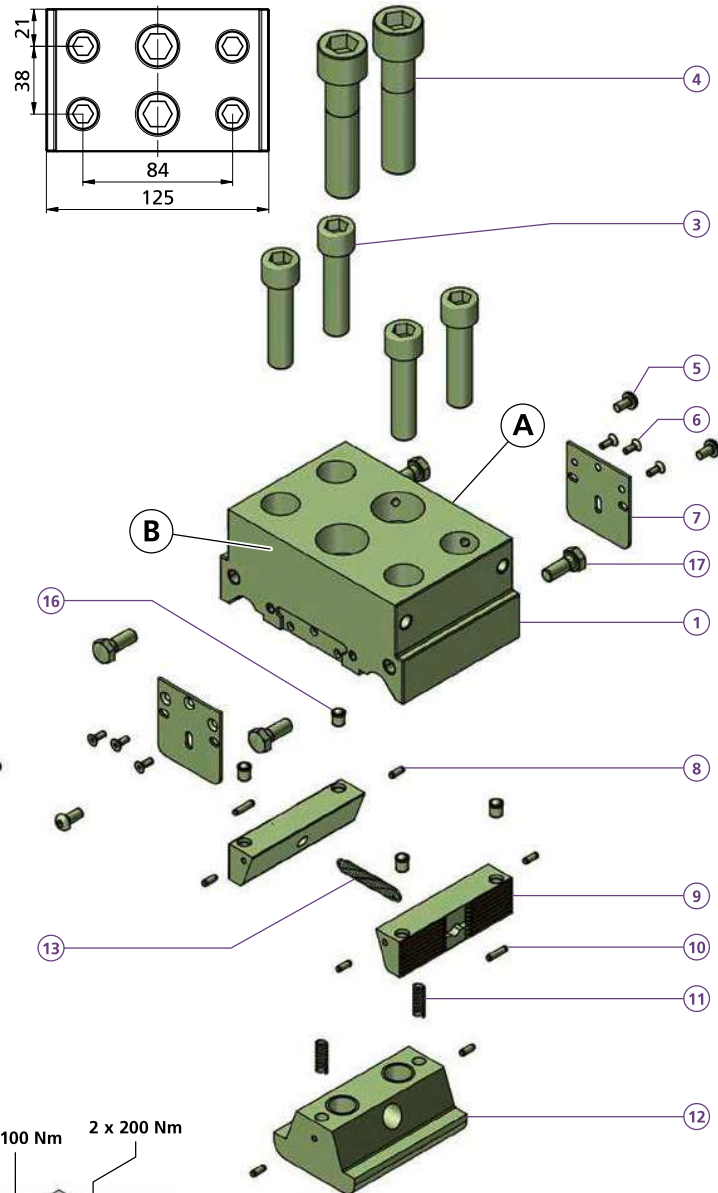
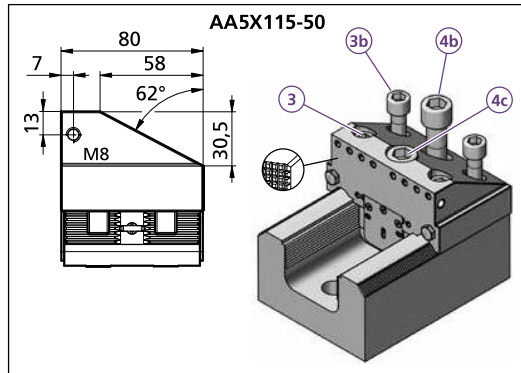
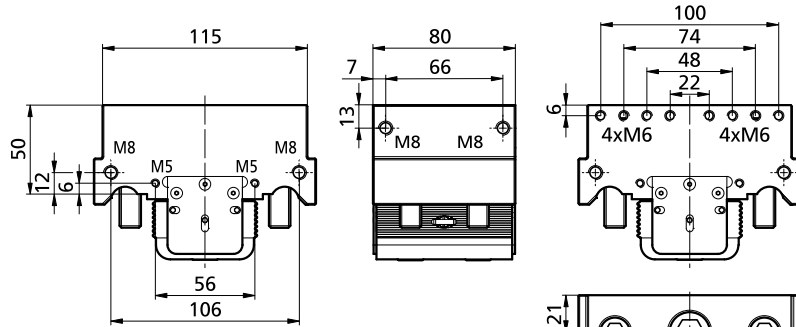

AAND115-50	
1	1x TF140690
3	4x M12X50ISO4762
4	2x M16X70ISO4762
5	4x M5X10ISO7380-1
6	6x M3X6DIN7991
7	2x ACBL4243
8	6x Ø 3x8 VSM 12785
9	2x ACS P7620
10	2x Ø 3h 8x12 ISO 2338
11	2x FED0618
12	1x ACSK7632M16
13	1x FED Ø 5,5x39
16	4x Ø 6-Niro SM1275-3
17	4x M8X16ISO4017
kg	~4,7

AA5X115-50	
1	1x TF140691
3	2x M12X50ISO4762
3b	2x M12X30ISO4762
4c	1x M16X65ISO4762
4b	1x M16X45ISO4762
5	2x M5X10ISO7380-1
17	2x M8X16ISO4017
kg	~4,6

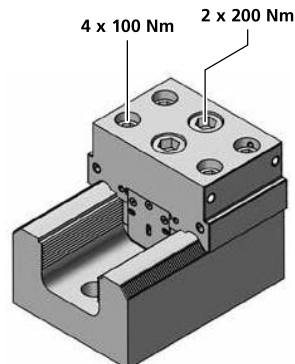

# AAND125-50

## AA5X125-50



aptoCLAMP

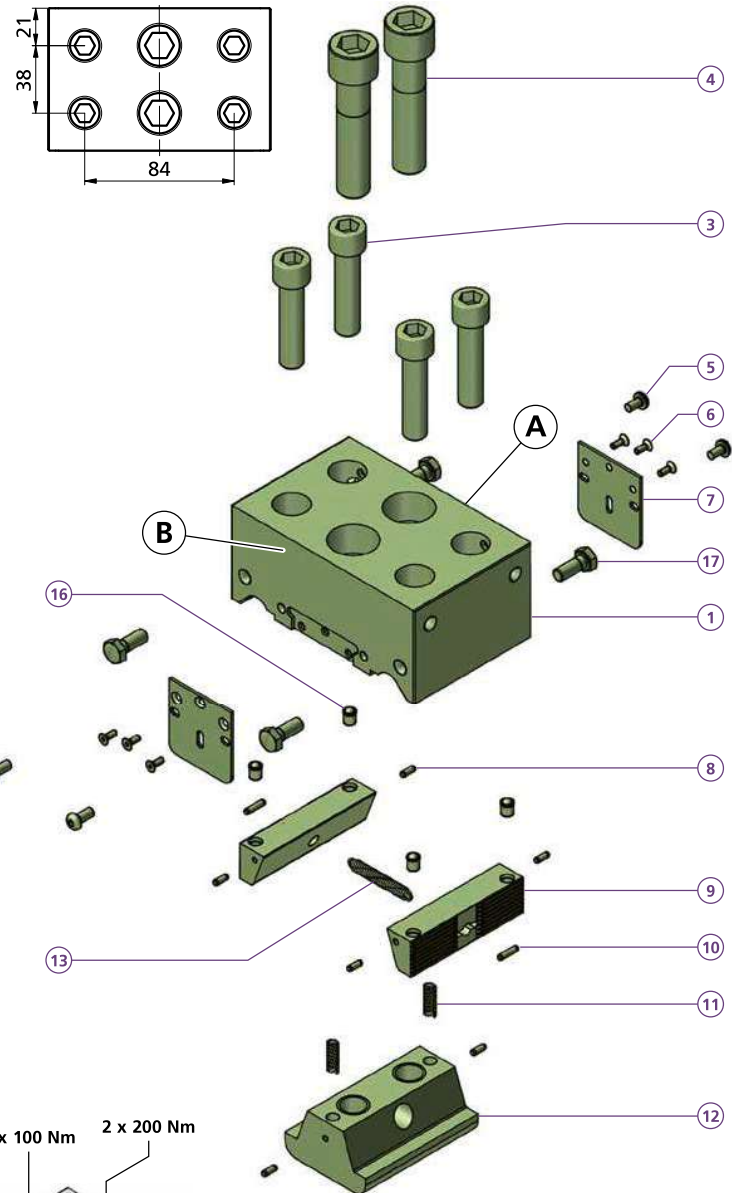
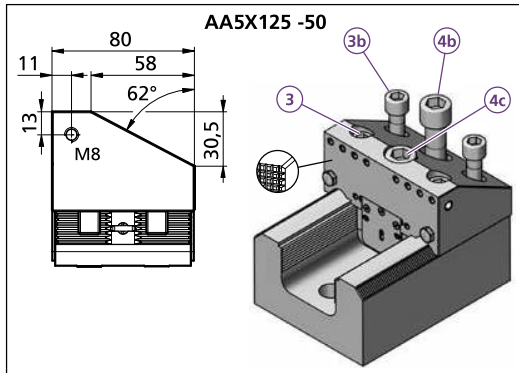
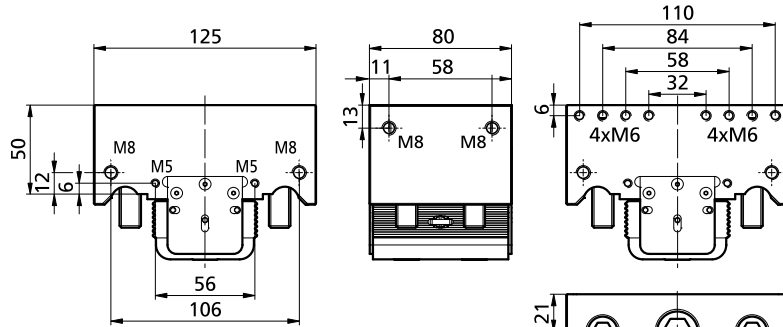

AAND125-50	
1	1x TF140692
3	4x M12X50ISO4762
4	2x M16X70ISO4762
5	4x M5X10ISO7380-1
6	6x M3X6DIN7991
7	2x ACBL4243
8	6x Ø 3x8 VSM 12785
9	2x ACSP7620
10	2x Ø 3h 8x12 ISO 2338
11	2x FED0618
12	1x ACSK7632M16
13	1x FED Ø 5,5x39
16	4x Ø 6-Niro SM1275-3
17	4x M8X16ISO4017
kg	~4,8

AA5X125-50	
1	1x TF140693
3	2x M12X50ISO4762
3b	2x M12X30ISO4762
4c	1x M16X65ISO4762
4b	1x M16X45ISO4762
5	2x M5X10ISO7380-1
17	2x M8X16ISO4017
kg	~4,6

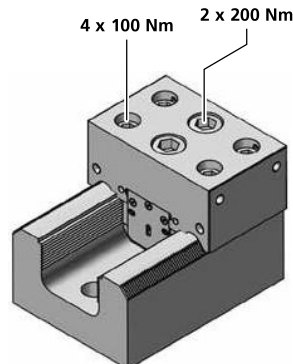

Bestellbeispiel / Ordering example: AAND125-50

# AAND150-50

## AA5X150-50



aptoCLAMP

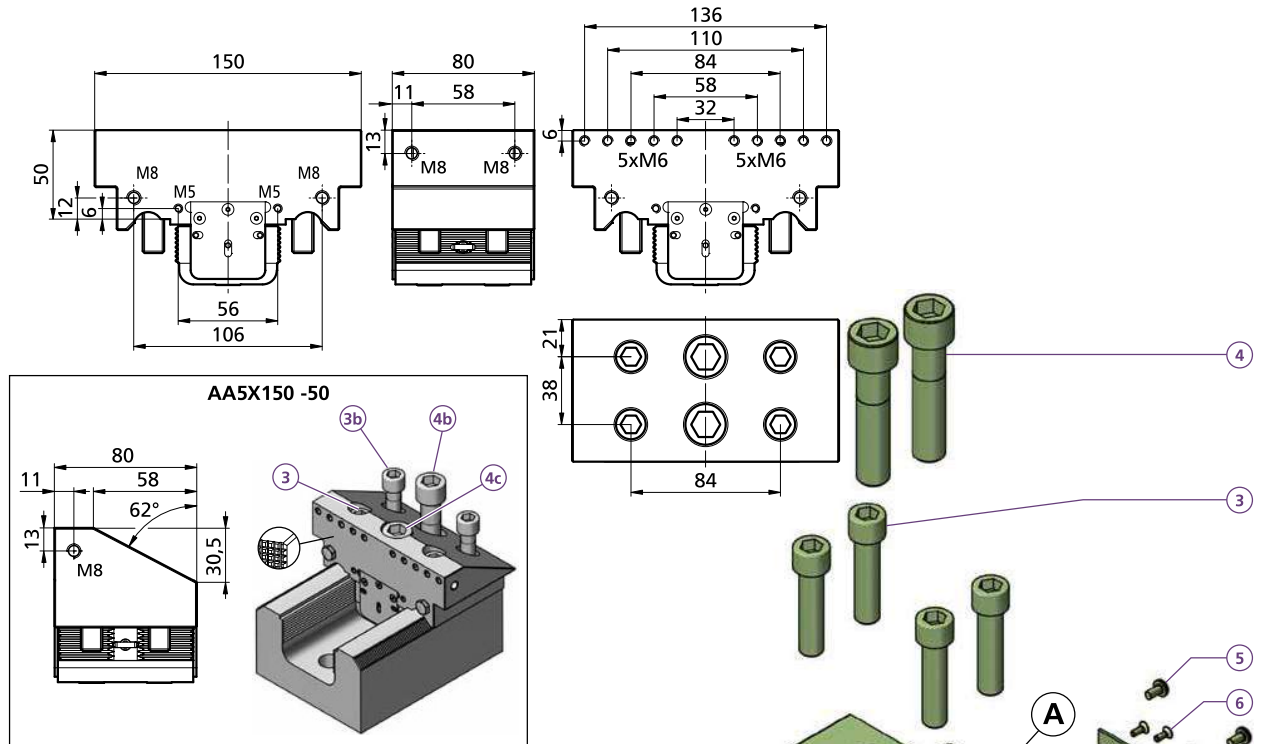

- AAND150-50**
- 1 1x TF140695
  - 3 4x M12X50ISO4762
  - 4 2x M16X70ISO4762
  - 5 4x M5X10ISO7380-1
  - 6 6x M3X6DIN7991
  - 7 2x ACBL4243
  - 8 6x Ø 3x8 VSM 12785
  - 9 2x ACSP7620
  - 10 2x Ø 3h 8x12 ISO 2338
  - 11 2x FED0618
  - 12 1x ACSK7632M16
  - 13 1x FED Ø 5,5x39
  - 16 4x Ø 6-Niro SM1275-3
  - 17 4x M8X16ISO4017
- kg ~5,2

- AA5X150-50**
- 1 1x TF140696
  - 3 2x M12X50ISO4762
  - 3b 2x M12X30ISO4762
  - 4c 1x M16X65ISO4762
  - 4b 1x M16X45ISO4762
  - 5 2x M5X10ISO7380-1
  - 17 2x M8X16ISO4017
- kg ~5,0

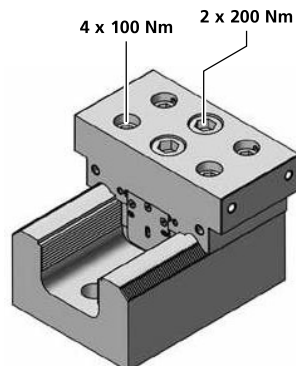

Bestellbeispiel / Ordering example: **AAND150-50**





# AA5X125-50VB

aptoCLAMP

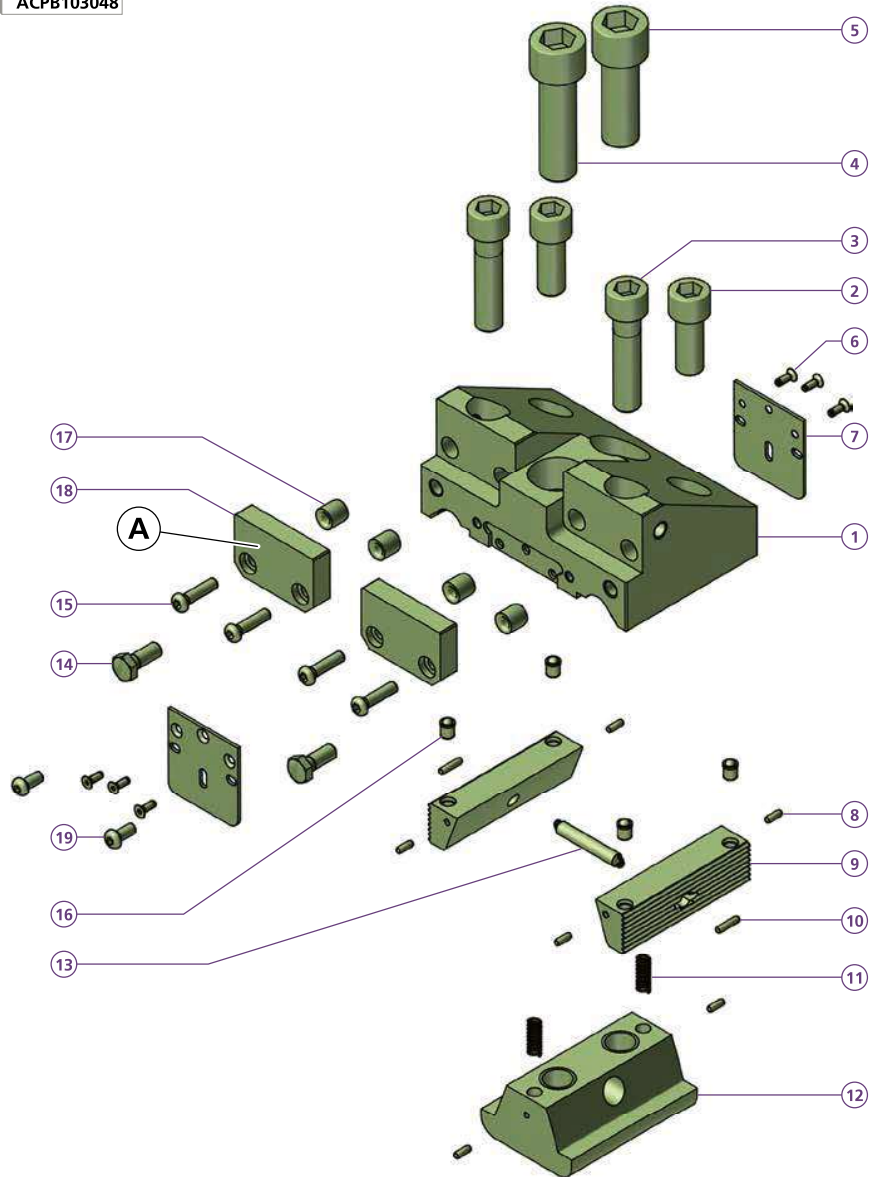
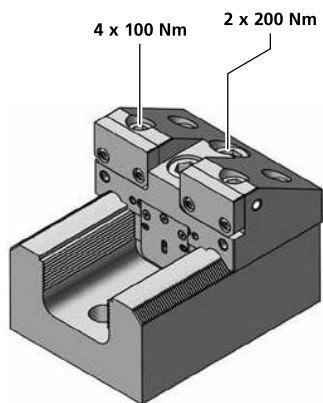
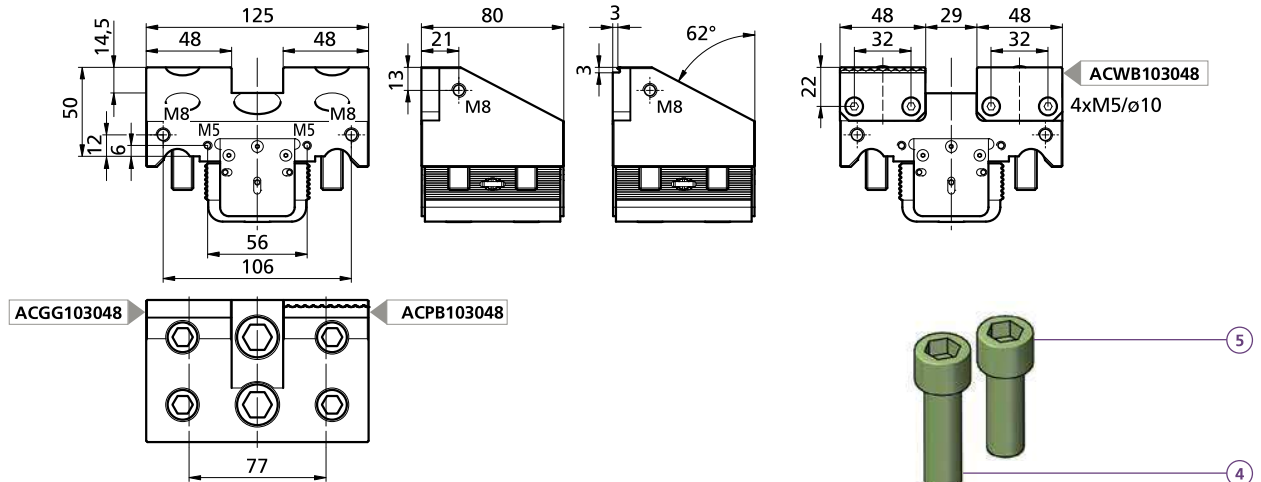

AA5X125-50VB	
1	1x TF140694
2	2x M12X30ISO4762
3	2x M12X50ISO4762
4	1x M16X55ISO4762
5	1x M16X45ISO4762
6	6x M3X6DIN7991
7	2x ACBL4243
8	6x Ø 3x8 VSM 12785
9	2x ACSP7620
10	2x Ø 3h 8x12 ISO 2338
11	2x FED0618
12	1x ACSK7632M16
13	1x FED Ø 5,5x39
14	2x M8X16ISO4017
15	4x M5X20ISO4762
16	4x Ø 6-Niro SM1275-3
17	4x 5,2x10x10 DIN179-A
18	2x _____
19	2x M5X10ISO7380-1
kg	~4,5

ACGGB103048	
*ACWB103048	
ACPB103048	
ACWB103048	
ACPB103048	

Bestellbeispiel / Ordering example:  
 1x AA5X125-50VB & 2x ACGGB103048

Separat bestellen / Separate order

\* = weich / soft



**Parallelunterlage  
Steel parallels**

124mm	B	H	kg
ACU21124	124	21	~0,138
ACU36124	124	36	~0,250
ACU41124	124	41	~0,294
ACU46124	124	46	~0,328

94mm	B	H	kg
PCU14093	93	14	~0,04
PCU20093	93	20	~0,06
PCU24093	93	24	~0,07
PCU29093	93	29	~0,09
PCU31093	93	31	~0,09
PCU34093	93	34	~0,10
PCU39093	93	39	~0,11
PCU44093	93	44	~0,12
PCU46093	93	46	~0,14

125mm	B	H	kg
PCU20124	124	20	~0,08
PCU24124	124	24	~0,09
PCU29124	124	29	~0,11
PCU31124	124	31	~0,12
PCU34124	124	34	~0,13
PCU39124	124	39	~0,15
PCU44124	124	44	~0,17

**Universalnutenstein  
Universal nut**

**ACES6540**

- ① 1x ACZS6540
- ② 1x ACEL6540
- ③ 1x M12X30DIN7984
- ④ 2x SM1275-1KSM8

kg ~ 0,67



**ACES10240H07**

- ① 1x ACZS6540
- ② 1x ACEL6540-07102
- ③ 1x M12X30DIN7984
- ④ 2x SM1275-1KSM8

kg ~ 0,88



**ACES10040H25W**

- ① 1x ACZS6540
- ② 1x ACEL10040H25W
- ③ 1x M12X30DIN7984
- ④ 2x SM1275-1KSM8

kg ~ 1,42

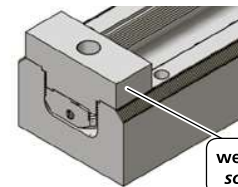

weich  
soft 1.2312

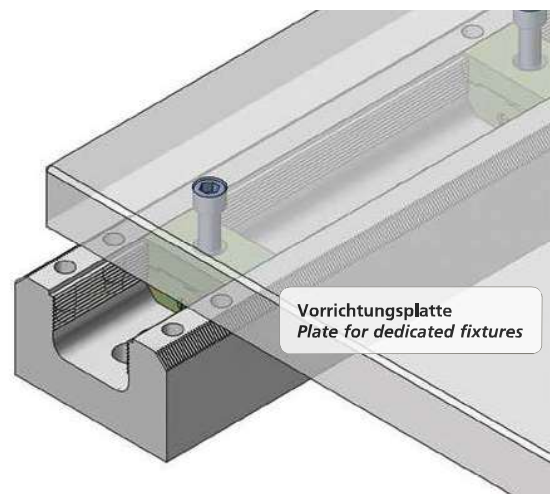

Bestellbeispiel / Ordering example: **ACES6540**

Separat bestellen / Separate order

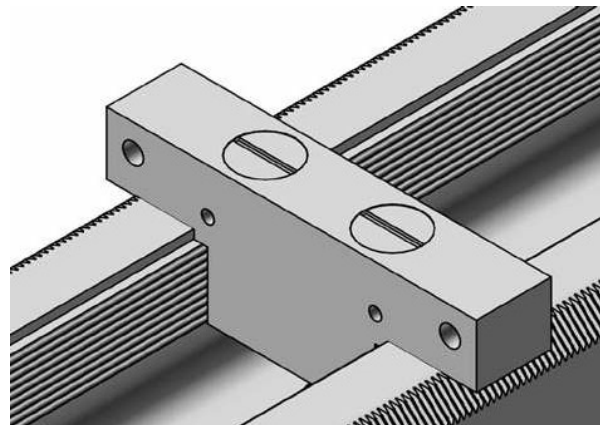
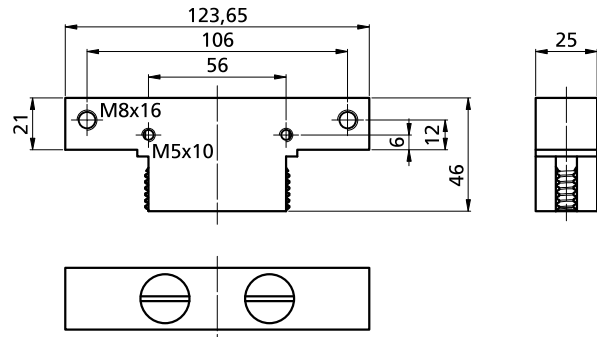
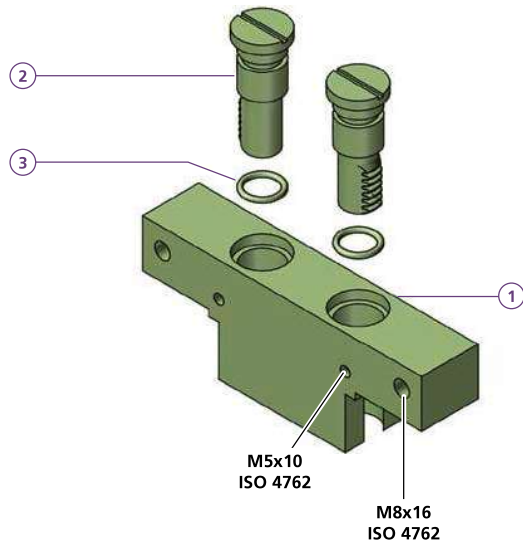

Bestellbeispiel / Ordering example: ACUH21-124

<b>ACUH21-124</b>	
①	1x TW090086-02
②	2x ACBS1646
③	2x OR Ø 12X2
kg	~ 0,74

**weiche Backe**  
**soft jaw**

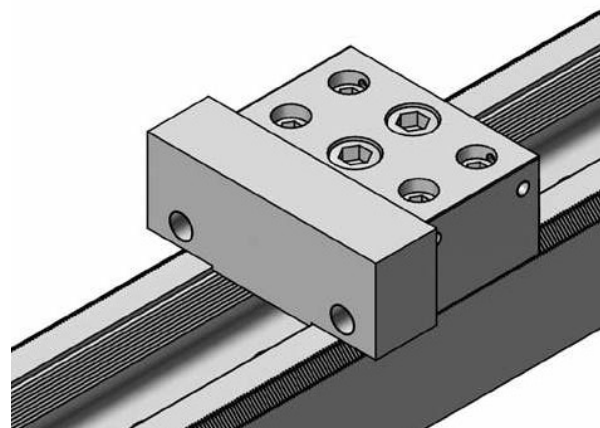
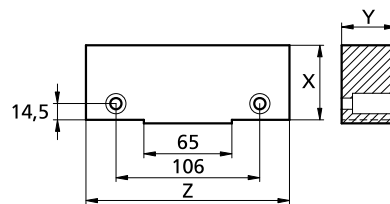
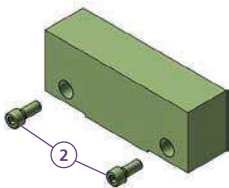

Bestellbeispiel / Ordering example: AC1505520W

		X	Y	Z	kg
AC1505520W	②	55	20	150	~ 1,28
AC1505540W	M8X20ISO4762	55	40	150	~ 2,55

<b>Kunde</b> <i>Customer</i>			
<b>Maschine</b> <i>Machine</i>		Werkstoff, Halbzeug, Rohteil-Nr., Modell- oder Gesenk-Nr. <i>Raw material, blank or casting-Nr.</i>	
<b>X</b>	Verfahrweg <i>Traverse</i>		<b>mm</b>
<b>Y</b>	Verfahrweg <i>Traverse</i>		<b>mm</b>
<b>Z</b>	Verfahrweg <i>Traverse</i>		<b>mm</b>
<b>Z min.</b>	kleinster Abstand von der Tischoberfläche zur Spindelnahe <i>smallest distance from table surface to spindle gauge line</i>		<b>mm</b>
<b>Z max.</b>	grösster Abstand von der Tischoberfläche zur Spindelnahe <i>greatest distance from table surface to spindle gauge line</i>		<b>mm</b>
<b>∅ Spindel</b> <i>Spindle</i>	Spindeldurchmesser <i>Spindle diameter</i>		<b>mm</b>
<b>kg max.</b>	Maximale Tischbelastung <i>Maximum loading capacity</i>		<b>kg</b>
<b>A x B</b>	Tischgrösse <i>Size of the table</i>		<b>mm</b>
<b>E</b>	T-Nuten Grösse <i>T-slots size</i>		<b>mm</b>
<b>C</b>	T-Nuten Abstand <i>T-slots distance</i>		<b>mm</b>
<b>Rasterplatte</b> <i>Grid plate</i>	<b>H</b> Raster Abstand <i>Grid distance</i>	<input type="text"/> <b>mm</b>	<b>G</b> Gewinde & Passungsdurchmesser <i>Thread &amp; Precision Bohre</i> ∅
	Anzahl Werkstücke pro Los <i>Number of workpieces per lot</i>		<b>Stück</b> <i>Pieces</i>

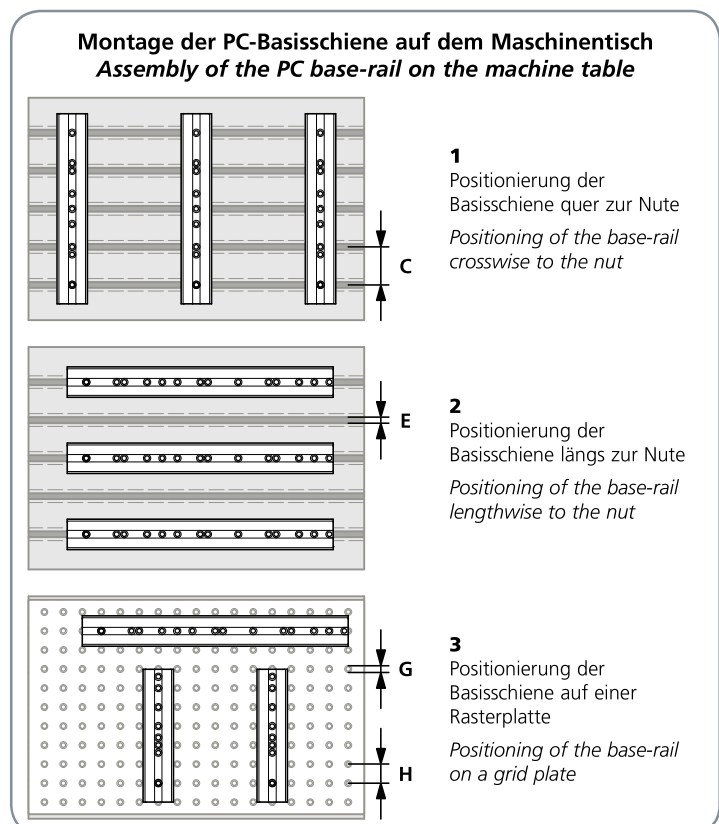
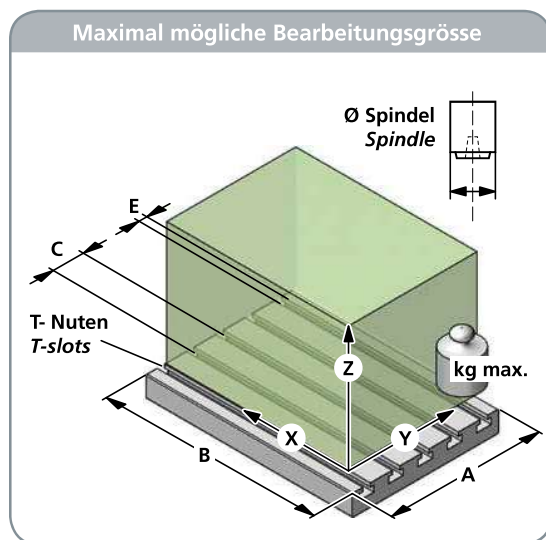

Bitte Werkstückzeichnung beilegen und Bearbeitungsfolge markieren  
*Enclose drawing of workpiece and mark processing sequence, please*