



Selection Guide for CNC Rotary Tables ...



Bluetooth®

pl

DOOSAN

06/2020 | EN



... for DNM, DT, DVM, Mynx, NX,
T, VC and VM series

CNC rotary tables for economical manufacturing:
pL LEHMANN has suitable and rational solutions for
nearly every industry

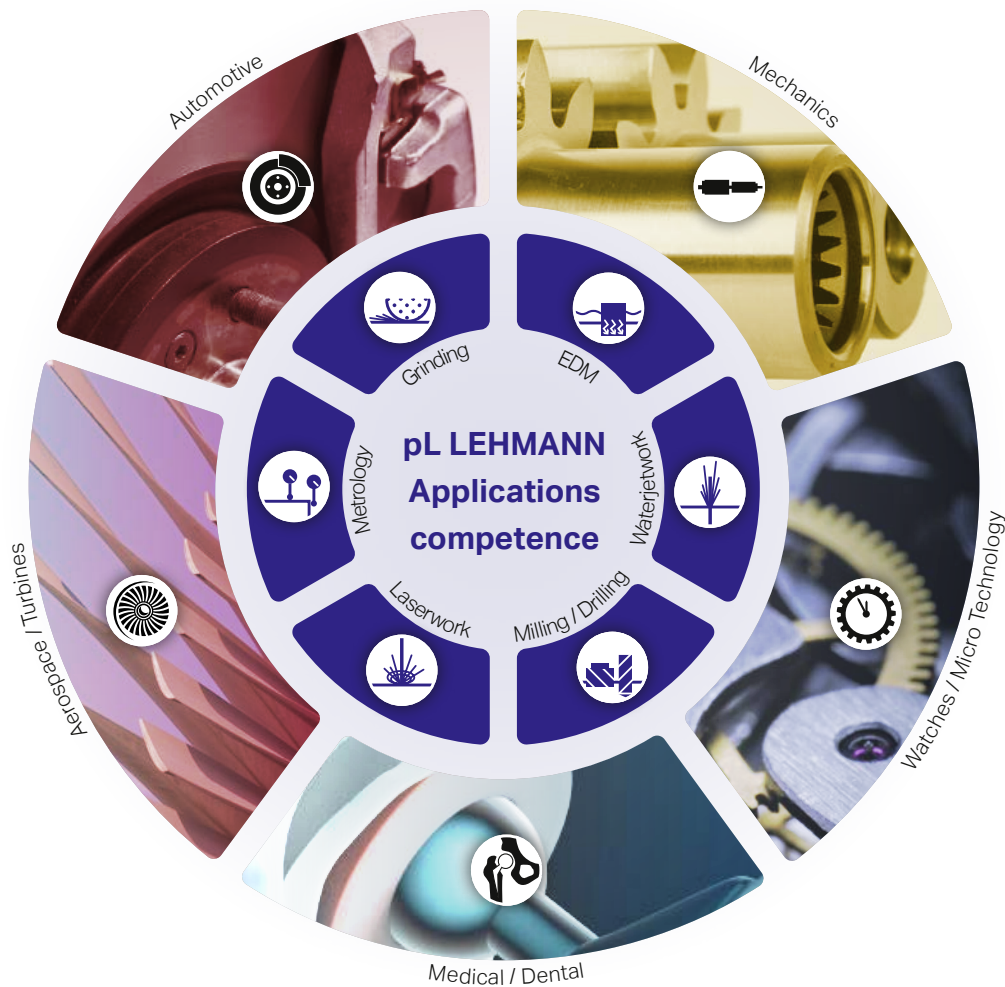

pL rotary tables in use: on over **40** different machine brands
and over **160** different machine models.

pL competence: Integration in **all known** CNC control systems
(Fanuc, Siemens, Heidenhain, Haas, Winmax, Mitsubishi, Brother,
Mazatrol, Okuma ...), for new machines as well as for retrofits

Professional products from professional partners:
DOOSAN and pL LEHMANN provide
first-class service to common customers

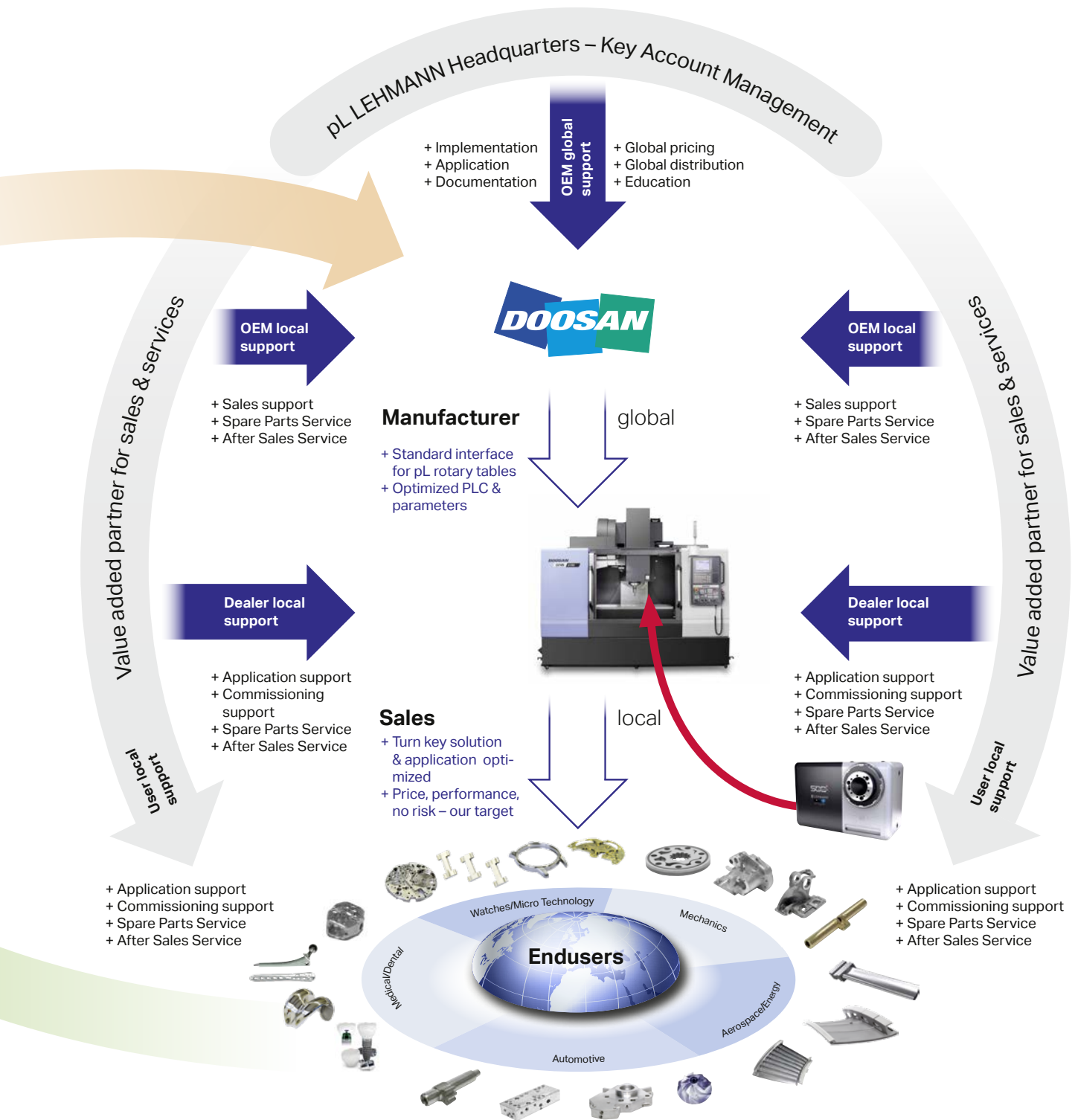

Up to 210 rpm
up to 0.21 sec / 90°

High speed GD

Extended travel in
Z- and X-direction

More space

High spindle load,
heavy-duty bearing

Heavy duty

E-Series



EA-50x light only 12 kg



DD Series NEW

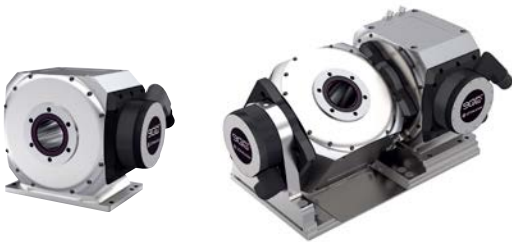

Request our
special catalog

High speed DD

up to 5'450 rpm

Adaptability

Multifunctional
spindle HSK

Precision

On the workpiece, as
precise as 2 μ m / 100 mm

Pneum. clamping
up to 7,000 Nm

High clamp

Large parts
up to \varnothing 500

Big size

PGD backlash-free
long-life gear unit

No backlash

T-Series



**All base plates
made of steel**

with integrated hole pattern for
slot spacing of 100 and 125 mm,
integrated alignment system
lineFIX for lengthwise or cross-
wise clamping.

M-Series



Connectivity

Wireless monitoring,
for operation & service

No adjust

Load change without
parameter adjustment

Less cost

No cooling system,
no hydraulics



DNM 5700



DVM 650 II

A word from DOOSAN:

«What Doosan Machine Tools makes becomes the world standard

We will enhance our efforts to develop products with growth potential for our client industries and come up with solutions and response systems to the needs of our client industries. We will lay the groundwork for continuous corporate growth through the promotion of growth strategies tailored for each region around the globe, the enhancement of our competency to respond to our global customers' needs, and the upgrade of our internal capabilities to make continuous improvements in quality and customer service.»



Mynx 5400



NX 5500 II



T 4000



VC 430



VM 5400

The right machine/rotary table combination for economical production: this Selection Guide helps you make the right selection

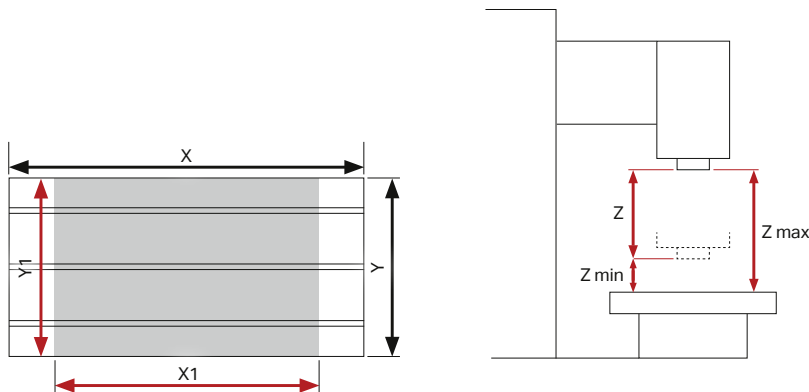

	Table diameter [mm]		Permissible overhang *	Traverse stroke [mm]					Table load ** max [kg]
	X	Y		X1	Y1	Z	Zmin	Zmax	
DNM 4000	650	400	10%	520	400	480	150	630	400
DNM 4500	1'000	450	10%	800	450	510	150	660	600
DNM 500HS	1'200	540	10%	1'020	540	510	150	660	1'000
DNM 5700	1'300	570	10%	1'050	570	510	150	660	1'000
DNM 650HS	1'300	670	10%	1'270	670	625	150	775	1'300
DNM 6700	1'500	670	10%	1'300	670	625	150	775	1'300
DNM 750 II	1'630	760	10%	1'630	762	650	150	800	1'500
DNM 400a	790	435	10%	635	435	510	150	660	400
DNM 400HS	920	435	10%	762	435	510	150	660	400
DT 360D	600	375	40%	520	360	350	150	500	200
DVM 500 II	1'200	540	10%	1'020	540	510	150	660	800
DVM 650 II	1'300	670	10%	1'270	670	625	150	775	100
Mynx 5400	1'200	540	10%	1'020	540	530	150	680	800
Mynx 6500	1'400	670	10%	1'270	670	625	150	775	1'000
Mynx 7500	1'600	750	10%	1'525	762	625	150	775	1'500
NX 5500 II	1'000	550	10%	900	550	500	150	650	700
NX 6500 II	1'200	650	10%	1'050	650	550	150	700	800
T 3600D	650	370	40%	520	360	350	150	500	200
T 4000	650	400	40%	520	400	350	150	500	300
T 4000L	850	400	40%	700	400	350	150	500	300
VC 430	710	490	0%	560	430	570	150	720	300
VC 510	860	570	0%	762	516	570	210	780	350
VM 750	1'600	800	10%	1'500	750	800	200	1'000	3'000
VM 5400	1'200	540	10%	1'020	540	530	150	680	800
VM 6500	1'400	670	10%	1'270	670	625	150	775	1'000

* The recommended rotary tables can overhang the machine table by so many % (e.g. 10 % means: the rotary table length can be greater than dimension Y or X by max. 10 % of the machine width Y with Y-clamping or 10 % of the table length X with X-clamping.)

** The recommended rotary tables do not exceed 50 % of the allowed table load.

Table explanation for pp. 8–11

	EA-507 X2	EA-510 X2	EA-520 X2	EA-530 X2
DNM 4500	733	717	691	

Wherever values are listed, the combination is recommended. Empty cells mean that a combination is not possible, because the rotary table is too large, or is not recommended, because the rotary table is disproportionately small or heavier than 50% of the table load.

For further details about the rotary tables, see p. 12 and higher or refer to the main catalog



	EA-507 X2	EA-510 X2	EA-520 X2	EA-530 X2
DNM 4000	418	402	376	
DNM 4500	733	717	691	
DNM 500HS	943	927	901	872
DNM 5700	1'008	992	966	937
DNM 650HS			1'076	1'047
DNM 6700			1'191	1'162
DNM 750 II			1'421	1'392
DNM 400a	546	530	504	
DNM 400HS	674	658	632	
DT 360D	393	377	351	
DVM 500 II	943	927	901	872
DVM 650 II				
Mynx 5400	943	927	901	872
Mynx 6500			1'126	1'097
Mynx 7500			1'354	1'325
NX 5500 II	783	767	741	712
NX 6500 II		942	916	887
T 3600D	418	402	376	
T 4000	418	402	376	
T 4000L	608	592	566	
VC 430	468	452	426	
VC 510	644	628	602	573
VM 750			1'341	1'312
VM 5400	943	927	901	872
VM 6500			1'126	1'097

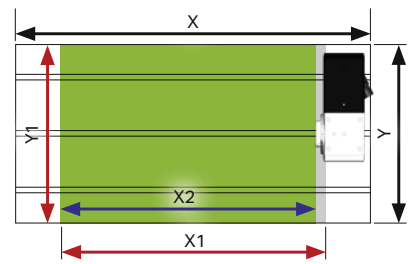

Rotary table installation with pL clamping claws in accordance with the operating manual

Clamping yokes for EA-type rotary tables

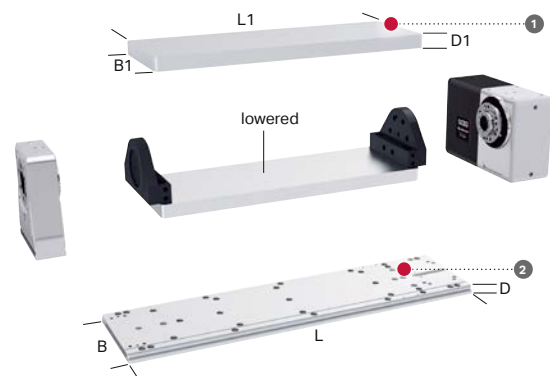

		EA-507	EA-510	EA-520	EA-530				
1 Clamping yokes	Sph [mm]	140	180	210	218				
	Length L1 [mm]	350 450	500 600	600 700 800	800 1000				
	Width B1 [mm]	165	215	270	270				
	Thickness D1 [mm]	20	35	40	40				
2 Base plates	Length L [mm]	622 722	785 885	916 1016 1116	1172 1372				
	Width B [mm]	168	248	301	368				
	Thickness D [mm]	30	30	30	38				
Weights / moments of inertia (without rotary table, without counter bearing)	Weight (Al) [kg]	10	12	23	28	40	45	52	on request
	Weight (steel) [kg]	29	34	66	80	117	130	152	
	Mom. inert. (Al) [kgm ²]	0.02	0.02	0.06	0.07	0.16	0.17	0.21	
	Mom. inert. (steel) [kgm ²]	0.04	0.05	0.17	0.21	0.46	0.50	0.60	

Explanations for pp. 8 to 11

The recommendations are for information purposes only. We recommend that you verify the effective dimensions prior to ordering. Modifications on the machine can lead to collisions and affect the dimensions X2 and Y2.



	M2-507	M2-510	M3-507	M3-510
	X2			
DNM 4000				
DNM 4500	674			
DNM 500HS	884	874	884	
DNM 5700	949	939	949	
DNM 650HS	1'059	1'049	1'059	1'049
DNM 6700	1'174	1'164	1'174	1'164
DNM 750 II	1'404	1'394	1'404	1'394
DNM 400a	487			
DNM 400HS	615			
DT 360D	334	324		
DVM 500 II	884	874	884	
DVM 650 II	1'059			
Mynx 5400	884	874	884	
Mynx 6500	1'109	1'099	1'109	1'099
Mynx 7500	1'337	1'327	1'337	1'327
NX 5500 II	724	714	724	
NX 6500 II	899	889	899	889
T 3600D	359	349		
T 4000	359	349		
T 4000L	549	539		
VC 430	409			
VC 510	585	575		
VM 750	1'324	1'314	1'324	1'314
VM 5400	884	874	884	
VM 6500	1'109	1'099	1'109	1'099

Y-mounting

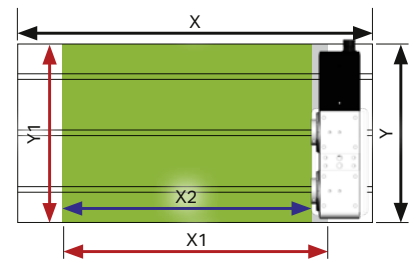

Rotary table installation with pL clamping claws in accordance with the operating manual

	M2-507	M2-510	M3-507	M3-510
	Y2			
DNM 4000	174	164	174	164
DNM 4500		214	224	214
DNM 500HS				304
DNM 5700				334
DNM 650HS				
DNM 6700				
DNM 750 II				
DNM 400a		199	209	199
DNM 400HS		199	209	199
DT 360D			142	
DVM 500 II				304
DVM 650 II				
Mynx 5400				304
Mynx 6500				
Mynx 7500				
NX 5500 II				314
NX 6500 II				
T 3600D			139	
T 4000			174	164
T 4000L			174	164
VC 430		224	234	224
VC 510			317	307
VM 750				
VM 5400				304
VM 6500				

X-mounting

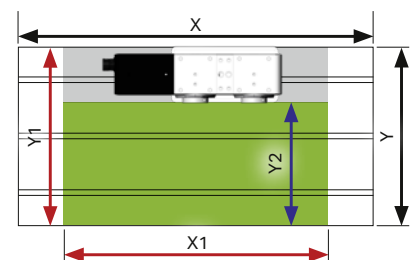

Rotary table installation with pL clamping claws in accordance with the operating manual

Y-mounting

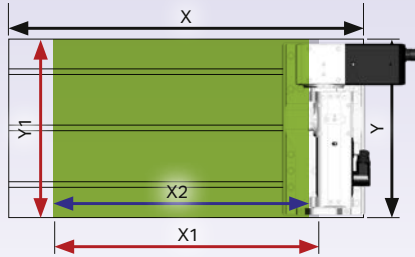

Rotary table installation using hole pattern in base plate



TIP1

TAP1

TOP1.2

	TIP1c TF-507510 X2	TIP2c TF-510520 X2	TIP3c TF-520530 X2	TAP1c T1-507510 X2	TAP2c T1-510520 X2	TAP3c T1-520530 X2	TAP1 T1-507510 X2	TAP2 T1-510520 X2	TAP3 T1-520530 X2	TOP1 T1-507510 X2
DNM 4000										
DNM 4500	770									
DNM 500HS	980	936		940			940			
DNM 5700	1'045	1'001		1'005	985		1'005			1'005
DNM 650HS	1'155	1'111	1'091	1'115	1'095	1'061	1'115	1'095		1'115
DNM 6700	1'270	1'226	1'206	1'230	1'210	1'176	1'230	1'210		1'230
DNM 750 II	1'500	1'456	1'436	1'460	1'440	1'406	1'460	1'440	1'406	1'460
DNM 400a	583									
DNM 400HS	711									
DT 360D	430			390						
DVM 500 II	980	936		940			940			
DVM 650 II	1'155									
Mynx 5400	980	936		940			940			
Mynx 6500	1'205	1'161	1'141	1'165	1'145	1'111	1'165	1'145		1'165
Mynx 7500	1'433	1'389	1'369	1'393	1'373	1'339	1'393	1'373	1'339	1'393
NX 5500 II	820	776		780	760		780			
NX 6500 II	995	951	931	955	935	901	955	935		955
T 3600D	455									
T 4000	455	411		415						
T 4000L	645	601		605						
VC 430	505									
VC 510	681	637		641			641			
VM 750	1'420	1'376	1'356	1'380	1'360	1'326	1'380	1'360	1'326	1'380
VM 5400	980	936		940			940			
VM 6500	1'205	1'161	1'141	1'165	1'145	1'111	1'165	1'145		1'165

	TOP2 T1-510520 X2	TOP3 T1-520530 X2	TAP1c.2 T1-507510 X2	TAP2c.2 T1-510520 X2	TAP3c.2 T1-520530 X2	TAP1.2 T1-507510 X2	TAP2.2 T1-510520 X2	TAP3.2 T1-520530 X2	TOP1.2 T2-507510 X2	TOP2.2 T2-510520 X2	TOP3.2 T2-520530 X2
DNM 4000											
DNM 4500											
DNM 500HS											
DNM 5700											
DNM 650HS	1'095		1'115			1'115					
DNM 6700	1'210		1'230			1'230					
DNM 750 II	1'440	1'406	1'460	1'440		1'460			1'460		
DNM 400a											
DNM 400HS											
DT 360D											
DVM 500 II											
DVM 650 II											
Mynx 5400											
Mynx 6500	1'145		1'165			1'165					
Mynx 7500	1'373		1'393	1'373		1'393			1'393		
NX 5500 II											
NX 6500 II	935		955			955					
T 3600D											
T 4000											
T 4000L											
VC 430											
VC 510											
VM 750	1'360	1'326	1'380	1'360		1'380	1'360		1'380		
VM 5400											
VM 6500	1'145		1'165			1'165					

X-mounting

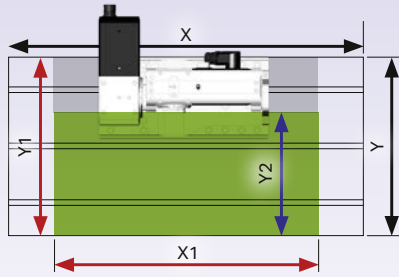

Rotary table installation using hole pattern in base plate



	TIP1c TF-507510 Y2	TIP2c TF-510520 Y2	TIP3c TF-520530 Y2	TAP1c T1-507510 Y2	TAP2c T1-510520 Y2	TAP3c T1-520530 Y2	TAP1 T1-507510 Y2	TAP2 T1-510520 Y2	TAP3 T1-520530 Y2	TOP1 T1-507510 Y2
DNM 4000	270	226	206	230	210		230	210		230
DNM 4500		276	256	280	260	226	280	260	226	280
DNM 500HS			346			316		350	316	370
DNM 5700						346		380	346	
DNM 650HS									446	
DNM 6700									446	
DNM 750 II										
DNM 400a		261	241	265	245		265	245		265
DNM 400HS		261	241	265	245		265	245		265
DT 360D		194					198			198
DVM 500 II			346			316		350	316	370
DVM 650 II										
Mynx 5400			346			316		350	316	370
Mynx 6500									446	
Mynx 7500										
NX 5500 II			356			326		360	326	380
NX 6500 II									426	
T 3600D		191		195			195			195
T 4000					210		230			230
T 4000L					210		230			230
VC 430		286		290	270		290			290
VC 510					353			353		373
VM 750										
VM 5400			346			316		350	316	370
VM 6500									446	

	TOP2 T1-510520 Y2	TOP3 T1-520530 Y2	TAP1c.2 T1-507510 Y2	TAP2c.2 T1-510520 Y2	TAP3c.2 T1-520530 Y2	TAP1.2 T1-507510 Y2	TAP2.2 T1-510520 Y2	TAP3.2 T1-520530 Y2	TOP1.2 T2-507510 Y2	TOP2.2 T2-510520 Y2	TOP3.2 T2-520530 Y2
DNM 4000	210		230			230					
DNM 4500	260		280	260		280	260		280	260	
DNM 500HS	350	316	370	350	316	370	350	316	370	350	316
DNM 5700	380	346	400	380	346	400	380	346	400	380	346
DNM 650HS		446		480	446		480	446	500	480	446
DNM 6700		446		480	446		480	446		480	446
DNM 750 II					537		571	537		571	537
DNM 400a	245		265	245		265			265		
DNM 400HS	245		265	245		265	245		265	245	
DT 360D			198								
DVM 500 II	350	316	370	350	316	370	350	316	370	350	316
DVM 650 II											
Mynx 5400	350	316	370	350	316	370	350	316	370	350	316
Mynx 6500		446		480	446		480	446	500	480	446
Mynx 7500		532			532		566	532		566	532
NX 5500 II	360	326	380	360		380	360		380	360	
NX 6500 II		426		460	426		460	426	480	460	426
T 3600D			195			195					
T 4000			230			230					
T 4000L			230	210		230			230		
VC 430			290			290			290		
VC 510	353		373	353		373	353		373	353	
VM 750					551			551		585	551
VM 5400	350	316	370	350	316	370	350	316	370	350	316
VM 6500		446		480	446		480	446	500	480	446



Very good accessibility, even with short tools

More space for workpieces and fixtures

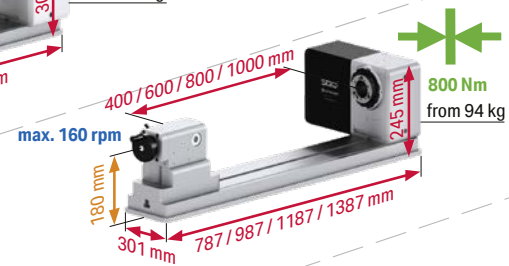
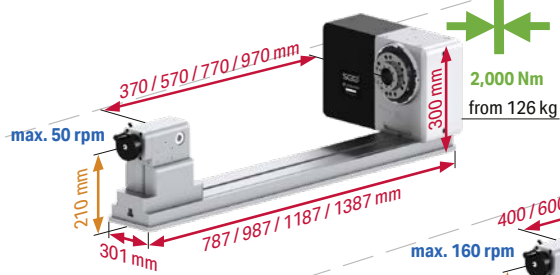
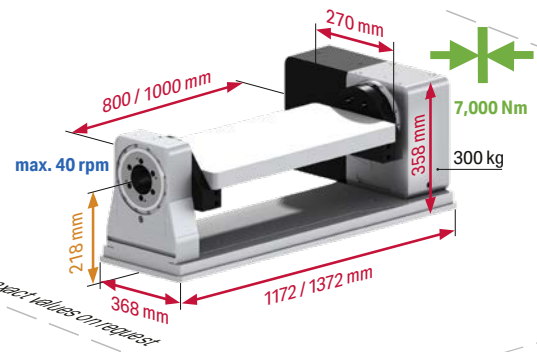
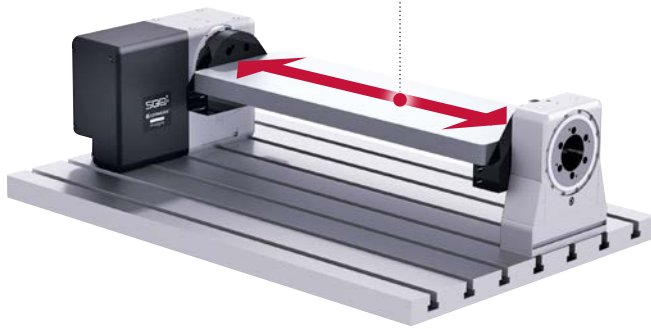

530

520

51x

50x

SIZE

Facts

1. High speed up to 210 rpm
2. Feed torque up to 850 Nm (tentative)
3. Steel base plates with hole pattern (suitable for slot spacing of 100 and 125 mm)
4. Cycle time 90° as fast as 0.21 sec.

 Weight data represent the standard load; higher weights possible, but require modification of rotational speed, acceleration and jerk limitation.

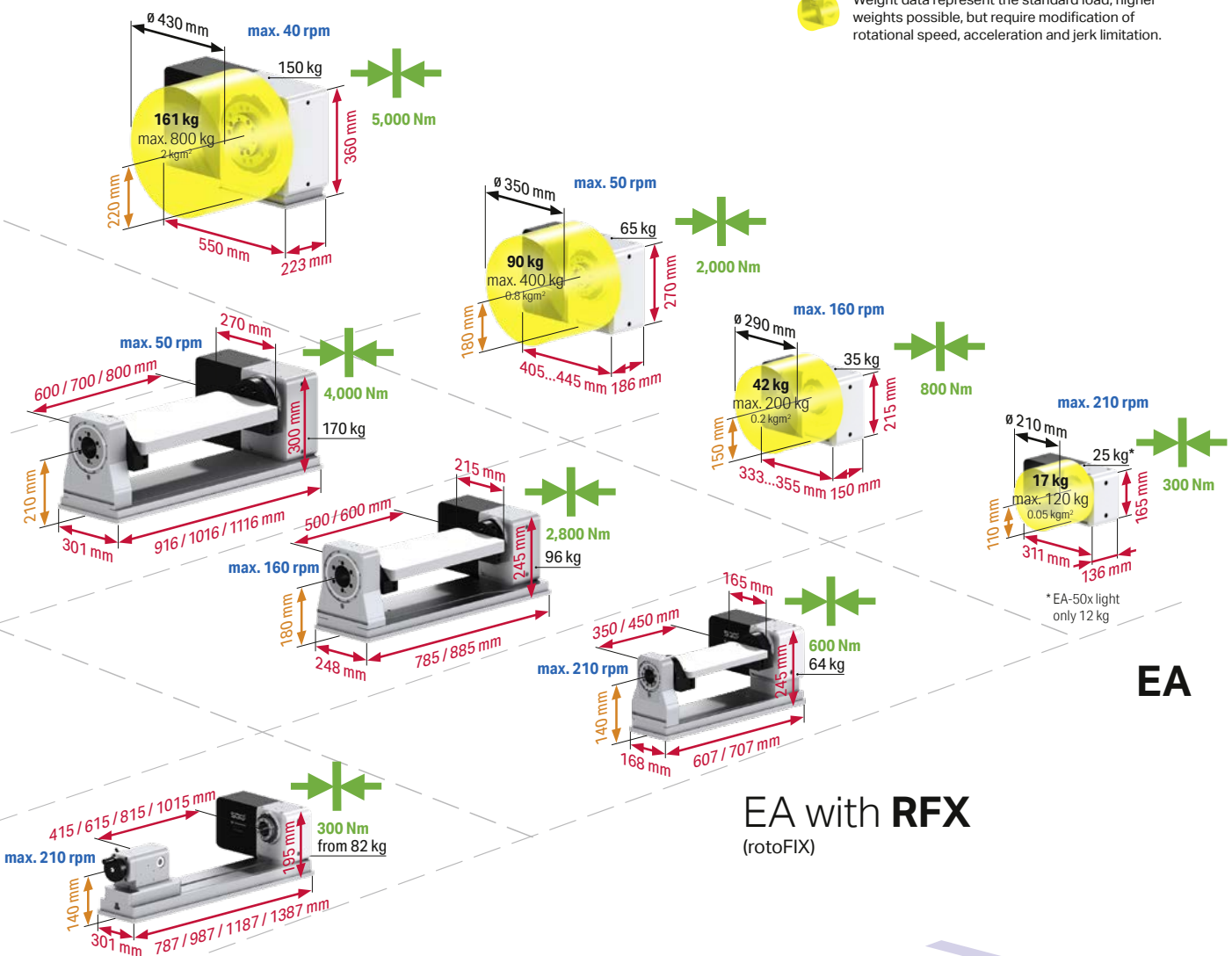

EA

EA with **RFX**
(rotoFIX)

EA with **LFX**
(longFLEX)

MODEL

50x	507 (standard) or 508 (high speed)
51x	510 (standard) or 511 (high speed)
EA	single-axis, single-spindle CNC rotary table
rotoFIX	modular clamping yoke system
longFLEX	modular shaft clamping system

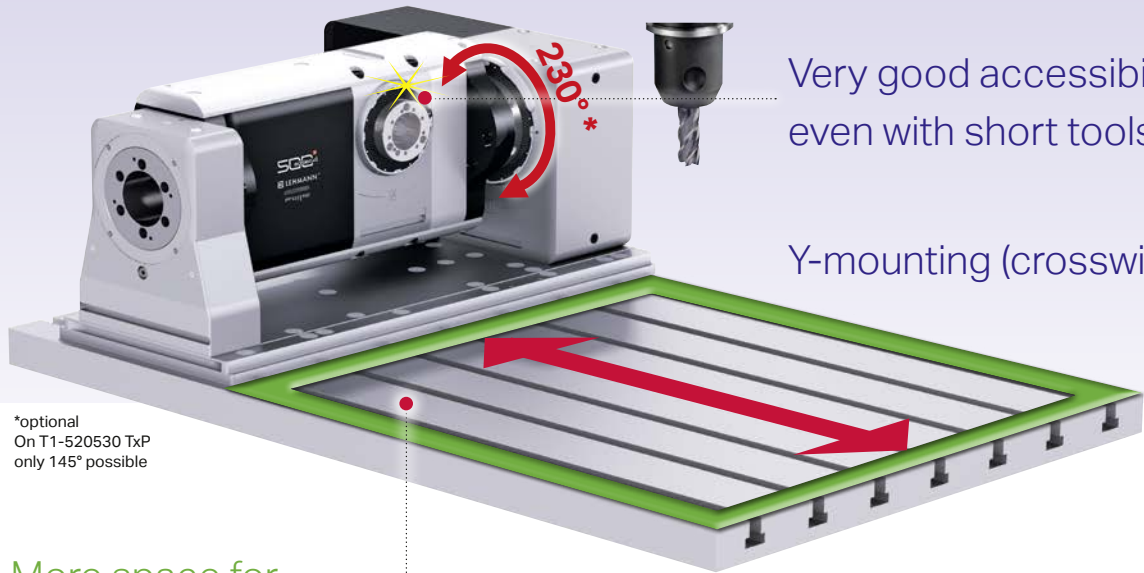

Very good accessibility, even with short tools

Y-mounting (crosswise)

*optional
On T1-520530 TxP
only 145° possible

More space for workpiece and fixtures

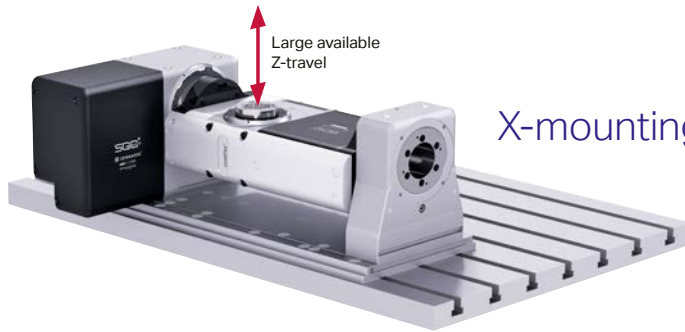

X-mounting (lengthwise)

T1

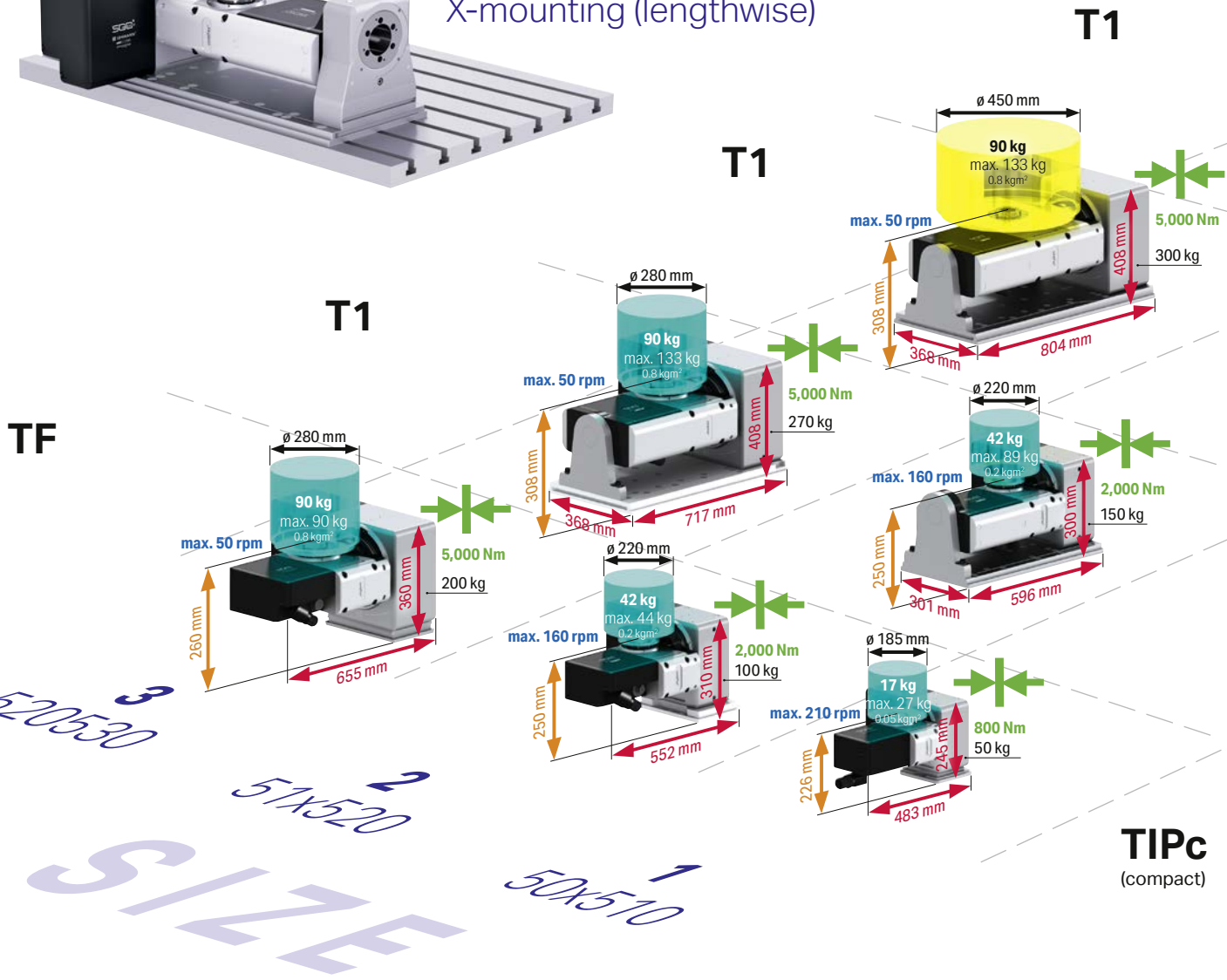

TF

T1

T1

TIPc
(compact)

SIZE

520530 3

51X520 2

50X510 1

Facts

1. Up to 150% higher clamping torque in tilting axis
2. Fewer variant – more solution
3. Larger workpiece \varnothing possible
4. Spatially optimized arrangement of the dividing axis

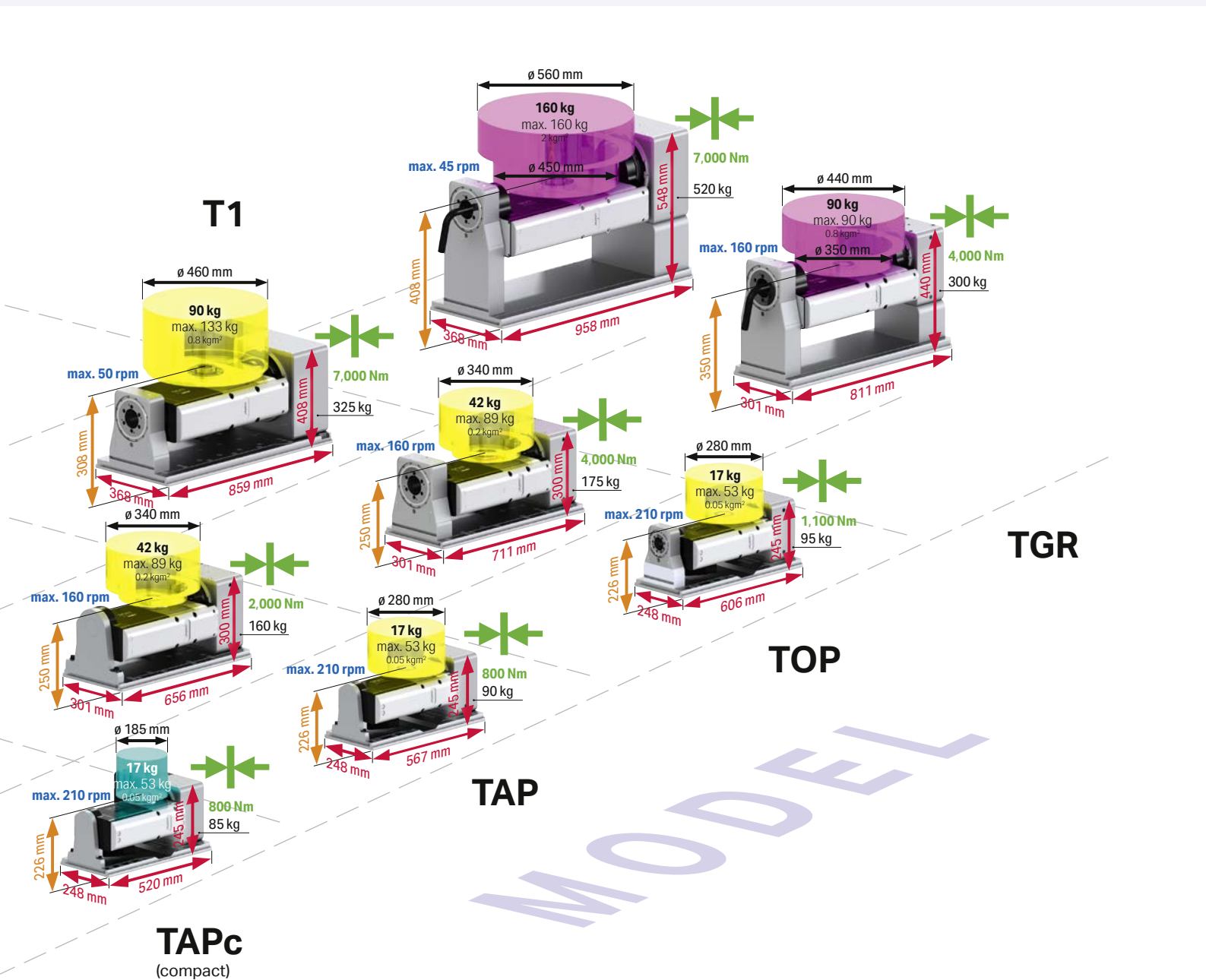

Weight data represent the standard load; higher weights possible, but require modification of rotational speed, acceleration and jerk limitation.

50x510	508510 (standard) or 508510 (high speed)
51x520	510520 (standard) or 511520 (high speed)
TIPc	Two-axis rotary table, no counter bearing, compact
TAPc	Two-axis rotary table, with supporting bearing, compact
TAP	Two-axis rotary table, with supporting bearing
TOP	Two-axis rotary table, with clamped counter bearing
TGR	Two-axis rotary table, with clamped counter bearing, specifically for grinding applications



More space for workpiece and fixtures

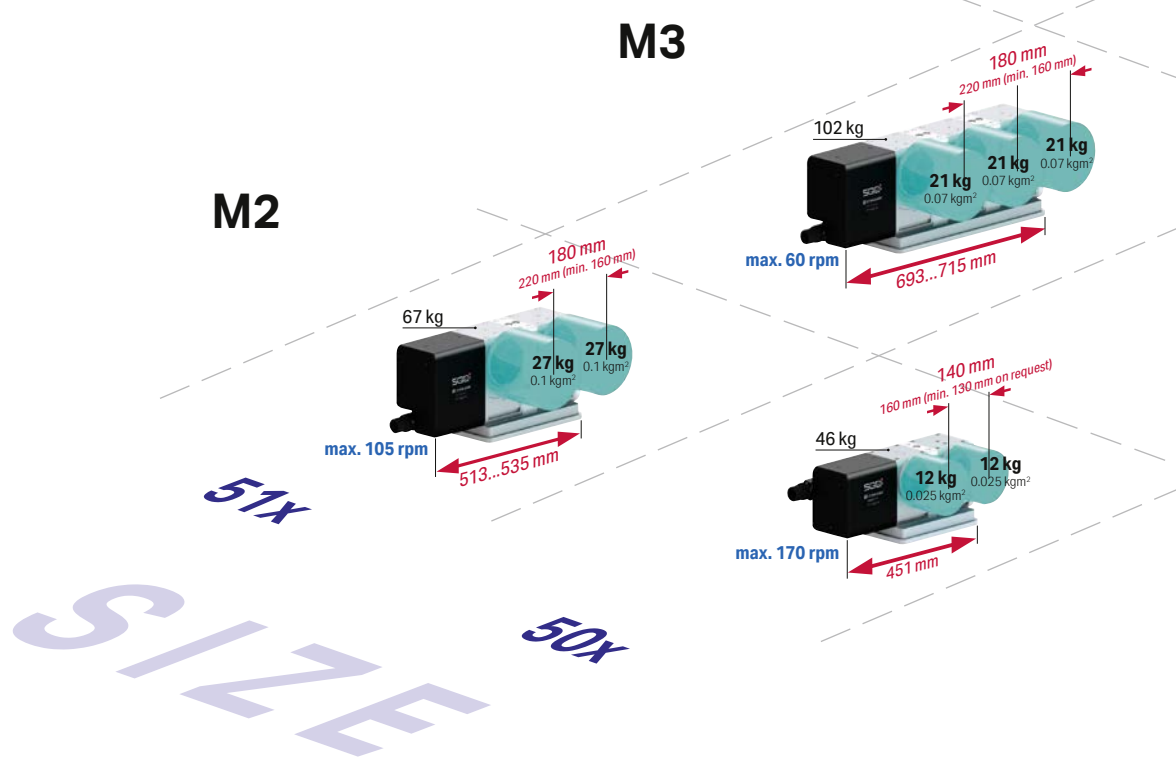

Facts

1. Up to 54 % higher clamping torque in tilting axis
2. Fewer variant – more solution
3. Spindle distance min. 130 mm
4. Spatially optimized arrangement of the dividing axis

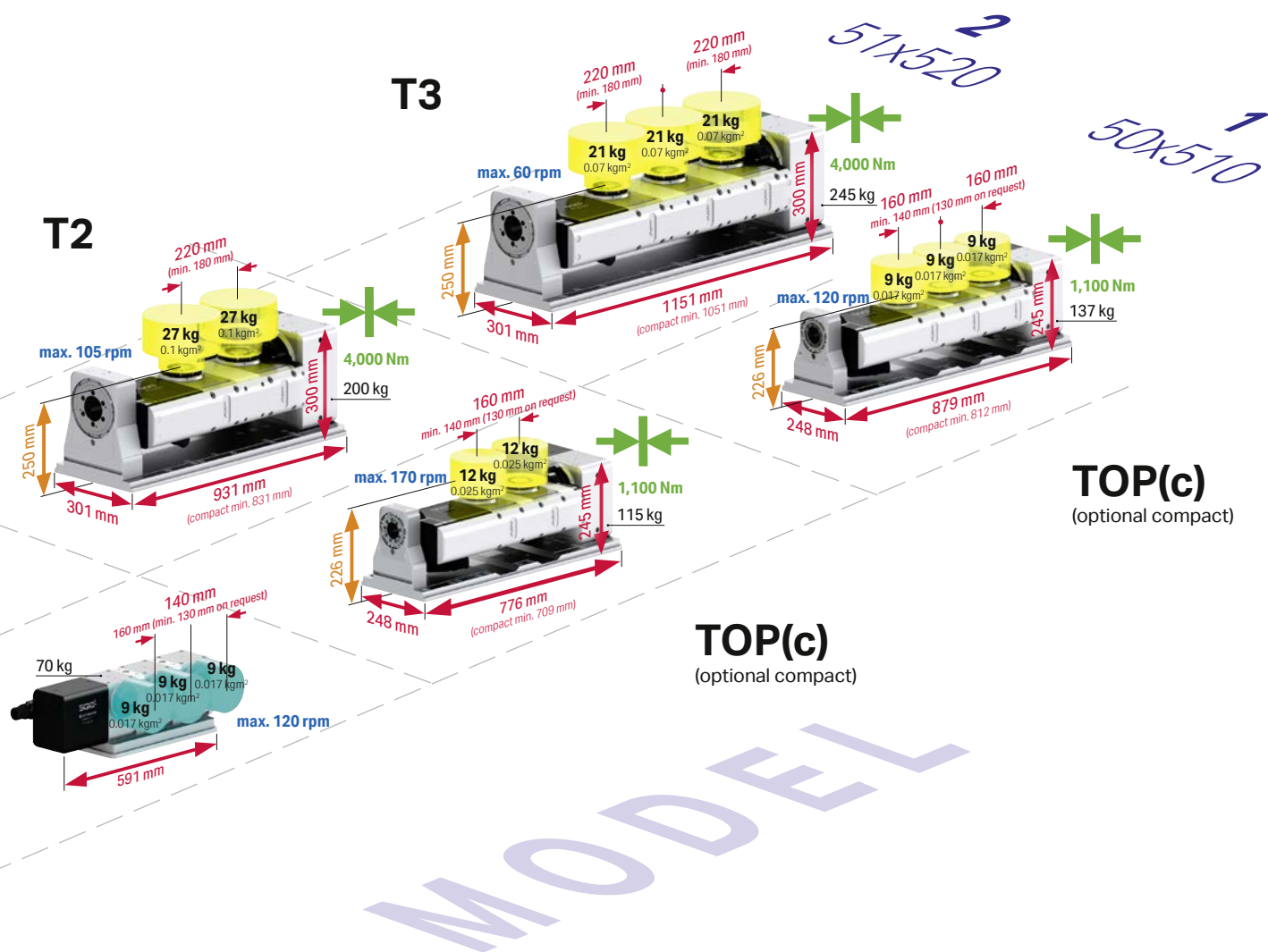

Weight data represent the standard load; higher weights possible, but require modification of rotational speed, acceleration and jerk limitation.

- 50x 507 (standard) or 508 (high speed)
- 51x 510 (standard) or 511 (high speed)
- M2 Single-axis, multi-spindle rotary table, 2-position
- M3 Single-axis, multi-spindle rotary table, 3-position
- T2 Two-axis multi-spindle rotary table, 2-position
- T3 Two-axis multi-spindle rotary table, 3-position

Extremely wide assortment for workpiece clamping.
Standardized interface in front and rear: maximum universality

Spindle accessories in rear

- + Rotary unions **up to 250 bar**
- + Clamping cylinder **23 kN at 120 bar**
- + Angular position measuring systems **as precise as ± 1 arcsec**

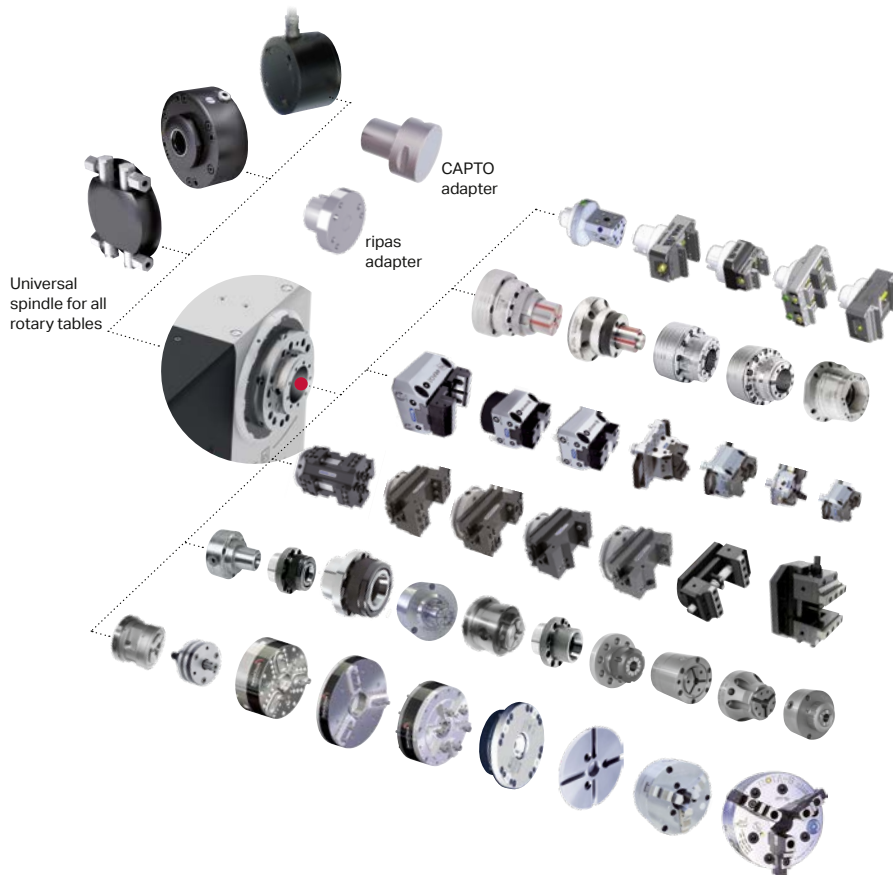

Spindle accessories in front



Tailstock and counter bearing



ripas zero point clamping system



EA-507 with ripas auto and ripas adapter

CAPTO clamping

NEW



EA-507 with CAPTO retrofit kit

Present in over 20 countries: from sales consultation to the final service



Services from A to Z

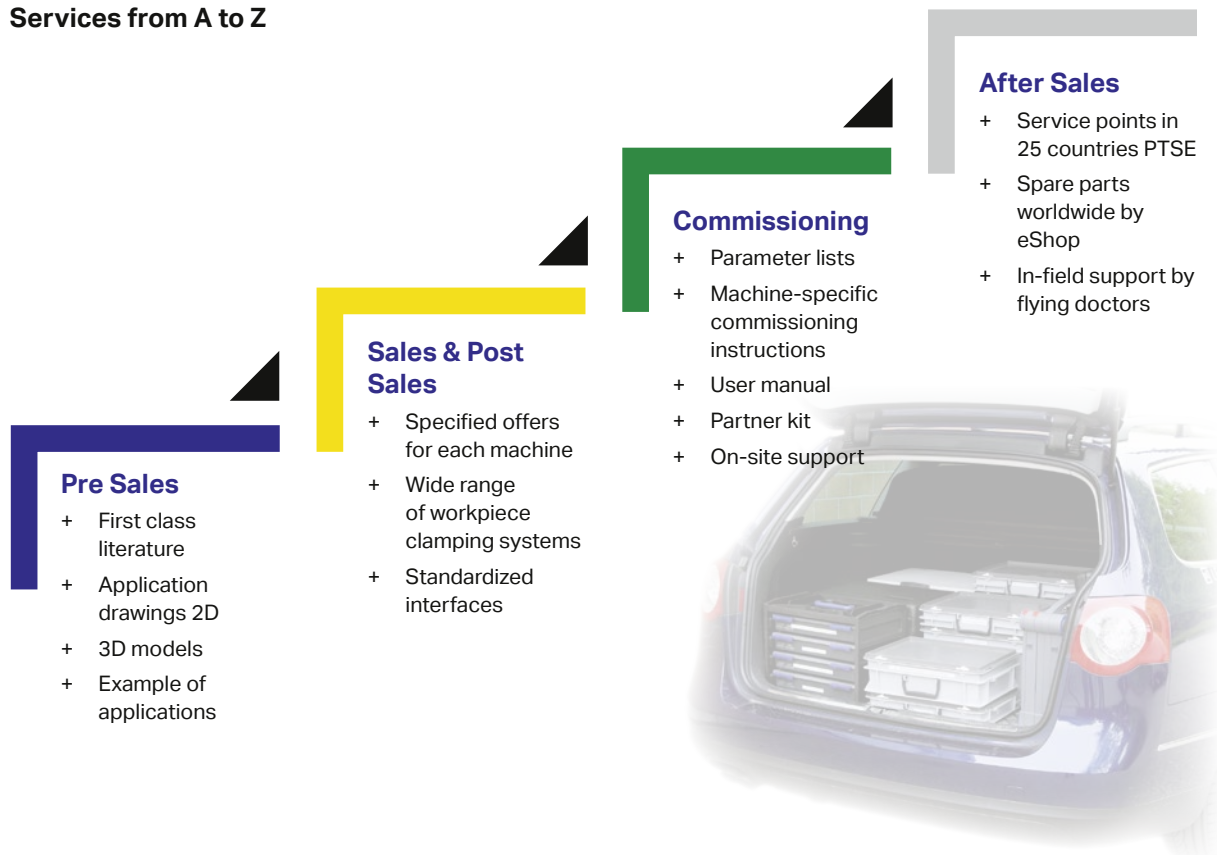

Increase productivity – Extend lifecycle

Comprehensive and professional services throughout the product life cycle – maximum availability with consistent quality and high productivity.

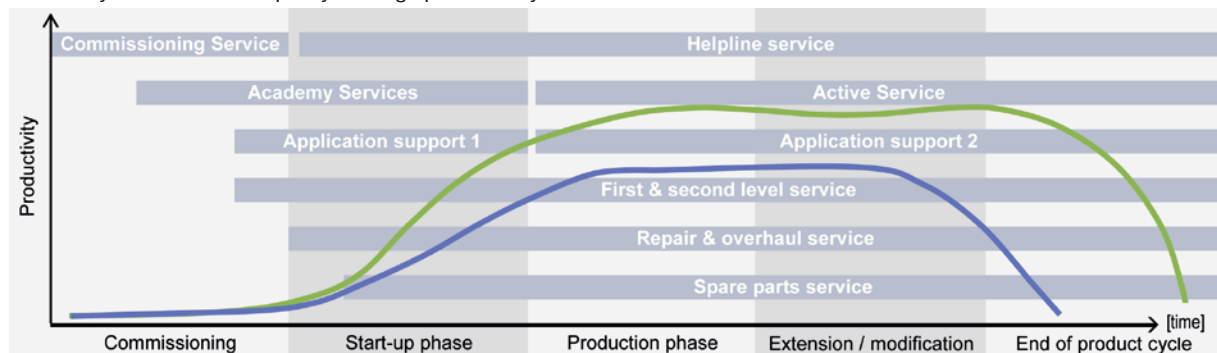

— Productivity with LifeCycle service products from pL LEHMANN
 — Productivity without service support

For more information please see www.lehmann-rotary-tables.com.



ROTARY TABLES · PRECISION TECHNOLOGY · SOFTWARE

Headquarters

PETER LEHMANN AG
CH-3552 Bârau
Phone +41 (0)34 409 66 66
Fax +41 (0)34 409 66 00
sales@plehmann.com
www.lehmann-rotary-tables.com

Global network

Europe

- Austria
- Benelux
- Czech Republic
- Denmark
- Finland
- France
- Germany
- Hungary
- Ireland
- Italy
- Norway
- Poland
- Portugal
- Russia
- Slovenia
- Spain
- Sweden
- Turkey
- UK

America

- Brazil
- Canada
- Mexico
- USA

Asia

- China
- India
- Japan
- Malaysia
- Singapore
- South Korea
- Taiwan
- Thailand
- Vietnam

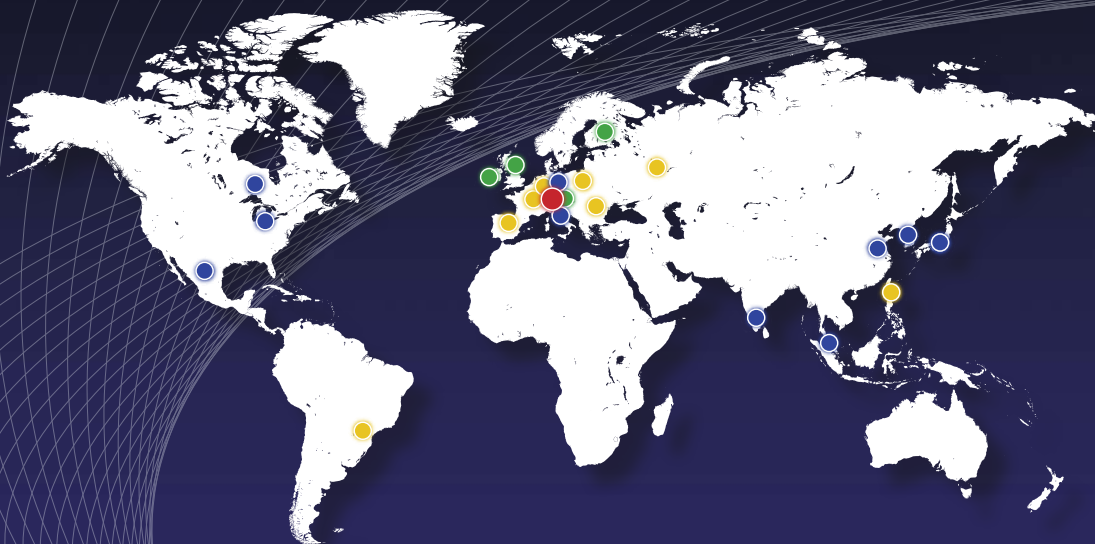

● Headquarters ● direct sales/service partner ● pL SOLUTIONS® partner ● value added reseller & partner

More information (address, telephone number...) at www.lehmann-rotary-tables.com