



# Selection Guide for CNC Rotary Tables ...



Bluetooth®

pl

LEADWELL

10/2021 | EN



... for vertical machining centers

CNC rotary tables for economical manufacturing:  
pL LEHMANN has suitable and rational solutions for  
nearly every industry

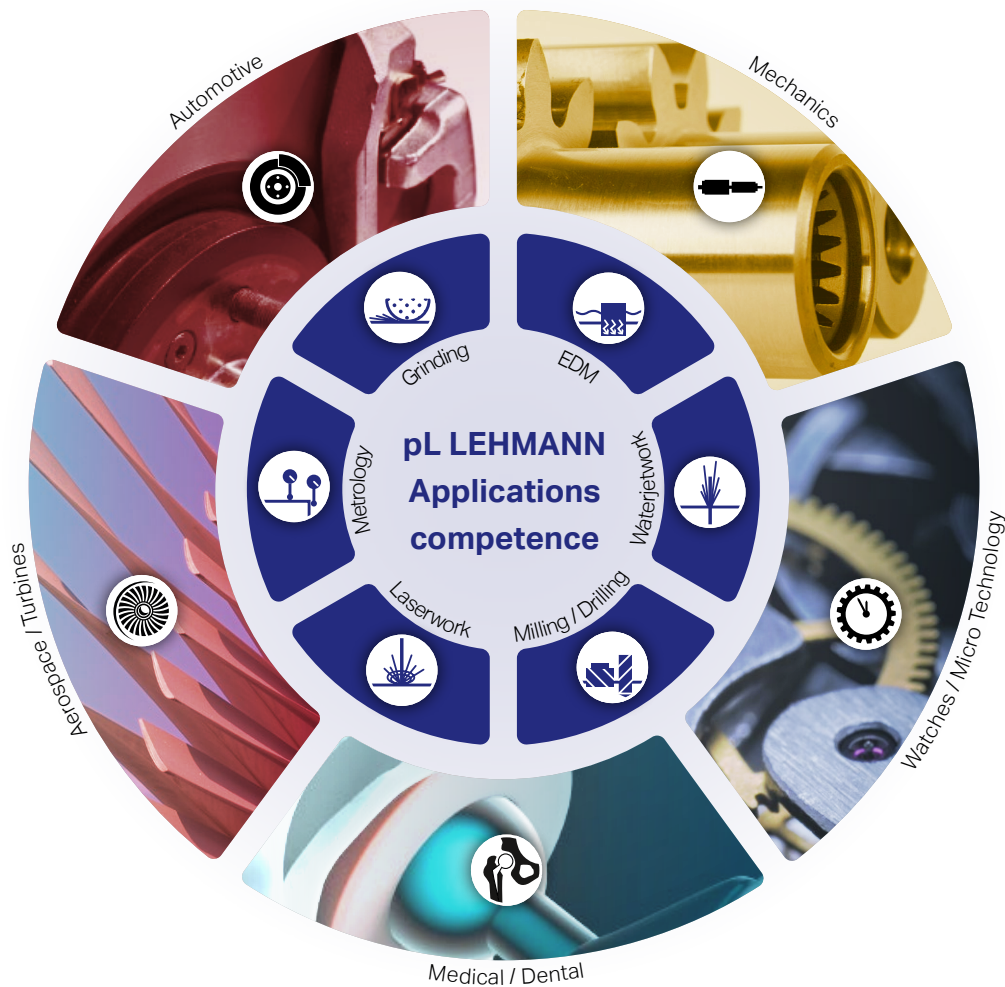

pL rotary tables in use: on over **40** different machine brands  
and over **160** different machine models.

pL competence: Integration in **all known** CNC control systems  
(Fanuc, Siemens, Heidenhain ...), for new machines as well as  
for retrofits

Professional products from professional partners:  
 LEADWELL and pL LEHMANN provide  
 first-class service to common customers

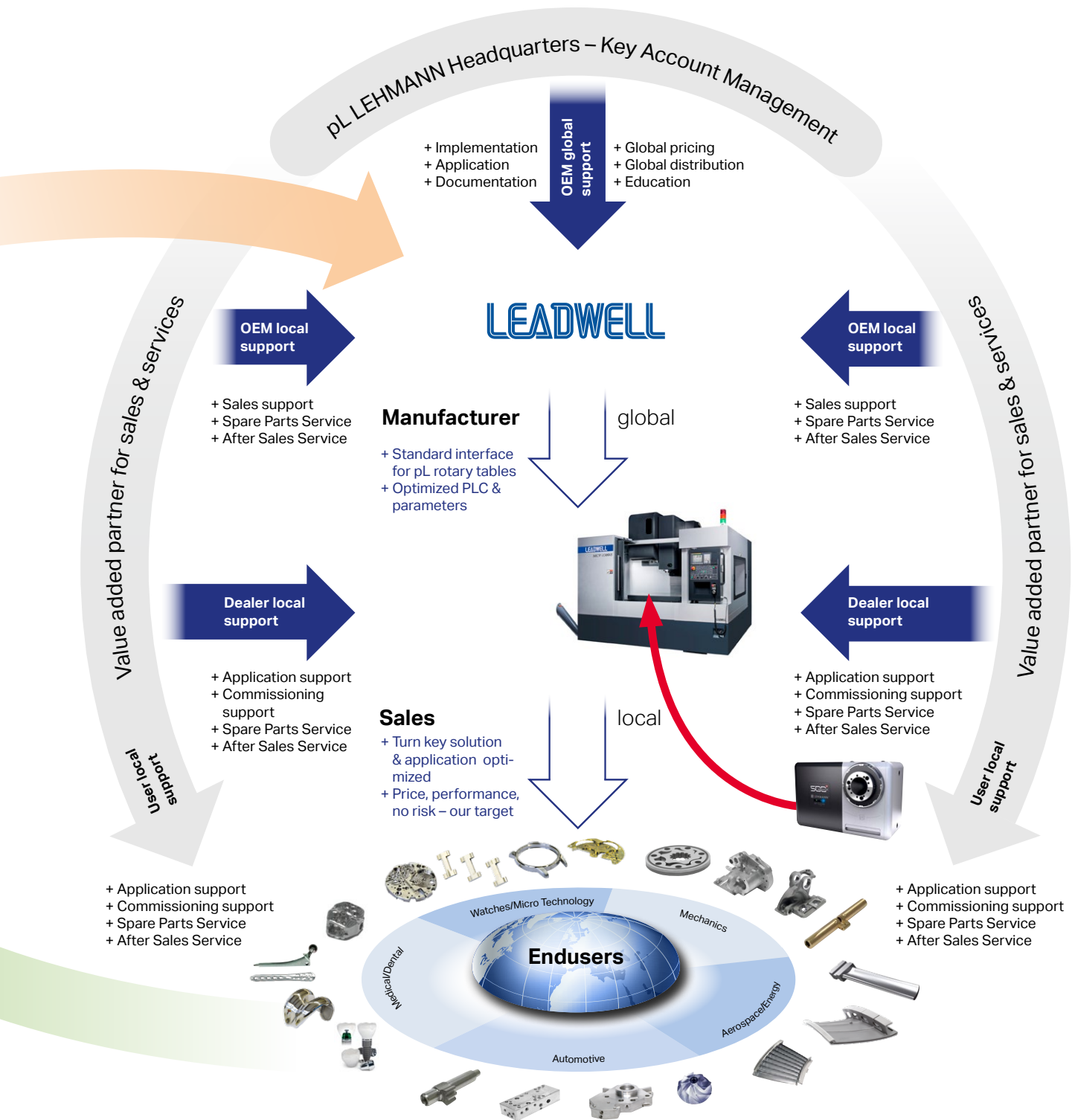

Up to 210 rpm  
up to 0.21 sec / 90°

**High speed GD**

Extended travel in  
Z- and X-direction

**More space**

High spindle load,  
heavy-duty bearing

**Heavy duty**

## E-Series



EA-50x light only 12 kg



## DD Series NEW

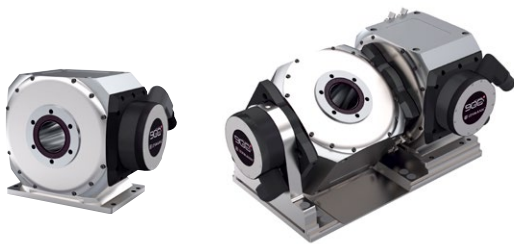

Request our  
special catalog

**High speed DD**

up to 5'450 rpm

**Adaptability**

Multifunctional  
spindle HSK

**Precision**

On the workpiece, as  
precise as 2 μm / 100 mm

Pneum. clamping  
up to 7,000 Nm

**High clamp**

Large parts  
up to  $\varnothing$  500

**Big size**

PGD backlash-free  
long-life gear unit

**No backlash**

## T-Series



**All base plates  
made of steel**

with integrated hole pattern for  
slot spacing of 100 and 125 mm,  
integrated alignment system  
**lineFIX** for lengthwise or cross-  
wise clamping.

## M-Series



**Connectivity**

Wireless monitoring,  
for operation & service

**No adjust**

Load change without  
parameter adjustment

**Less cost**

No cooling system,  
no hydraulics



MCV-1300iS



MCV-1500i



V-12iP



V-22iF/IR



V-30M



V-60i

## A word from LEADWELL:

### Quality Is Our Nature

LEADWELL's mission is to constantly search for excellence and gain respect in the industry. Using our 40 years of experience, the entire staff at LEADWELL pledges to bring innovation, quality assurance, world-class after sales service, and environmentally friendly machine tools to the worldwide marketplace. We strive to win the respect of both our customers and worldwide competitors alike.

The staff at LEADWELL is of one mind on quality. In work and in life they strive for the very best. They follow not only the rules and regulations but take it to higher plane by keeping quality in all that they do. With this quality culture LEADWELL produces superior machinery.

The LEADWELL brand stands for innovation in a rapidly changing world. Already LEADWELL is known for safety, speed, precision, and efficiency. We are bringing high-quality, innovative, reliable, competitive products to the machine tool market.







## Explanations for pp. 8 to 11

The recommendations are for information purposes only. We recommend that you verify the effective dimensions prior to ordering. Modifications on the machine can lead to collisions and affect the dimensions X2 and Y2.



	M2-507	M2-510	M3-507	M3-510
			X2	
MCV-1300iS	484	474	484	
MCV-1500i	549	539	549	539
V-12iP				
V-20S				
V-22iF/iR				
V-30iF/iR	204			
V-30M	224	214		
V-30S				
V-32AF/AR	219	209		
V-32iF/iR	219	209		
V-40iL	334	324	334	
V-42AF/AR	324	314		
V-42iF/iR	324	314		
V-50L	484	474	484	
V-52AF/AR	484	474		
V-60i	549	539	549	539
V-60S	549	539	549	

## Y-mounting

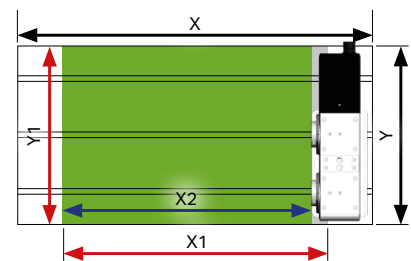

Rotary table installation with pL clamping claws in accordance with the operating manual

	M2-507	M2-510	M3-507	M3-510
			Y2	
MCV-1300iS				
MCV-1500i				
V-12iP	-26	-36	-26	
V-20S	-26	-36	-26	
V-22iF/iR	-26	-36	-26	
V-30iF/iR		-11	-1	-11
V-30M			24	14
V-30S	-26	-36	-26	-36
V-32AF/AR			24	14
V-32iF/iR			24	14
V-40iL				69
V-42AF/AR			24	14
V-42iF/iR			24	14
V-50L				
V-52AF/AR				
V-60i				
V-60S				

## X-mounting

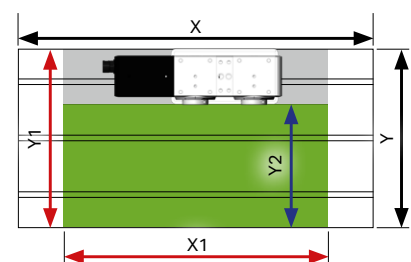

Rotary table installation with pL clamping claws in accordance with the operating manual

## Y-mounting

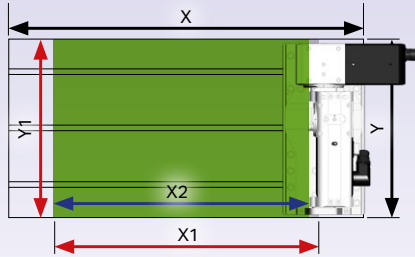

Rotary table installation using hole pattern in base plate



	TIP1c TF-507510 X2	TIP2c TF-510520 X2	TIP3c TF-520530 X2	TAP1c T1-507510 X2	TAP2c T1-510520 X2	TAP3c T1-520530 X2	TAP1 T1-507510 X2	TAP2 T1-510520 X2	TAP3 T1-520530 X2	TOP1 T1-507510 X2
MCV-1300iS	580	536	516	540	520		540	520		540
MCV-1500i	645	601	581	605	585	551	605	585	551	605
V-12iP										
V-20S										
V-22iF/iR										
V-30iF/iR	300									
V-30M	320	276		280						
V-30S										
V-32AF/AR	315	271		275						
V-32iF/iR	315	271		275						
V-40iL	430	386	366	390	370		390	370		390
V-42AF/AR	420	376		380						
V-42iF/iR	420	376		380						
V-50L	580	536	516	540	520		540	520		540
V-52AF/AR	580	536		540						
V-60i	645	601	581	605	585	551	605	585	551	605
V-60S	645	601	581	605	585		605	585		605

	TOP2 T1-510520 X2	TOP3 T1-520530 X2	TAP1c.2 T1-507510 X2	TAP2c.2 T1-510520 X2	TAP3c.2 T1-520530 X2	TAP1.2 T1-507510 X2	TAP2.2 T1-510520 X2	TAP3.2 T1-520530 X2	TOP1.2 T2-507510 X2	TOP2.2 T2-510520 X2	TOP3.2 T2-520530 X2
MCV-1300iS			540								
MCV-1500i	585		605	585		605			605		
V-12iP											
V-20S											
V-22iF/iR											
V-30iF/iR											
V-30M											
V-30S											
V-32AF/AR											
V-32iF/iR											
V-40iL			390								
V-42AF/AR											
V-42iF/iR											
V-50L			540								
V-52AF/AR											
V-60i	585		605	585		605			605		
V-60S			605								

## X-mounting

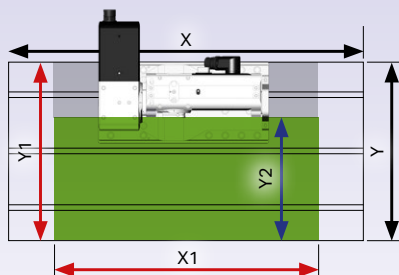

Rotary table installation using hole pattern in base plate



TIP1

TAP1

TOP1.2

	TIP1c TF-507510	TIP2c TF-510520	TIP3c TF-520530	TAP1c T1-507510	TAP2c T1-510520	TAP3c T1-520530	TAP1 T1-507510	TAP2 T1-510520	TAP3 T1-520530	TOP1 T1-507510
	Y2	Y2	Y2	Y2	Y2	Y2	Y2	Y2	Y2	Y2
MCV-1300iS										81
MCV-1500i										
V-12iP	70	26		30	10		30			
V-20S	70	26	6	30	10		30	10		30
V-22iF/iR	70	26	6	30	10		30	10		30
V-30iF/iR		51	31	55	35	1	55	35	1	55
V-30M			56		60	26	80	60	26	80
V-30S	70	26	6	30	10	-24	30	10	-24	30
V-32AF/iR			56		60	26	80	60	26	80
V-32iF/iR			56		60	26	80	60	26	80
V-40iL						81				81
V-42AF/iR			56		60	26	80	60	26	80
V-42iF/iR			56		60	26	80	60	26	80
V-50L										81
V-52AF/iR										26
V-60i										
V-60S										81

	TOP2 T1-510520	TOP3 T1-520530	TAP1c.2 T1-507510	TAP2c.2 T1-510520	TAP3c.2 T1-520530	TAP1.2 T1-507510	TAP2.2 T1-510520	TAP3.2 T1-520530	TOP1.2 T2-507510	TOP2.2 T2-510520	TOP3.2 T2-520530
	Y2	Y2	Y2	Y2	Y2	Y2	Y2	Y2	Y2	Y2	Y2
MCV-1300iS	115	81		115	81		115	81	135	115	81
MCV-1500i		151			151		185	151		185	151
V-12iP											
V-20S			30								
V-22iF/iR			30								
V-30iF/iR	35	1	55	35		55	35		55	35	
V-30M	60	26	80	60		80	60		80	60	
V-30S	10	-24	30	10		30	10		30	10	
V-32AF/iR	60	26	80	60		80	60		80	60	
V-32iF/iR	60	26	80	60		80	60		80	60	
V-40iL	115	81		115	81	135	115	81	135	115	
V-42AF/iR	60	26	80	60	26	80	60		80	60	
V-42iF/iR	60	26	80	60	26	80	60		80	60	
V-50L	115	81		115	81		115	81	135	115	81
V-52AF/iR	60	26		60	26		60	26	80	60	26
V-60i		151			151		185	151		185	151
V-60S		81		115	81		115	81		115	81



Very good accessibility, even with short tools

More space for workpieces and fixtures

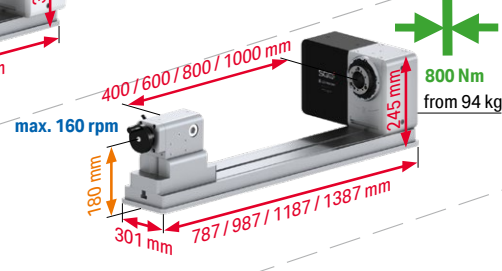
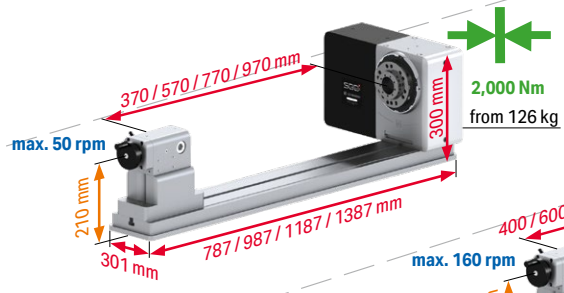
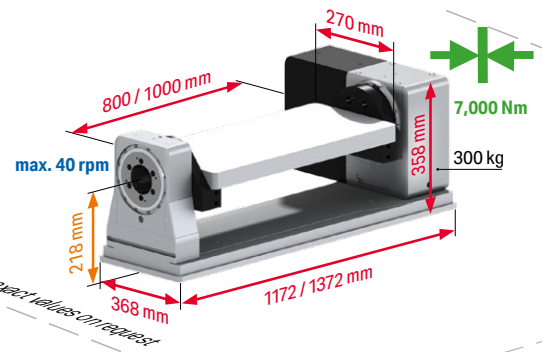
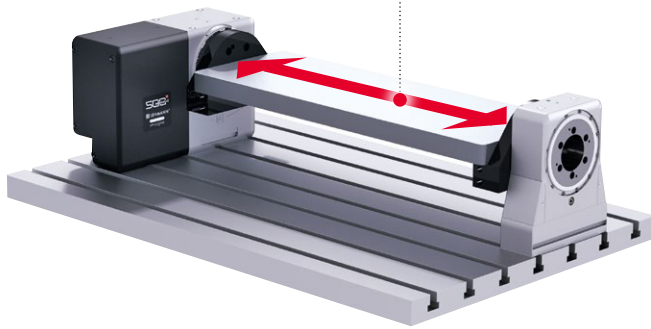

530

520

51x

50x

SIZE

### Facts

1. High speed up to 210 rpm
2. Feed torque up to 850 Nm (tentative)
3. Steel base plates with hole pattern (suitable for slot spacing of 100 and 125 mm)
4. Cycle time 90° as fast as 0.21 sec.

 Weight data represent the standard load; higher weights possible, but require modification of rotational speed, acceleration and jerk limitation.

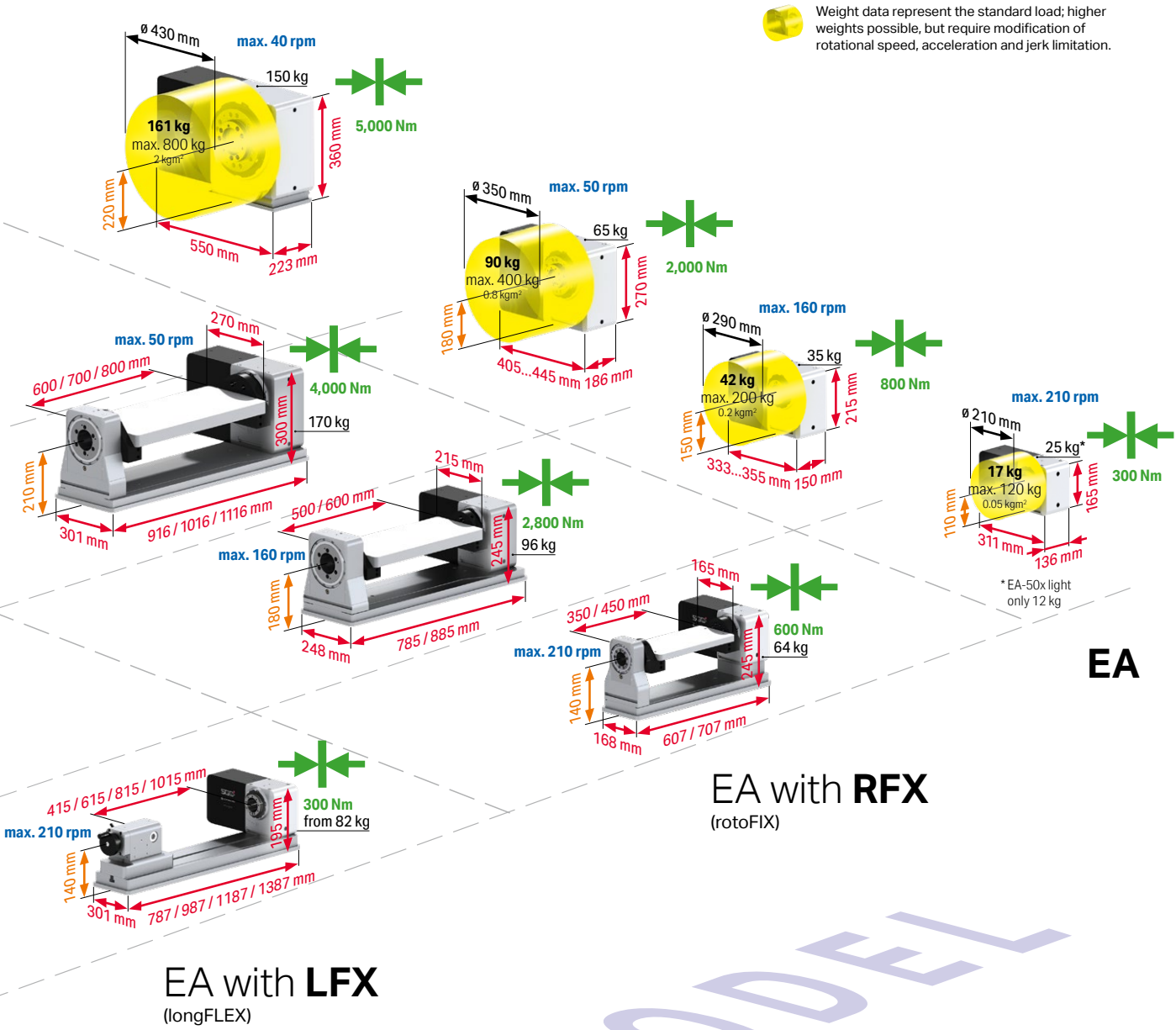

50x	507 (standard) or 508 (high speed)
51x	510 (standard) or 511 (high speed)
EA	single-axis, single-spindle CNC rotary table
rotoFIX	modular clamping yoke system
longFLEX	modular shaft clamping system

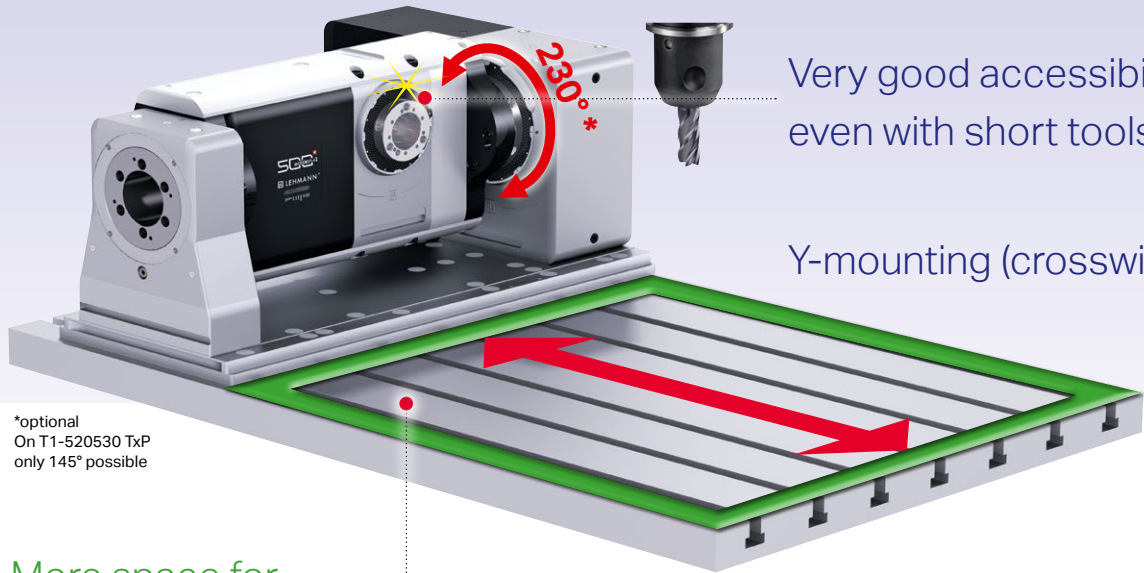

Very good accessibility, even with short tools

Y-mounting (crosswise)

\*optional  
On T1-520530 TxP  
only 145° possible

More space for workpiece and fixtures

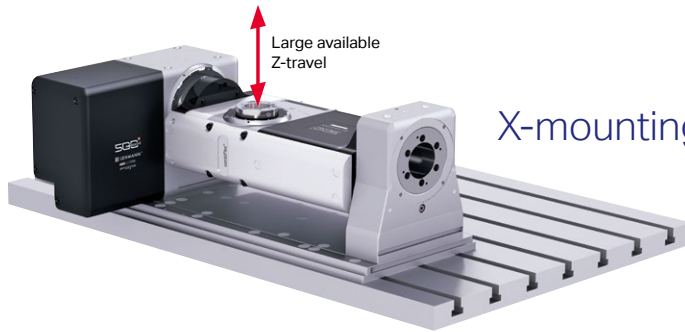

X-mounting (lengthwise)

**T1**

**TF**

**T1**

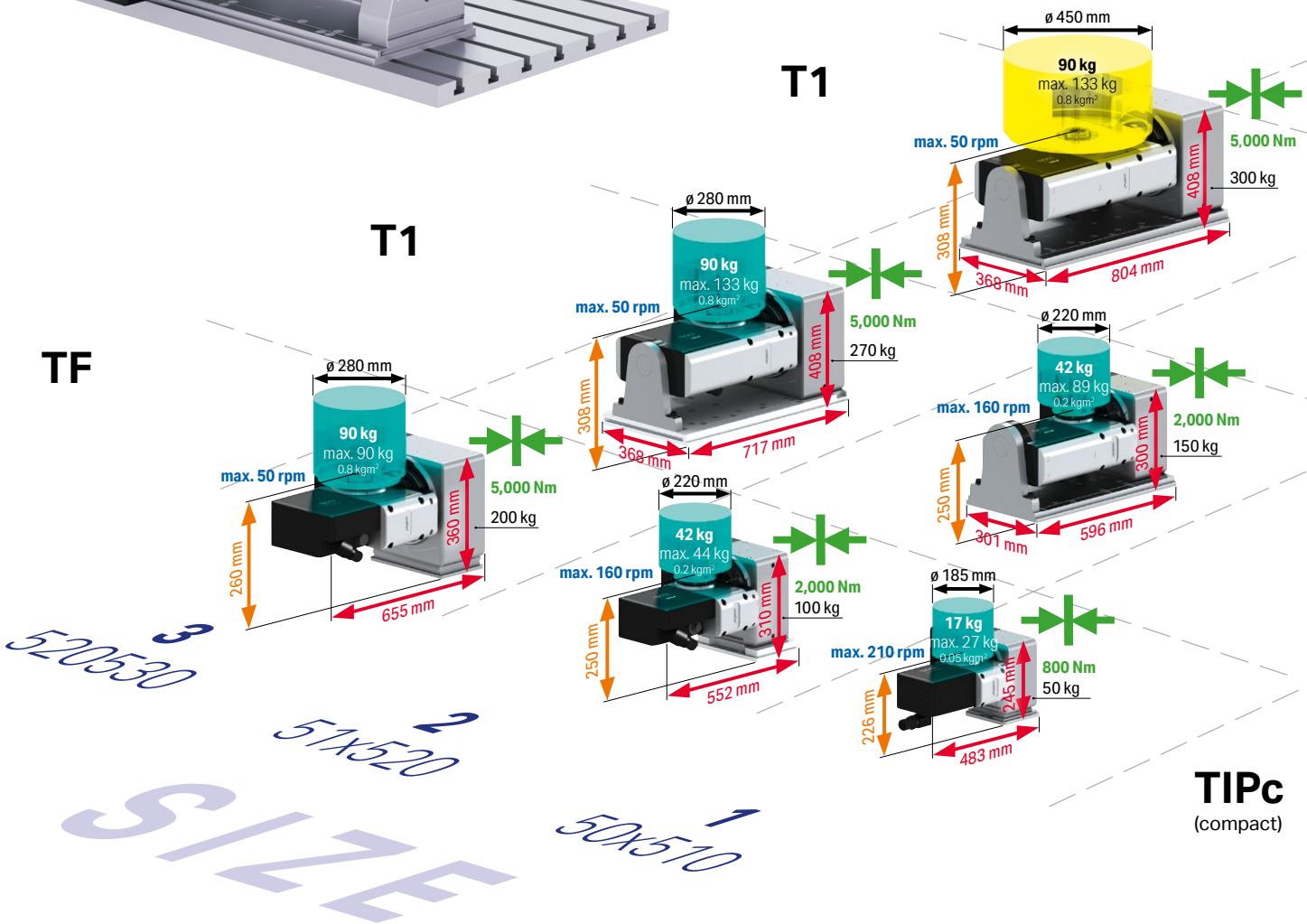

## Facts

1. Up to 150% higher clamping torque in tilting axis
2. Fewer variant – more solution
3. Larger workpiece  $\varnothing$  possible
4. Spatially optimized arrangement of the dividing axis

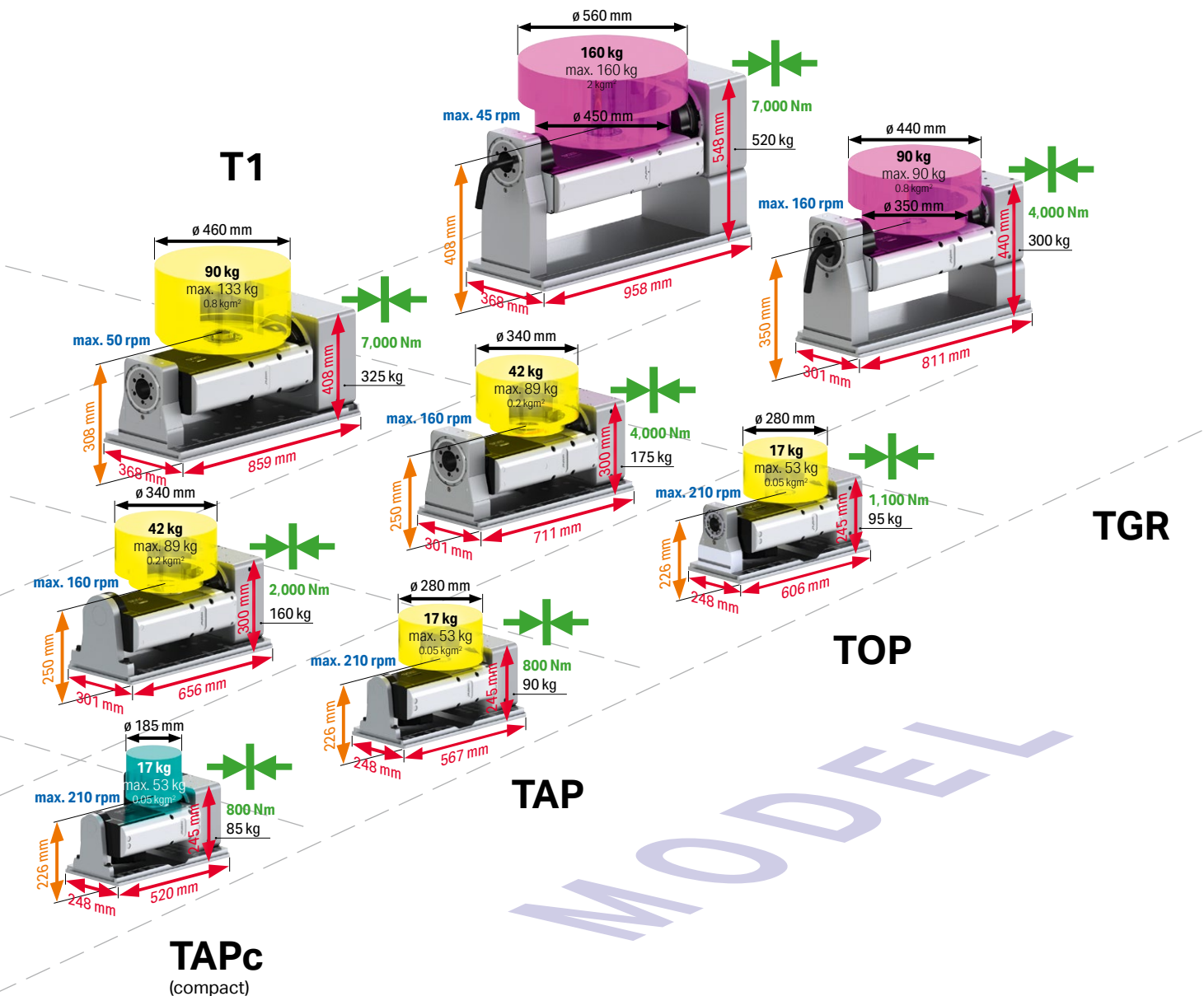

Weight data represent the standard load; higher weights possible, but require modification of rotational speed, acceleration and jerk limitation.

- 50x510 508510 (standard) or 508510 (high speed)
- 51x520 510520 (standard) or 511520 (high speed)
- TIPc Two-axis rotary table, no counter bearing, compact
- TAPc Two-axis rotary table, with supporting bearing, compact
- TAP Two-axis rotary table, with supporting bearing
- TOP Two-axis rotary table, with clamped counter bearing
- TGR Two-axis rotary table, with clamped counter bearing, specifically for grinding applications



More space for workpiece and fixtures

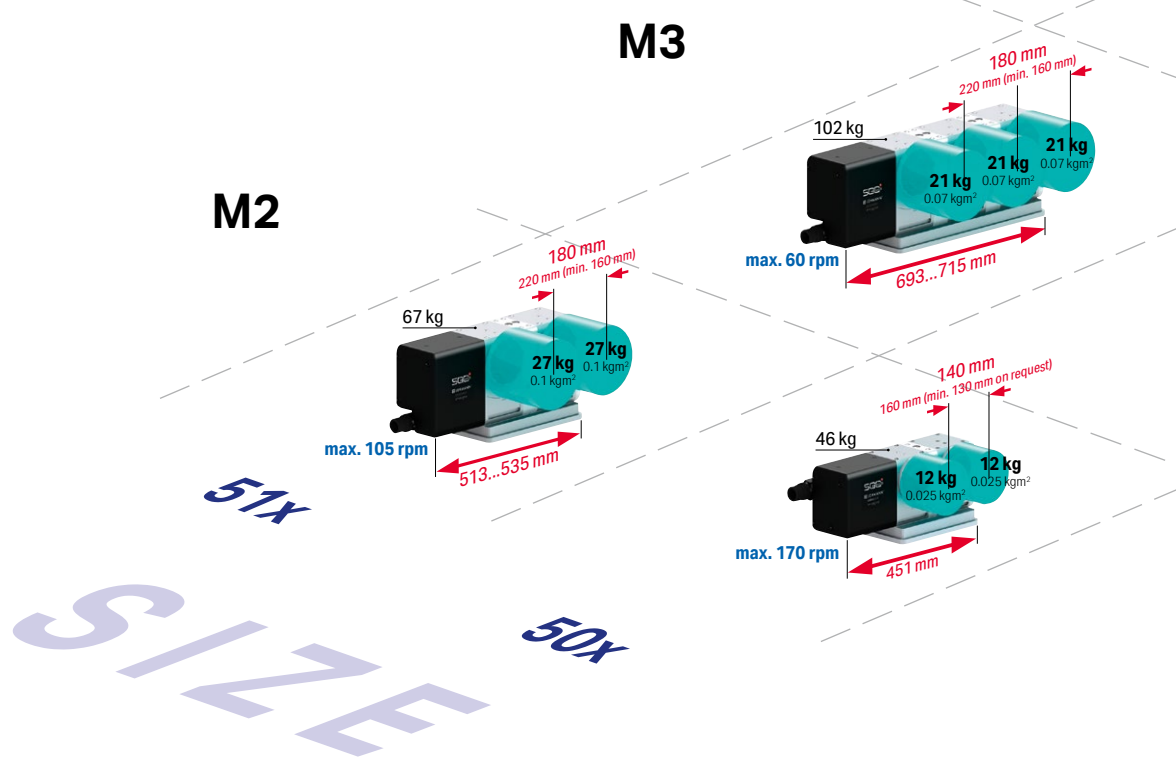



### Facts

1. Up to **54 %** higher clamping torque in tilting axis
2. Fewer variant – more solution
3. Spindle distance min. **130 mm**
4. Spatially optimized arrangement of the dividing axis

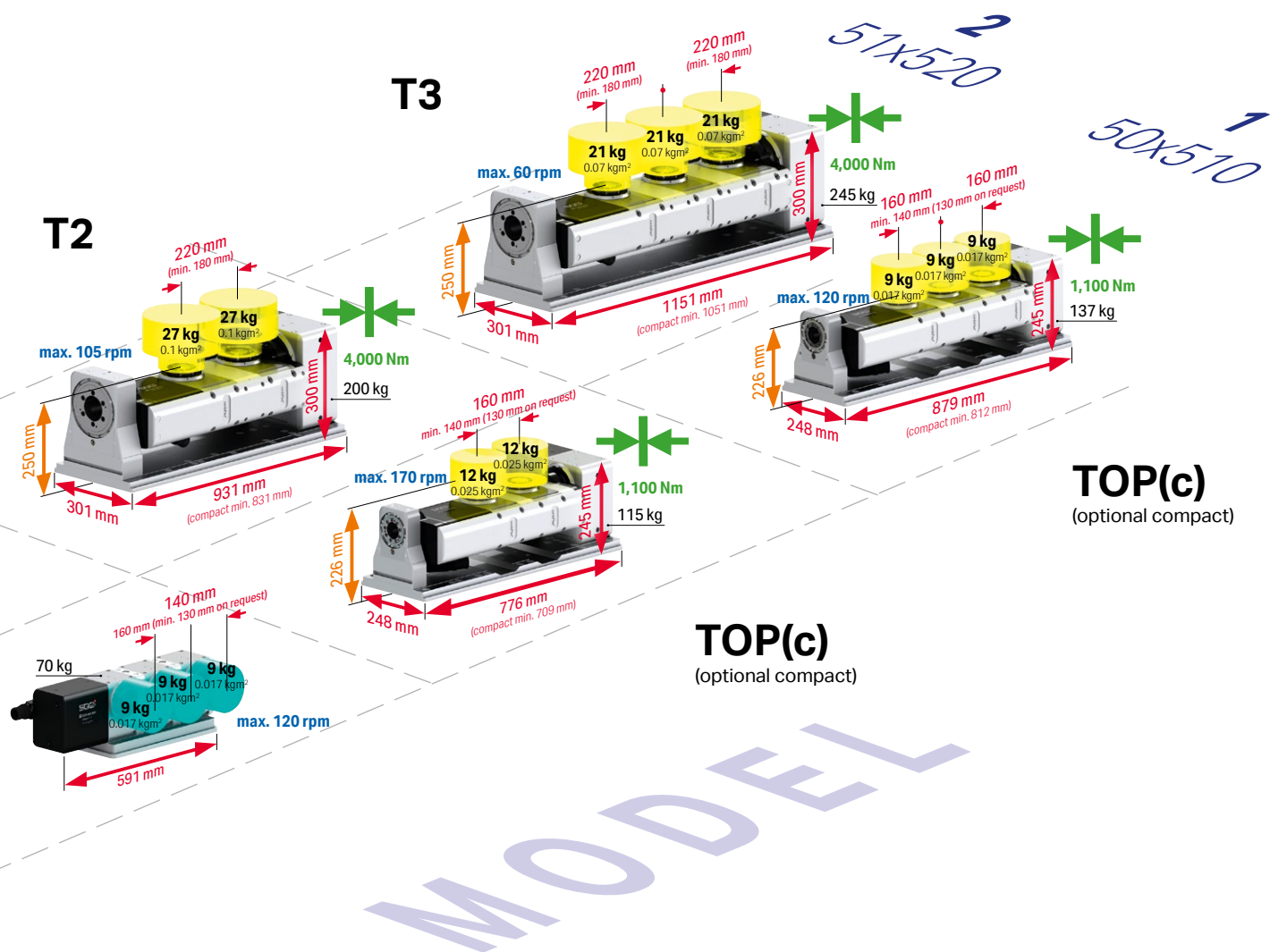

 Weight data represent the standard load; higher weights possible, but require modification of rotational speed, acceleration and jerk limitation.

- 50x 507 (standard) or 508 (high speed)
- 51x 510 (standard) or 511 (high speed)
- M2 Single-axis, multi-spindle rotary table, 2-position
- M3 Single-axis, multi-spindle rotary table, 3-position
- T2 Two-axis multi-spindle rotary table, 2-position
- T3 Two-axis multi-spindle rotary table, 3-position

Extremely wide assortment for workpiece clamping.  
Standardized interface in front and rear: maximum universality

## Spindle accessories in rear

- + Rotary unions **up to 250 bar**
- + Clamping cylinder **23 kN at 120 bar**
- + Angular position measuring systems **as precise as  $\pm 1$  arcsec**

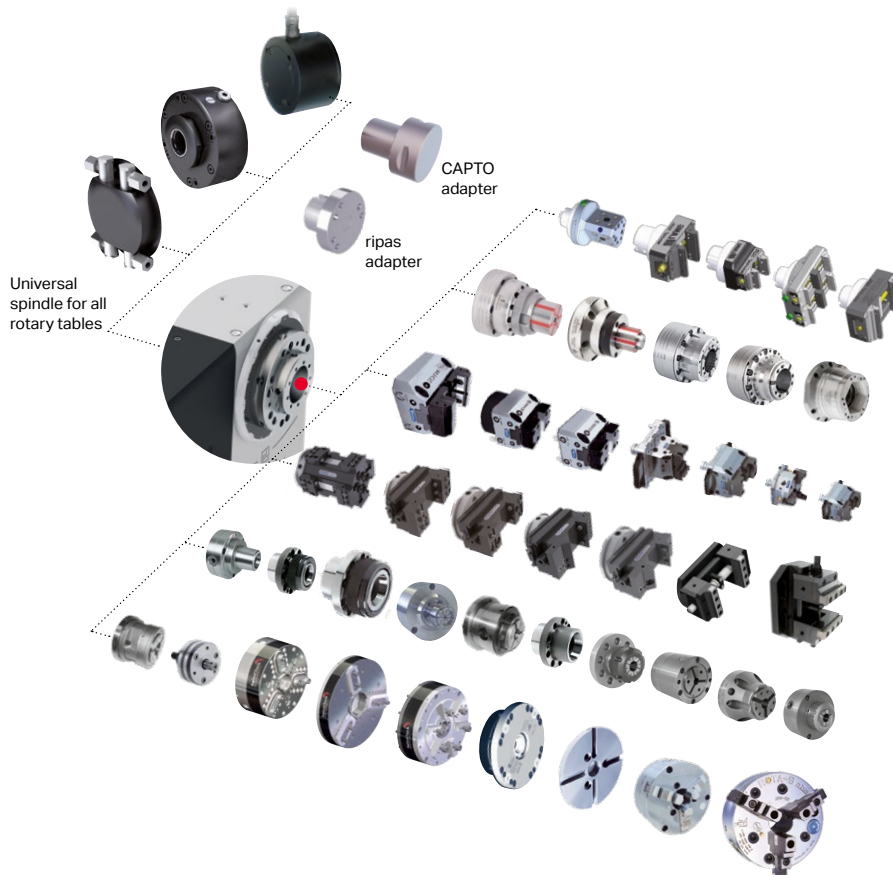

## Spindle accessories in front



## Tailstock and counter bearing



## ripas zero point clamping system



EA-507 with ripas auto and ripas adapter

## CAPTO clamping



EA-507 with CAPTO retrofit kit

unique

NEW

Present in over 20 countries: from sales consultation to the final service



### Get an offer

Please send us your request with the following information:

1. Do you need a 4<sup>th</sup> or 4<sup>th</sup>/5<sup>th</sup> axis?
2. On which machine should the rotary table get installed?  
(Name and exact type; e.g. DMG MORI 850V)
3. Which controller is on the machine?  
(Name and exact type; e.g. Heidenhain TNC 640)
4. What do you want to process on your machine?
  - Workpiece size
  - Weight
  - Material
  - Size of the series (number of pieces/year)
  - Loading and unloading (automatic or manual)
5. Is the machine completely prepared for the 4<sup>th</sup> or 4<sup>th</sup>/5<sup>th</sup> axis  
(PLC, software activation, hardware interface)?

### Services from A to Z

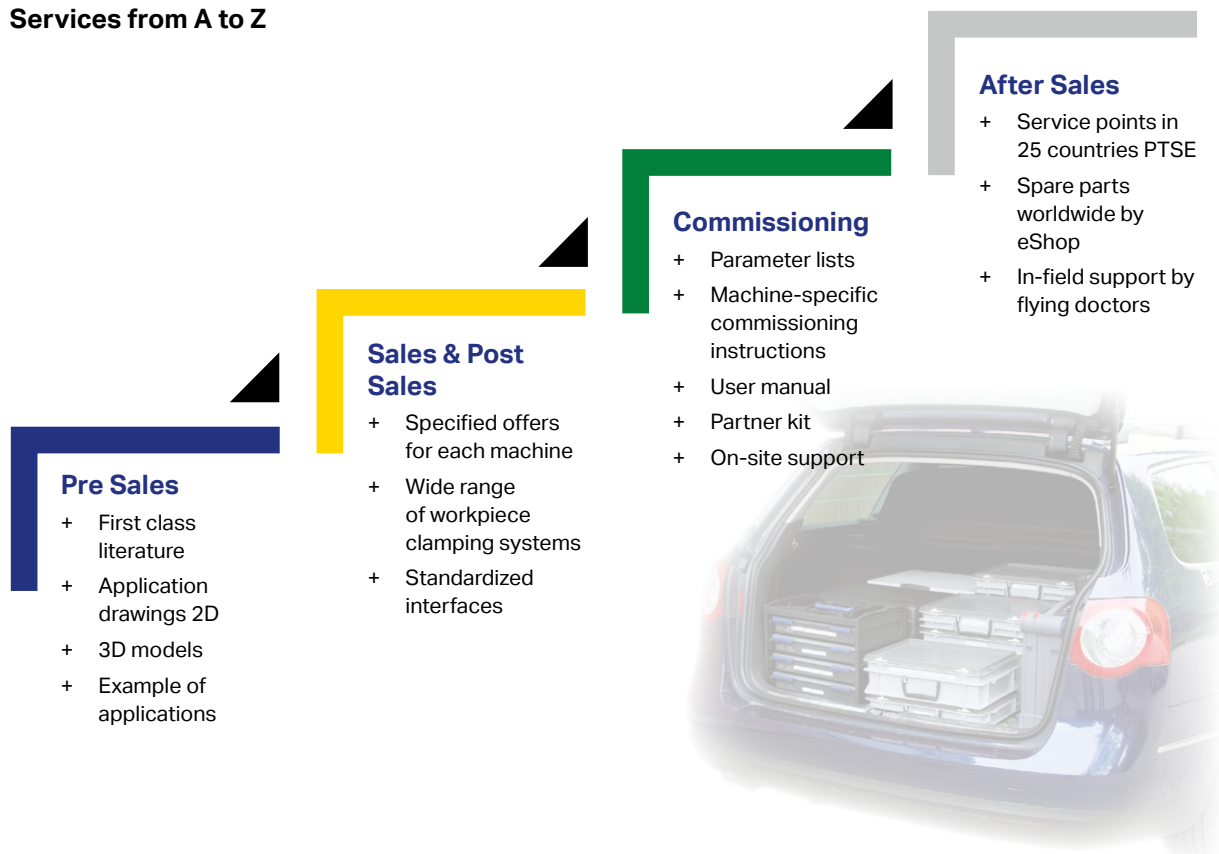



ROTARY TABLES · PRECISION TECHNOLOGY · SOFTWARE

### Headquarters

PETER LEHMANN AG  
Bäraustrasse 43  
CH-3552 Bärau  
Phone +41 (0)34 409 66 66  
Fax +41 (0)34 409 66 00  
sales@plehmann.com  
www.lehmann-rotary-tables.com

### Global network

#### Europe

- Austria
- Benelux
- Czech Republic
- Denmark
- Finland
- France
- Germany
- Hungary
- Ireland
- Italy
- Norway
- Poland
- Portugal
- Russia
- Slovenia
- Spain
- Sweden
- Turkey
- UK

#### America

- Brazil
- Canada
- Mexico
- USA

#### Asia

- China
- India
- Japan
- Malaysia
- Singapore
- South Korea
- Taiwan
- Thailand
- Vietnam



● Headquarters ● direct sales/service partner ● pL SOLUTIONS® partner ● value added reseller & partner

More information (address, telephone number...) at [www.lehmann-rotary-tables.com](http://www.lehmann-rotary-tables.com)