

microCLAMP

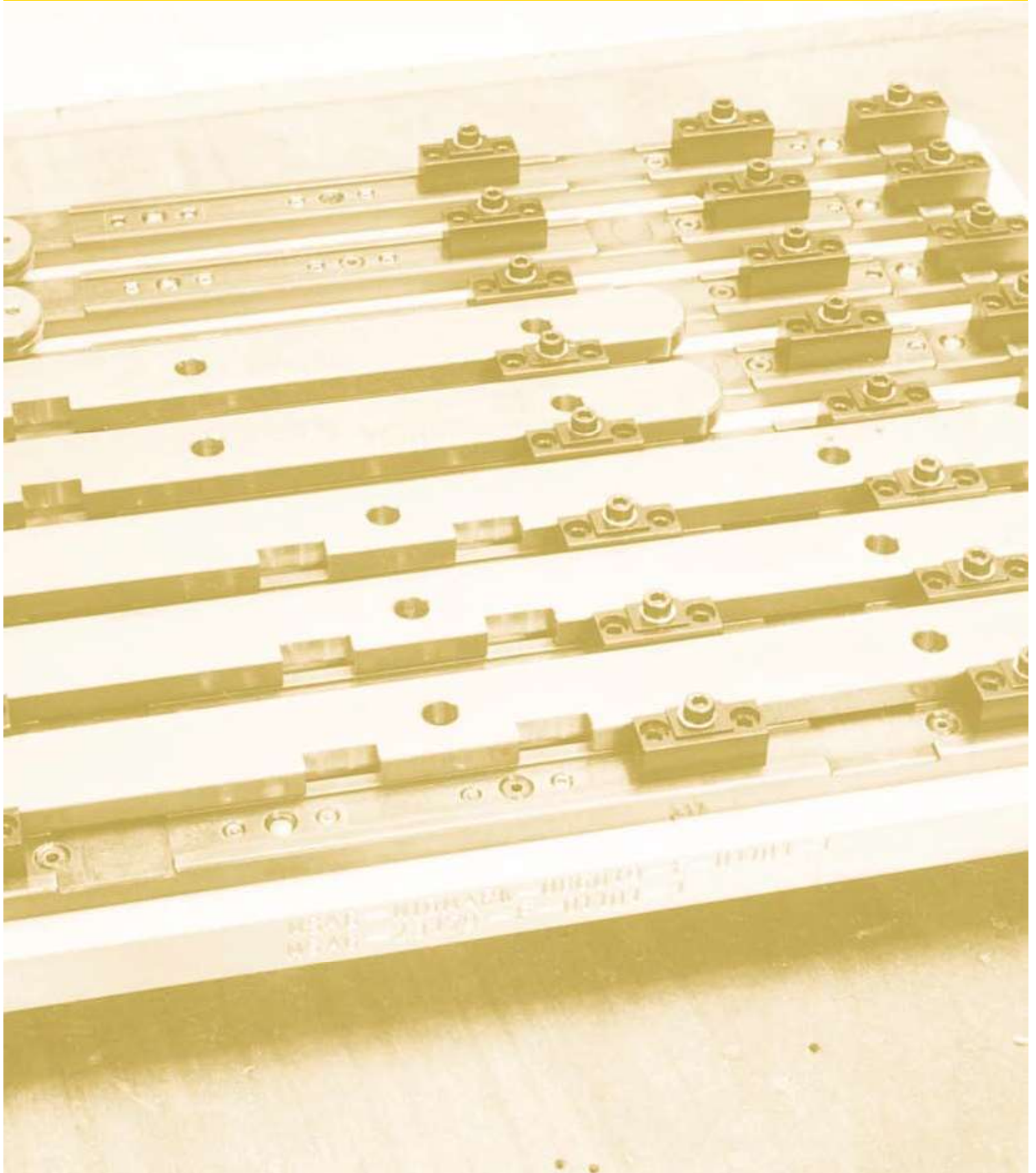

compactCLAMP

Mehrfachspannsystem / Multiple workholding system

**Nur noch Ersatzteile und
Nachlieferungen!
Keine Compact Clamp
Neuentwicklungen mehr!**

Beim Compact Clamp lassen sich die Spannmodule auf einer Basisschiene mittels Passstiften massgenau positionieren. Die Schienen sind mit einem Lochraster mit 7,5 mm Teilung, die Spannmodule mit einer 10 mm-Teilung versehen. Dank Anwendung des Nonius-Prinzips entsteht ein kleinstmöglicher Positionierschritt von 2,5 mm. Bei einem Backenhub von 4 mm ist es somit möglich, an jedem beliebigen Punkt der Schiene nullpunktbezogen zu spannen. Ab 20 mm ist die Bearbeitung von drei Seiten möglich. Da das Spannmodul mit vier Schrauben in den T-Nuten verankert wird, ist es sinngemäss auch möglich, an Stelle der Original-Spannmodule individuelle Vorrichtungen und Sonderbacken zu befestigen. Das Compact Clamp Spannsystem ist ein System für Tüftler. Praktisch keine Spannprobleme bleiben damit ungelöst. Dafür sind die Umrüstzeiten etwas länger als beim Power Clamp. Compact Clamp-Basisschienen sind in den Längen 113 - 750 mm lieferbar. Die angebotenen Befestigungsrastrer sind 40 und 50 mm. Neben den Stahlschienen werden für leichte Arbeiten auch Schienen aus Aluminium hergestellt.

**Only spare parts and
additional deliveries! No
more new Compact Clamp
developments!**

In the Compact Clamp, the vise modules are positioned precisely on a base rail by means of alignment pins. On the base rail, positioning holes are located on a 7,5 mm grid, while on the vise module there is one with a 10 mm spacing. Following the vernier principle, the smallest possible positioning step is therefore 2,5 mm. With a jaw movement of 4 mm it is therefore possible to clamp the workpiece in any desired position with a known distance to program Zero (original datum face). From 20 mm up, three sided machining is possible. Special jaws or dedicated fixtures may easily be bolted onto the rails in place of standard vise modules if the need arises. They may be anchored in the T-slots and located by using alignment pins in the positioning holes. Hence the Compact Clamp is the ideal workholding system for "do it yourself" customers. Change over times are longer than with the Power Clamp, though. Available Compact Clamp base rails lengths: 113 - 750 mm. The fastening grids on the rails are 40 and 50 mm. In addition those made of steel we also produce rails made of aluminum for light work.

Sie können den Katalog unter der folgenden Link herunterladen!
You can download the catalogue at the following download link!

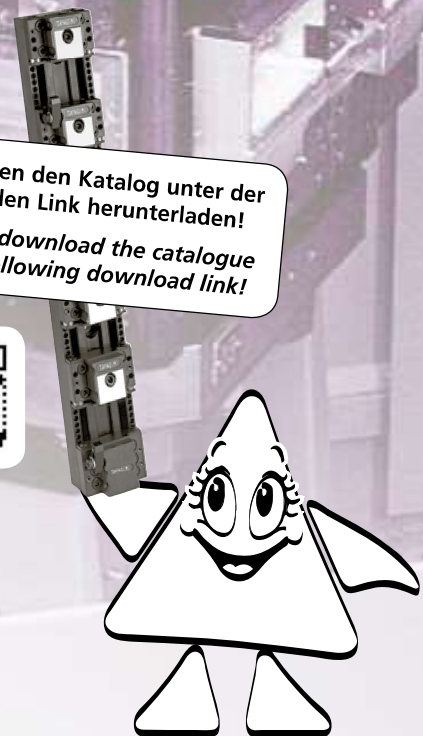



Einleitung | *Introduction* 166 - 167

Anwendungsbeispiele | *Examples of application* 168 - 171



Spannkraft und Drehmoment | *Workholding force and torque* 173

Vorrichtungsbau - Präge- und Anschlagmodule (Linear)
For dedicated fixture - stamping- and end modules (linear) 174 - 176

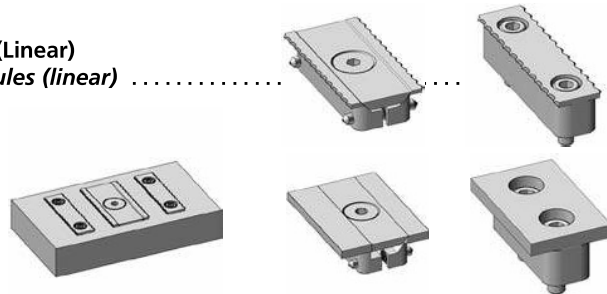

Niederzugspanmodule | *Pull down clamp modules* 177 - 195

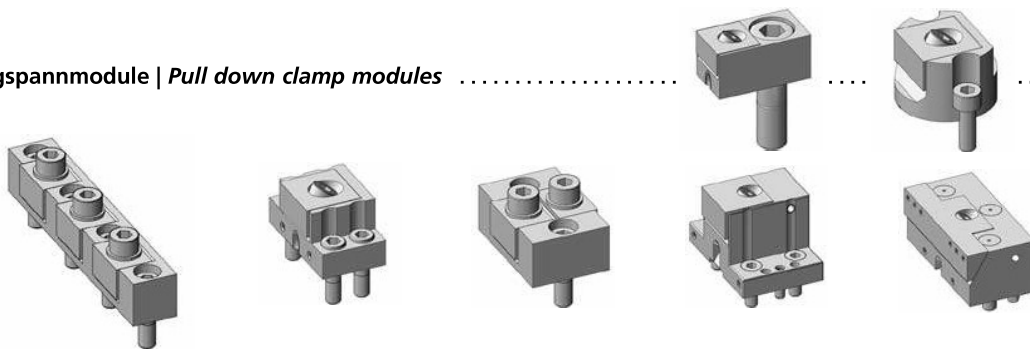

Linearspanmodule | *Linear clamping modules* 196 - 203

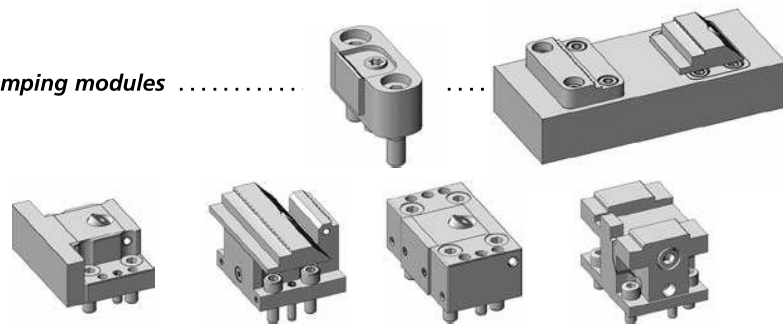

Zubehör | *Accessories* 204 - 205





Zum Aufbau kundenspezifischer Sondervorrichtungen für höchste Werkstückdichte im Arbeitsraum von Bearbeitungszentren ist das Spannsystem Micro Clamp ausgelegt (Spezielle Anschlagbacken, siehe Bild). Sehr kompakte Spannmodule mit Prägebacken verwirklichen eine zuverlässige Aufspannung bei nur etwa 2 mm Verlust an Rohmaterial

Clams for dedicated fixtures for high density to get your best output from your machine. Clamping modules in different sizes and shapes and jaws with serrations also flat and carbide coated are available.

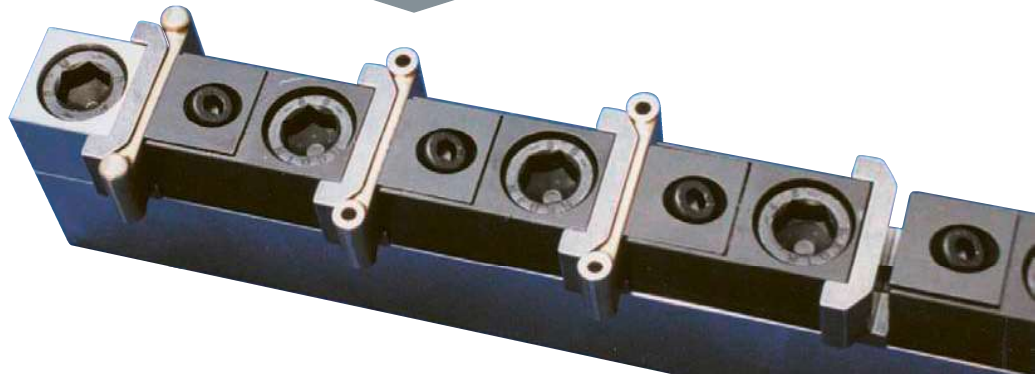

Kleinst-Spannmodule für den Vorrichtungsbau.

Extremely small clamping modules for dedicated fixtures.

Hohe Spanndichte

High workholding density

Die Spannmodule haben auf der Vorderseite eine Spannbacke, die Rückseite ist zu den Befestigungsbohrungen massgenau geschliffen oder gefräst. Damit kann diese Anschlagfläche für das folgende Werkstück genutzt werden. Diese Anordnung lässt eine sehr hohe Spanndichte zu. Beim kleinsten Micro Clamp-Modul sind nur 15 mm Spannabstand erforderlich.

These clamping modules have a clamping jaw on the front, while rear is precisely ground or milled with reference to the fixing holes. This means that it can be used as a datum face for the following workpiece. This arrangement allows very high clamping densities. Only 15 mm clamping clearance is needed between workpieces using the smallest Micro Clamp module.

- Maximale Spannkraft der Module 2,8t (28'000N)
- Benötigter Platz zwischen den Werkstücken ab 15 mm
- Spannhub ab 1,5 mm
- Genaue Positionierung durch Passschrauben und Positionierstifte

- *Clamping force up to 2,8t (28'000N)*
- *Space between workpieces only 15 mm*
- *Stroke of jaw from 1,5 mm*
- *Precise positioning by ground shoulder screws or dowel pins*



Ein grosses Angebot an verschiedensten Spannmodulen.
A wide range of clamp modules in different sizes are available

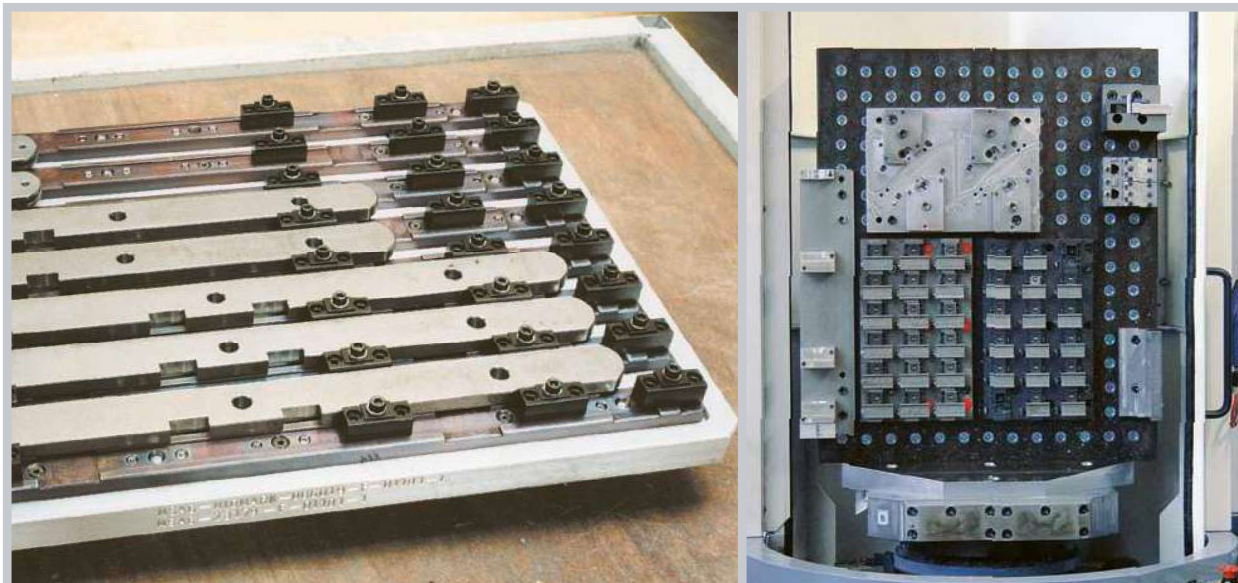

Hohe Spanndichte für Werkstücke in grossen Stückzahlen.
High density fixture plates for repeating orders in high quantities

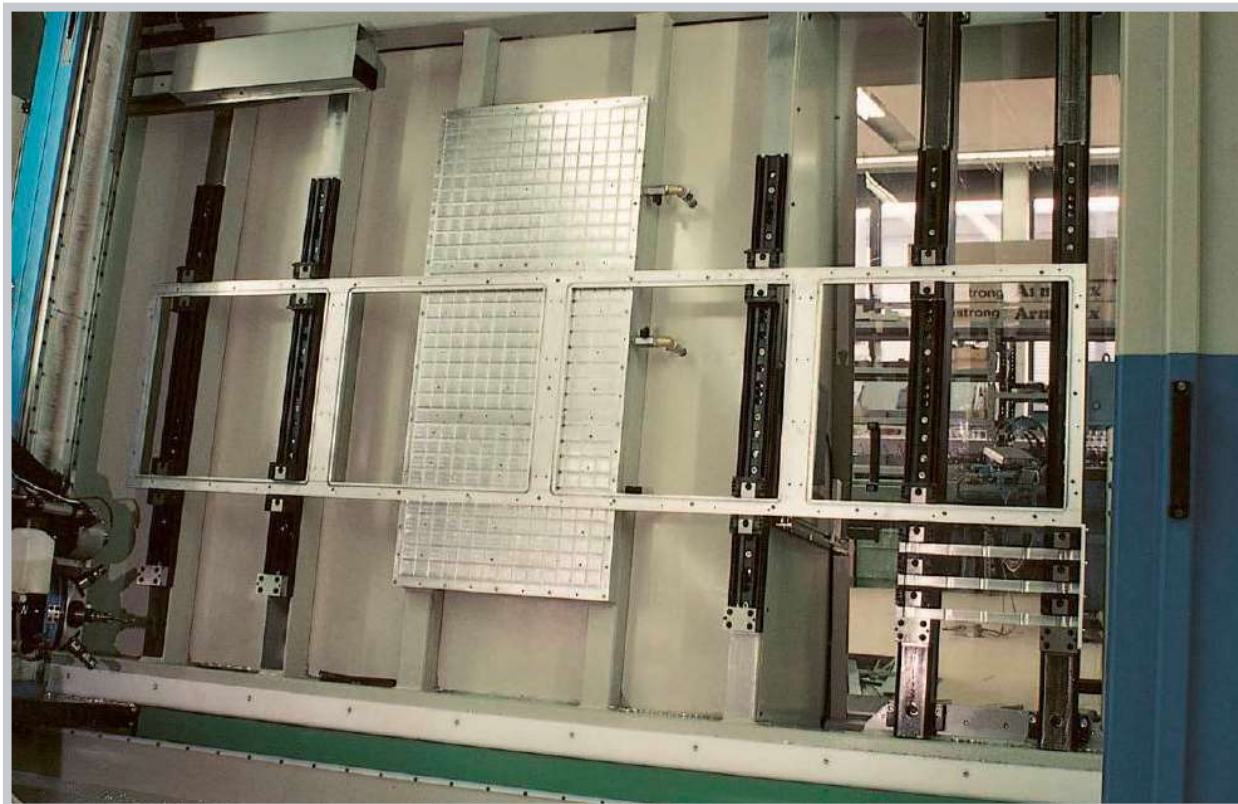

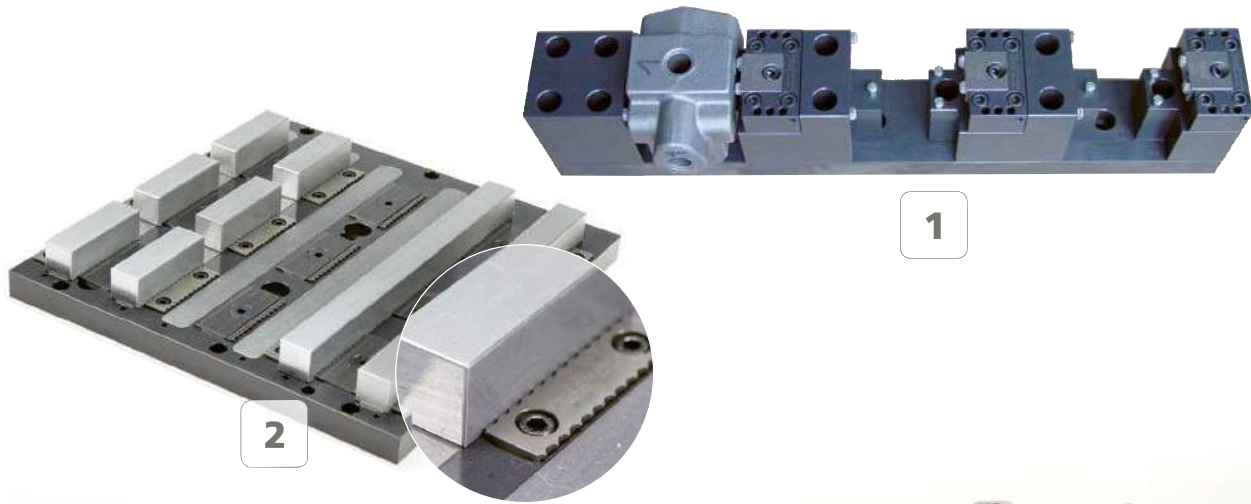

1

2



3

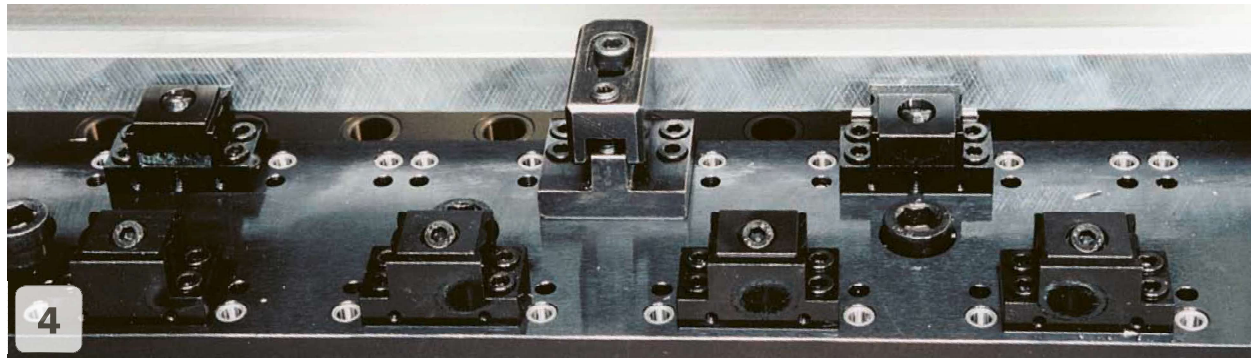

4



5

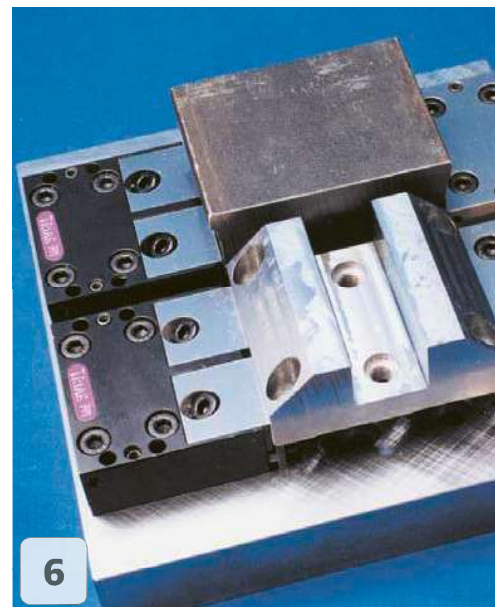

6



7 72 Teile sind hochgenau gespannt unter 10 my. Die Vorrichtungen sind auf einem EROWA ITS O-Punkt Spannsystem aufgebaut
72 parts are clamped within 10 microns the clamp fixtures are set up on a EROWA ITS palleting system

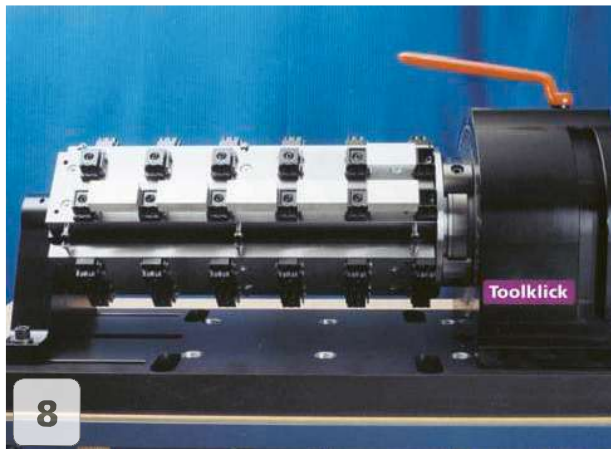

8

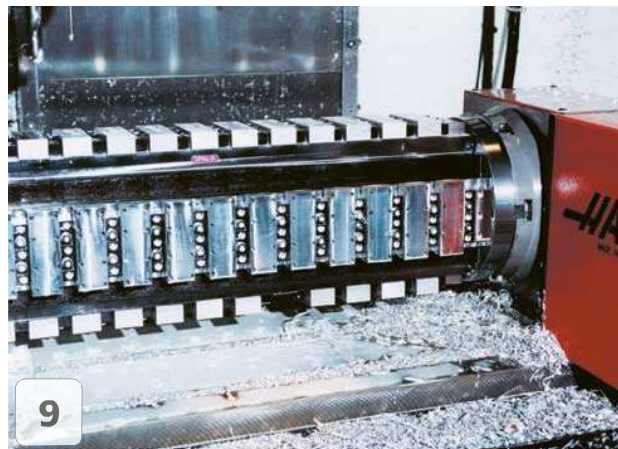

9

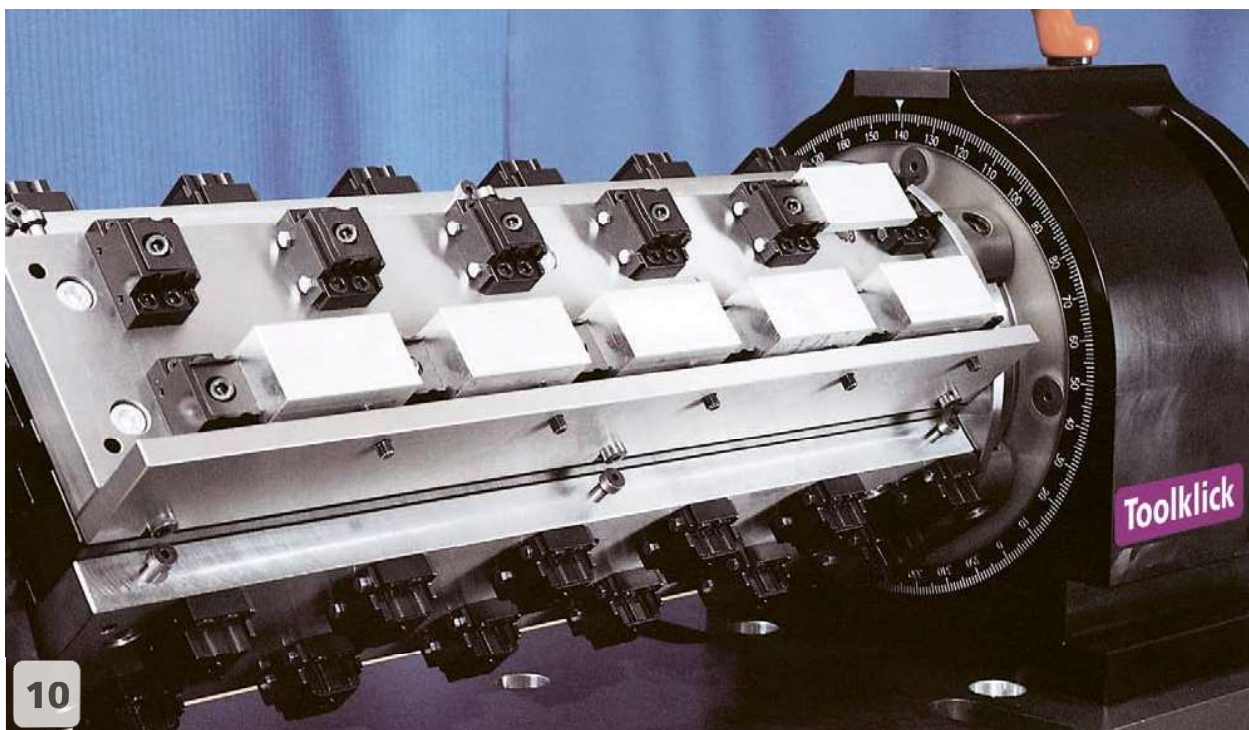

10



11

84 Teile sind gespannt mit Micro Clamp und werden jeweils nachts unbemannt produziert
84 parts are clamped with Micro Clamp and are machined always at night unmanned

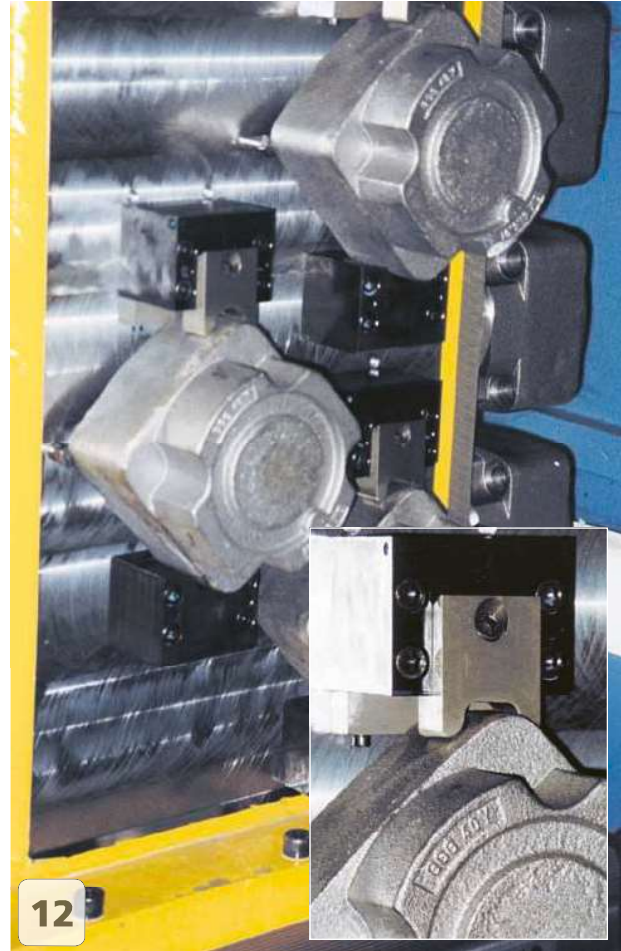

12

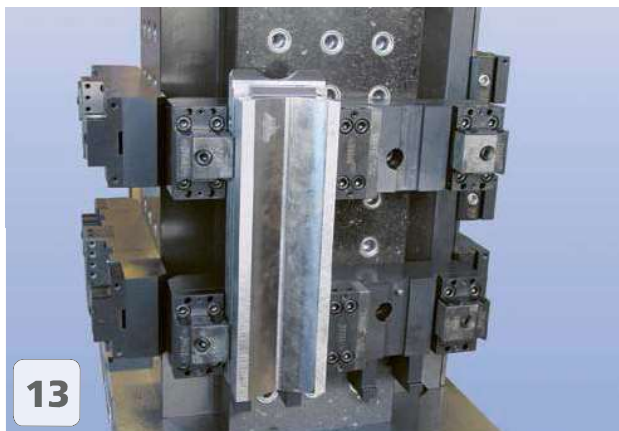

13



16

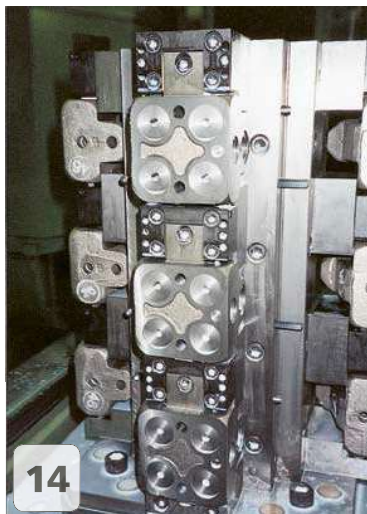

14



15

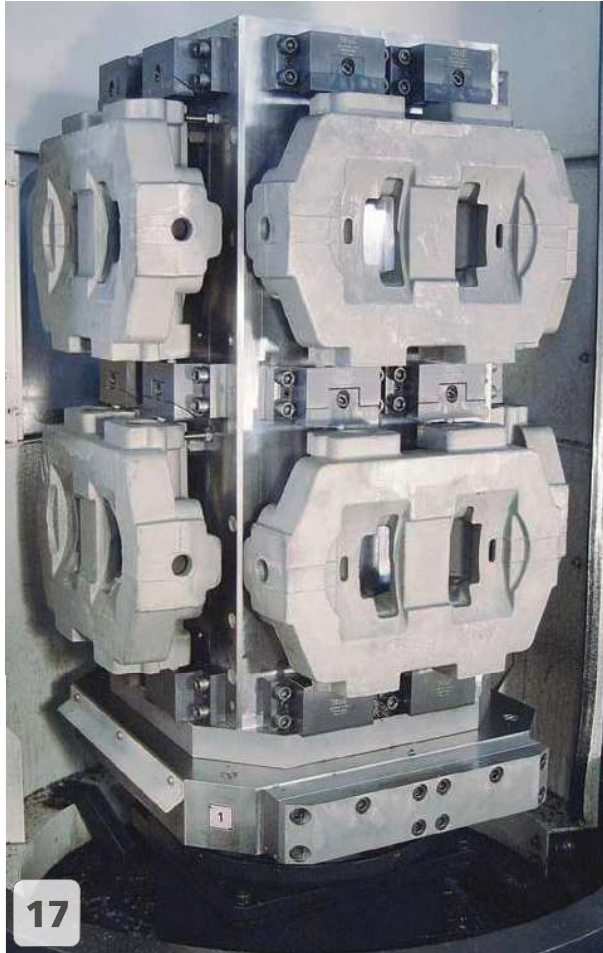

17



18

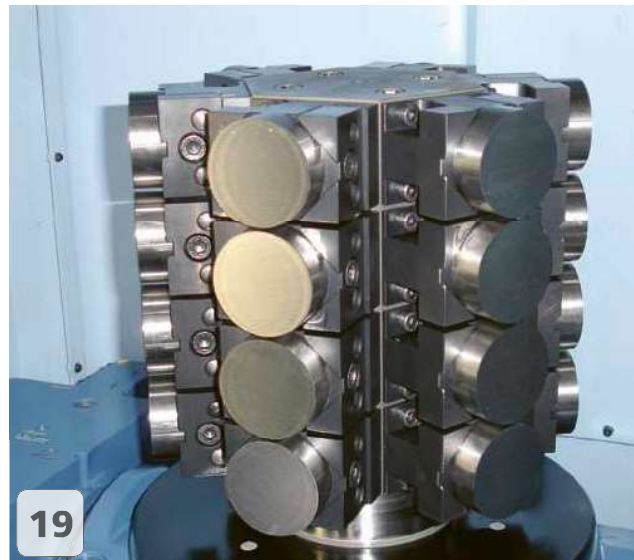

19



20



21



System System		bei Anschlagmodulen for end module		Modulnutzbreite Module clamping width		Modulnutztiefe / -höhe Module clamping depth or height		
A	Apto Clamp	N	nitriert nitrited	19		MS: Tiefe Depth		
P	Power Clamp	D	durchgehärtet through hardened	25				
C	Compact Clamp	bei Spannmodulen for vice modules		26				
M	Micro Clamp	1	Anzahl Spannbacken Number of jaws	34				
V	Vorrichtungsbaumodule Workholding modules for dedicated fixtures	2		-				43
		3						
				58			VS: Höhe Height	
				61				
				68				
				78				
				94				
				125				

M S 1 F 35 N 14 -01

Modultyp Type of module	
A	Anschlagmodul End module
S	Spannmodul Clamping module
T	Trägermodul Supporting module
R	Rohling / Rundes Modul Blank / Round module
V	Vertikalspannmodul Vertical clamp

Anschlagfläche der Module Datum face	
F	Anschlagfläche glatt Datum face flat
R	Anschlagfläche geriffelt Datum face double serrated
D	eine Seite glatt, eine Seite geriffelt one face flat, one face double serrated
G	Anschlagfläche gerillt Datum face serrated
X	spezielle Ausführung special execution
5X	5axes Clamp
P	prägen stamping

Backenhub Stroke of clamping jaw	
N	Niederzug Pull down
L	linear / parallel linear / parallel
-	ohne Spannbacke no clamping jaw

Spannbackentyp Type of clamping jaw	
B01	Spannbacke Clamping jaw
- B151	
-01	Modul ohne Spannbacken Module without clamping jaw
-150	



ACHTUNG / CAUTION

WICHTIG: Die im Micro Clamp Kapitel angegebenen Drehmomente sind die absoluten Maximalwerte. Über die Spannkraften gibt die untenstehende Tabelle Auskunft.

IMPORTANT: The torque numbers specified in the Micro Clamp chapter represent the absolute maximum. The table at the bottom of this page provides further information on the workholding forces.

Niederzug-Spannmodule Pull down module	MC-Module	Schraube Screw	Drehmoment Torque		Spannkraft Workholding force			
			Nm	(lb-ft)	~daN	~(lb)	~t	
	MR1F 30N23 -07	M5	10	7,4	= 1020	2250	1,02	
	MS1F 22N40 -07		10	7,4	= 1020	2250	1,02	
	MS1F 24N22 -07		10	7,4	= 1020	2250	1,02	
	MS1R/F 25N25 -13	M6	15	11	= 1520	3350	1,52	
	MS1F 35N14 -01		10	7,4	= 1020	2250	1,02	
	MS1F 35N22 -01	M5	10	7,4	= 1020	2250	1,02	
	MS2X 25N23 -01		10	7,4	= 1020	2250	1,02	
	MS2F 60N14 -01		10	7,4	= 1020	2250	1,02	
	MS3F 85N14 -01		10	7,4	= 1020	2250	1,02	
	VS1R 19N35 -20		M6	15	11	= 1520	3350	1,52
	VS1R 26N35 -26	25		18,4	= 2100	4630	2,10	
	VS1R 38N50 -60	25		18,4	= 2100	4630	2,10	
	VS1R/F 41N30 -60	25		18,4	= 2100	4630	2,10	
	VS1R/F 80N30 -36	M8		25	18,4	= 2100	4630	2,10
	VS1R 80N50 -36			25	18,4	= 2100	4630	2,10
	VS1R/F 80N30 -60			25	18,4	= 2100	4630	2,10
	VS1R 80N50 -60			25	18,4	= 2100	4630	2,10
	VS1R/F 125N49 -95	M10	40	29,5	= 2800	6170	2,80	
VS2R 80N30 -60	25		18,4	= 2100	4630	2,10		
VS2F 90N30 -60	25		18,4	= 2100	4630	2,10		
VS2F 90N30 -60	25		18,4	= 2100	4630	2,10		
Linear-Spannmodule Linear module 	MS1F (MS1R) 35L14 -152	M6x0,5	10	7,4	= 570	1260	0,57	
	MS2P (MS2P) 58L14 PRG15	M8	15	11	= 600	1320	0,6	
	MS2F (MS1F) 58L14 W251		15	11	= 600	1320	0,6	
	VS1R 26L35 -31		25	18,4	= 2100	4630	2,10	
	VS1R/F 41L30 -51		25	18,4	= 2100	4630	2,10	
	VS1R/F 80L30 -51		25	18,4	= 2100	4630	2,10	
	VS1X 68L20 -105		40	29,6	= 1600	3530	1,60	
	VS1X 59L60 K		M10	50	37	= 1880	4140	1,88
	VS1X 59L60 H5	50		37	= 1640	3620	1,64	

Die Spannbacken und Schrauben regelmässig fetten!

Lubricate clamping jaw and screw regularly with grease!

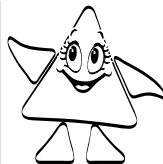

Schraube Screw	Drehmoment Torque		Spannkraft Workholding force			
M5 + M6	4	3	= 500	1100	0,50	
	5	3,7	= 580	1280	0,58	
	6	4,4	= 690	1520	0,69	
	7	5,2	= 780	1720	0,78	
	8	5,9	= 880	1940	0,88	
	9	6,6	= 980	2160	0,98	
M6	10	7,4	= 1020	2250	1,02	
	12	8,9	= 1220	2690	1,22	
	14	10,4	= 1450	3200	1,45	
	15	11	= 1520	3350	1,52	
	M8	4	3	= 410	900	0,41
		5	3,7	= 490	1080	0,49
6		4,4	= 560	1250	0,56	
7		5,2	= 660	1460	0,66	
8		5,9	= 730	1610	0,73	
9		6,6	= 810	1790	0,81	
10		7,4	= 900	1980	0,90	
M10	15	11	= 1520	3350	1,52	
	20	14,8	= 1810	3990	1,81	
	25	18,4	= 2100	4630	2,10	
	10	7,4	= 400	880	0,40	
	20	14,8	= 1400	3090	1,40	
	30	22,1	= 2000	4410	2,00	
40	29,5	= 2800	6170	2,80		



Keilspanner in weicher Ausführung zum Bearbeiten von Formbacken.

Double angle clamps with soft jaws for making shaped forms.

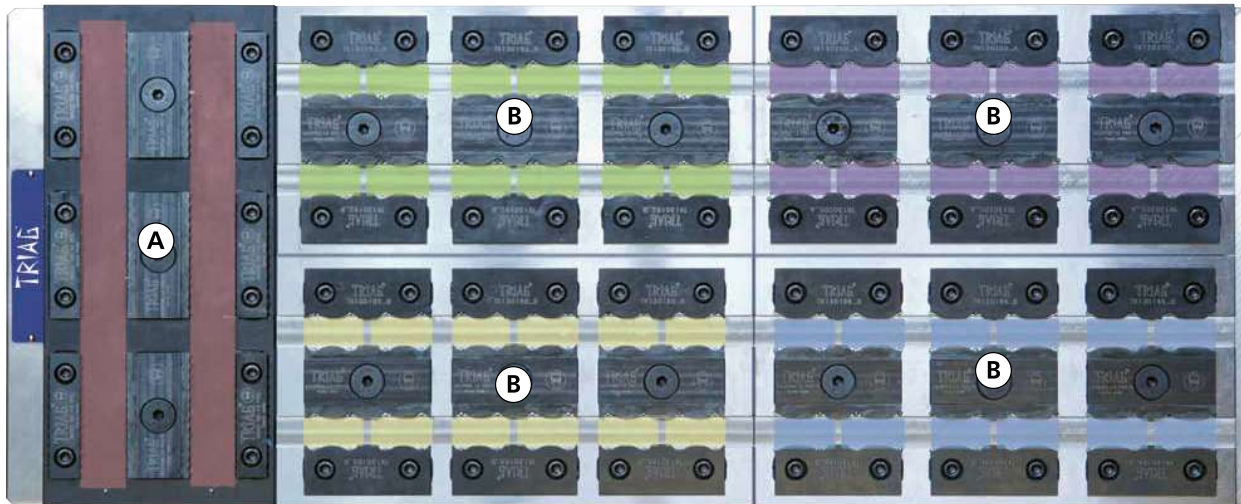

A Prägebacken Spanntiefe 1,8 mm
 12 Werkstücke werden hergestellt
*First clamp 12 parts with stamping jaws
 clamping depth 1,8 mm*

B 4 x 12 verschiedene Teile werden in der
 2. Spannung bearbeitet
*4 times 12 different parts are machined
 in the second operation*

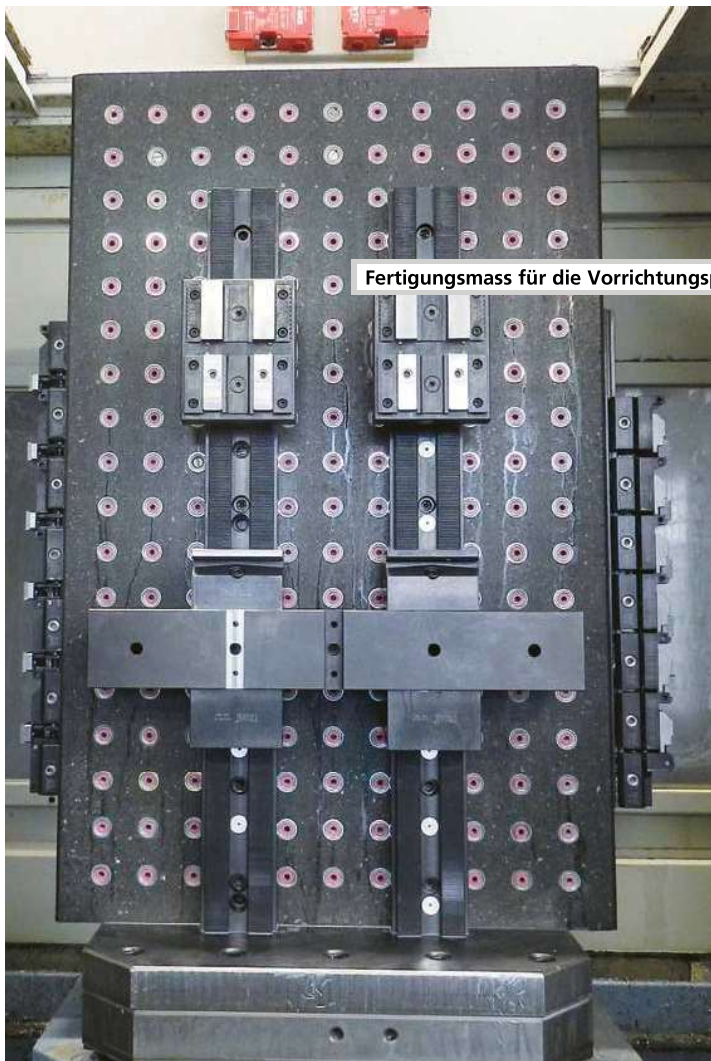

Fertigungsmass für die Vorrichtungsplatte: / Machining data for the fixture plate: p. 175

Fräser / Milling cutter

Der abgebildete Fräser benötigt man für die Herstellung der «Kerben».
 Siehe Fertigungsmasse für die Vorrichtungsplatte Seite 175.

*The illustrated milling cutter is required for the production of "notches".
 Manufacturing drawing for the fixture plate on page 175.*

45°	d	D	L1	H	z	L
TK150057	6	6,0	24,0	1,5	3	58

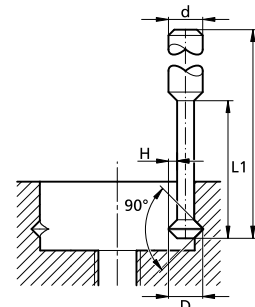

Fertigungsmasse für die Vorrichtungplatte / Maching data for the fixture plate

<p>Mass X (X1) = B + 24 mm Beispiel: Bauteilbreite = 14 mm</p> <p>Dimension X (X1) = B + 24 mm Example: Width of component part = 14 mm</p> <p>Taschenabstand X = 14 + 24 = 38 Das ergibt eine Einlegeluft von 0,8 mm (Hub bis 2,7 mm)</p>	<p>Mass X2 = B + 33,5 mm Beispiel: Bauteilbreite = 14 mm</p> <p>Dimension X2 = B + 33,5 mm Example: Width of component part = 14 mm</p> <p>Taschenabstand X = 14 + 33,5 = 47,5 Das ergibt eine Einlegeluft von 0,8 mm (Hub bis 2,7 mm)</p>

Hub bis / Stroke till = 2,7 mm

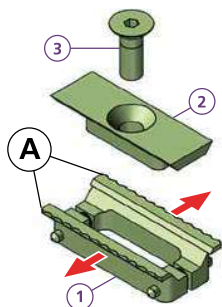
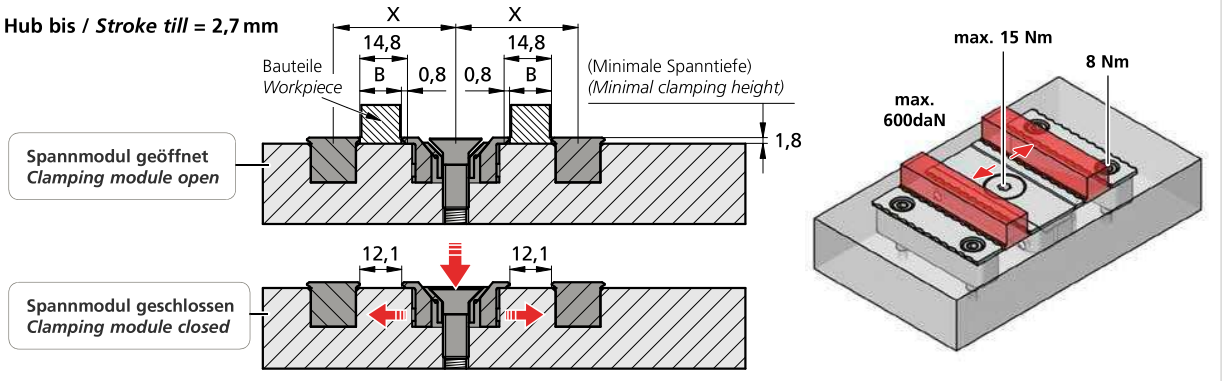

MS2P58L14PRG15

- 1 2x TK120225
- 2 1x TK120227
- 3 1x M8X22DIN7991

Y 4,7 mm
i 57HRC
kg ~0,12

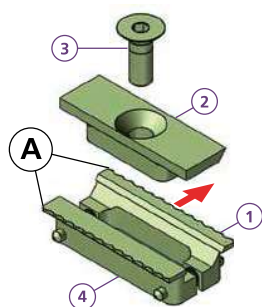

MS1P58L14PRG15

- 1 1x TK120225
- 2 1x TK120721
- 3 1x M8X22DIN7991
- 4 1x TK120720

Y 4,7 mm
i 57HRC
kg ~0,12

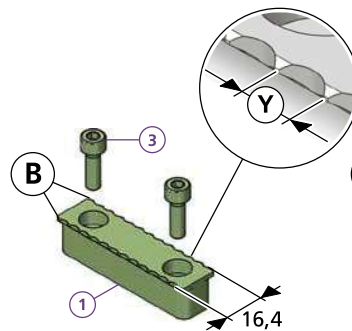

MAND58-14PRG

- 1 1x TK120226
- 3 2x M5X16ISO4762

Y 4,7 mm
i 57HRC
kg ~0,08

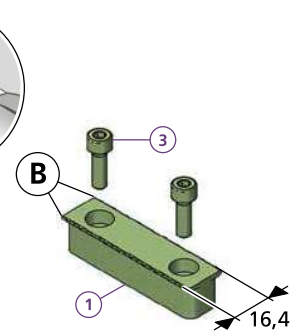

MAND58-14PRG6

- 1 1x TB150282
- 3 2x M5X16ISO4762

Y 6,0 mm
i 57HRC
kg ~0,08

Zum Erstellen Ihrer individuellen Formbacke:
 Schnittzeichnung zum Ermitteln der maximalen
 Bearbeitungsprofiltiefe
If a dedicated jaw is being machined:
 Sectional drawing to determine the maximum
 machining depth

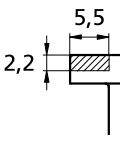

für / for TK120531 | TK120531 | TK120529 | TK160554

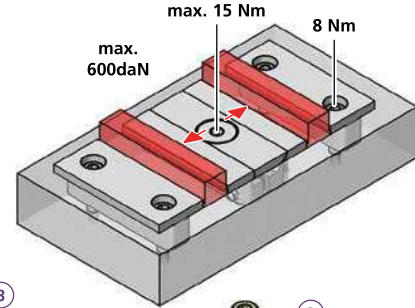
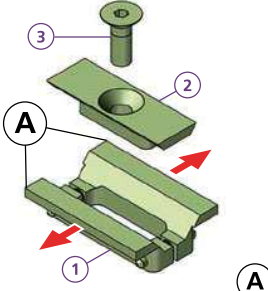



MS2F58L14W251

- 1 2x TK120531
- 2 1x TK120227
- 3 1x M8X22DIN7991

i *

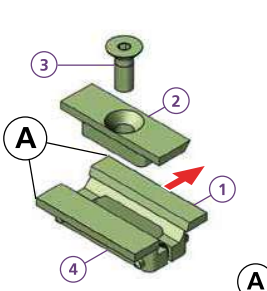
kg ~-0,12



MS1F58L14W251

- 1 1x TK120531
- 2 1x TK120721
- 3 1x M8X22DIN7991
- 4 1x TH130566

i *

kg ~-0,12

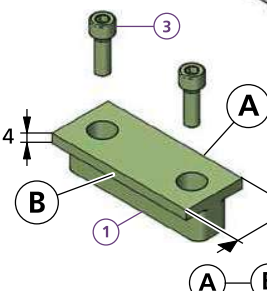

MANF58-14W25

- 1 1x TK120529
- 3 2x M5X16ISO4762

i *

MANF58-14F25

- 1 1x TK150033
- 3 2x M5X16ISO4762

i HV700 x 0,2mm

kg ~-0,11

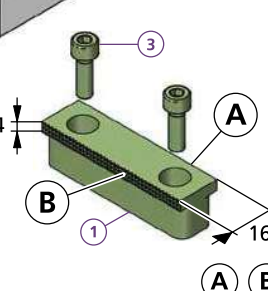

MANF58-14RF

- 1 1x TB160563
- 3 2x M5X16ISO4762

i HV700 x 0,2mm

kg ~-0,11

p. 175 Fertigungsmass für die Vorrichtungplatte / Machining data for the fixture plate:

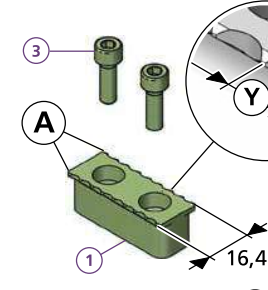

MAND38-14PRG

- 1 1x TB150234
- 3 2x M5X16ISO4762
- Y 4,7 mm

i 57HRC

kg ~-0,08

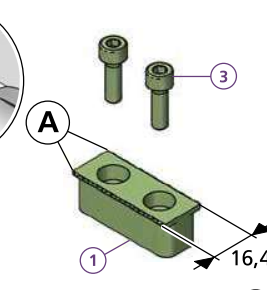

MAND38-14PRG6

- 1 1x TB150283
- 3 2x M5X16ISO4762
- Y 6,0 mm

i 57HRC

kg ~-0,08

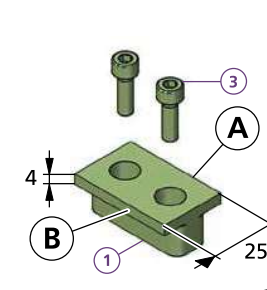

MANF38-14W25

- 1 1x TK160554
- 3 2x M5X16ISO4762

i *

MANF38-14F25

- 1 1x TK160553
- 3 2x M5X16ISO4762

i HV700 x 0,2mm

kg ~-0,08

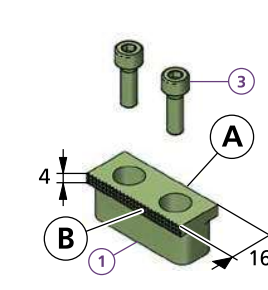

MANF38-14RF

- 1 1x TB170062
- 3 2x M5X16ISO4762

i HV700 x 0,2mm

kg ~-0,08

Fertigungsmass für die Vorrichtungplatte
Machining data for the fixture plate

für / for TB150234 | TB150283 | TK160554 | TK160553 | TB170062

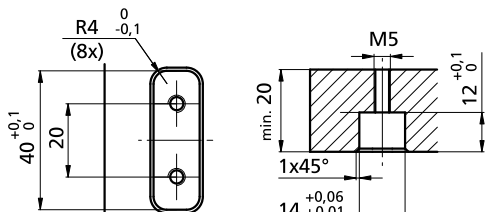

Spannmodule

Clamping module MV1F20L35BV1



microCLAMP

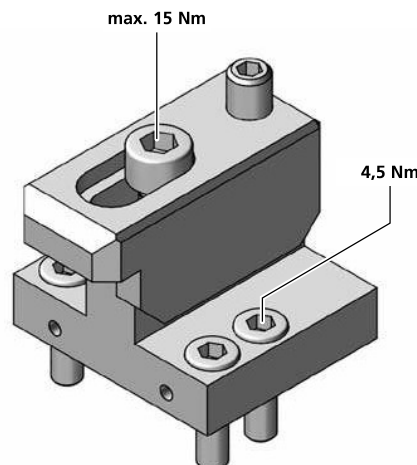
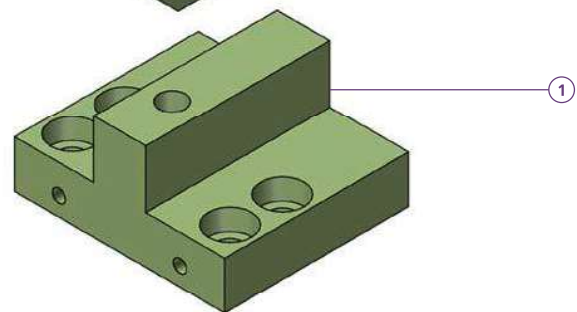
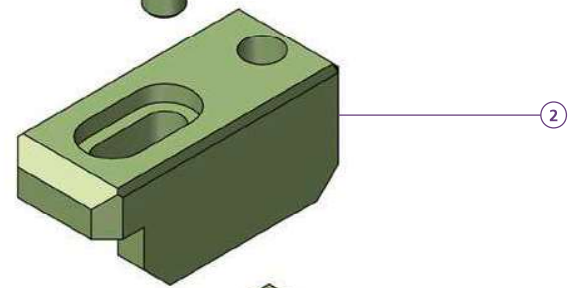
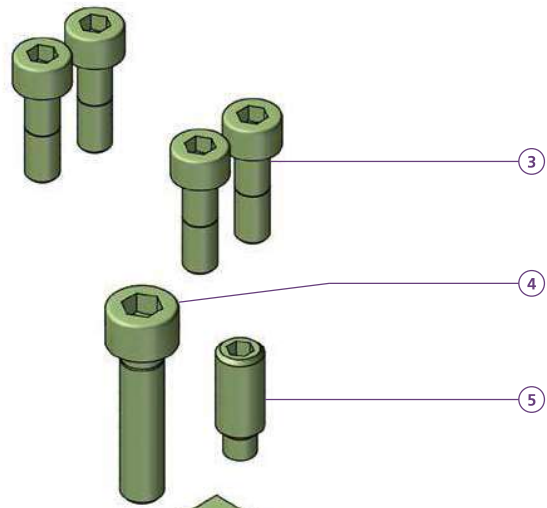
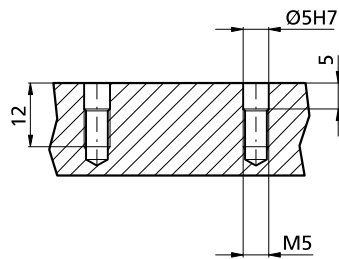
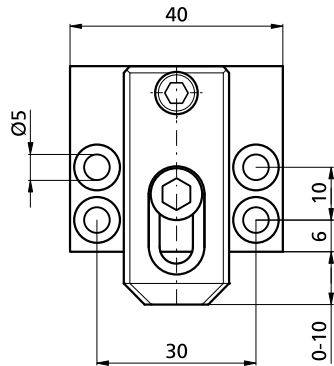
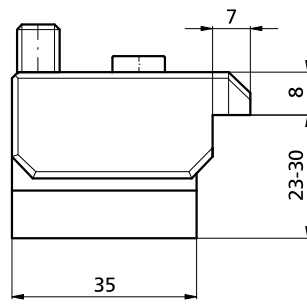
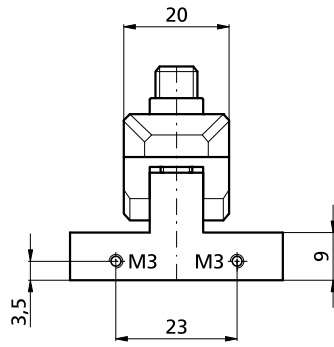

MV1F20L35BV1	
①	1x TF140710
②	1x BV1
③	4x M550
④	1x M6X25ISO4762
⑤	1x M8x20ISO4028
kg	~0,225

Bestellbeispiel / Ordering example : MV1F20L35BV1

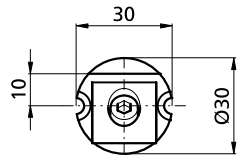
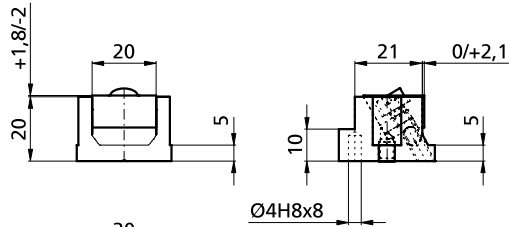
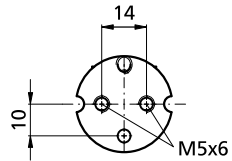

Version 2

Version 1

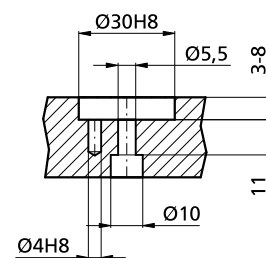
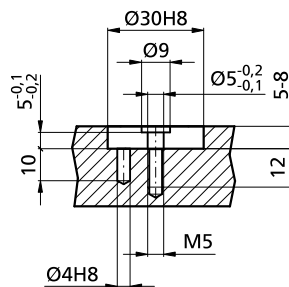
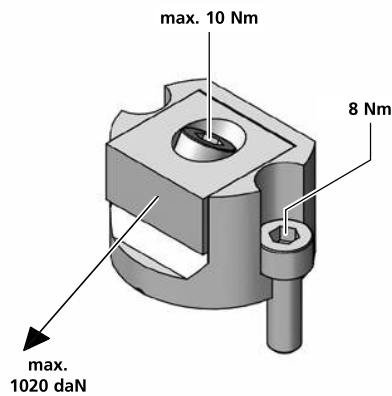
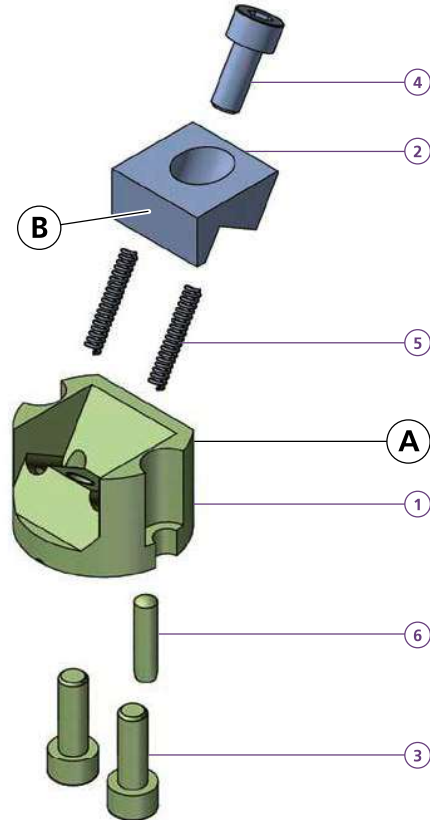
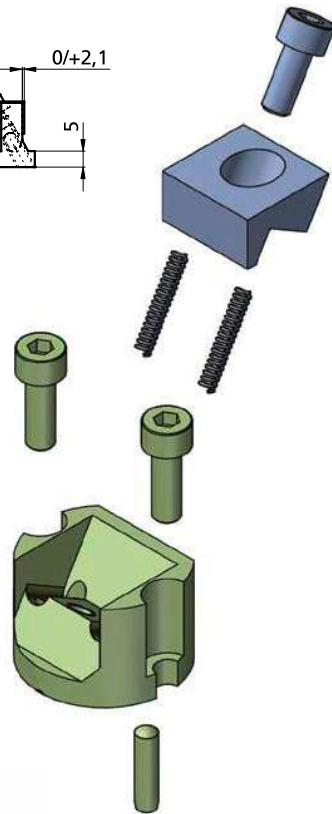

Bestellbeispiel / Ordering example: 1x MR1F30N23-07 & 1x B08

MR1F30N23-07	
1	1x TF140711
2	1x
3	2x M5X16ISO4762
4	1x M5X12ISO4762
5	2x FED03018
6	1x Ø4x14 DIN 6325
kg	~0,095

	B07	B08	B09	B09+2	B09+5
C	20	20	20	20	20
H	10	10	10	10	10
L	9,5	9,5	9,5	11,5	14,5
D	5,5	5,5	5,5	5,5	5,5
ø	6	6	6	6	6
i	HV700 x0,2mm	HV700 x0,2mm	*	*	*
kg	~0,02	~0,02	~0,02	~0,02	~0,02

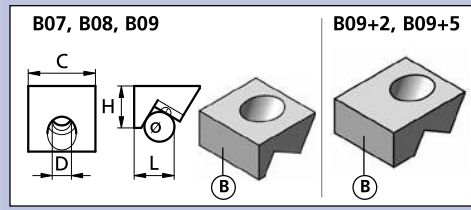

Separat bestellen / Separate order



MS1F22N40-07

microCLAMP

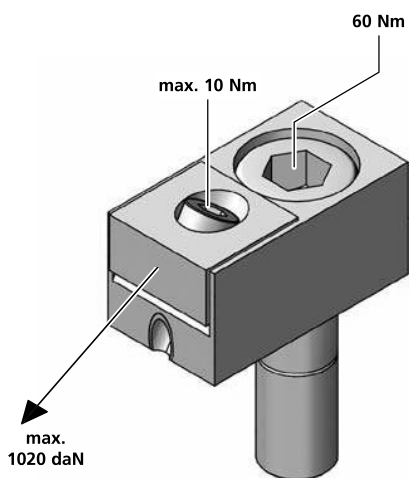
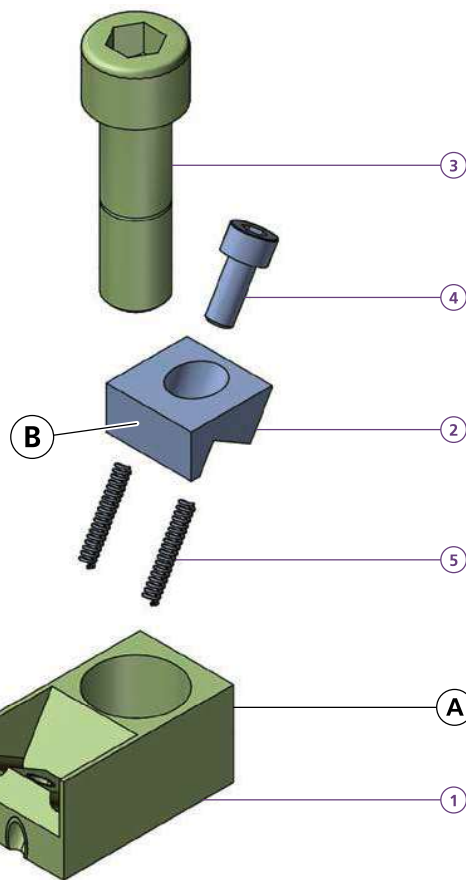
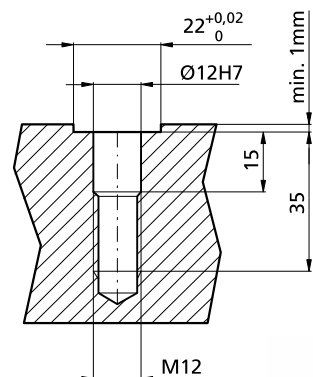
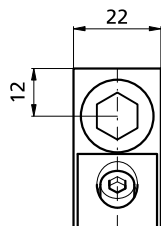
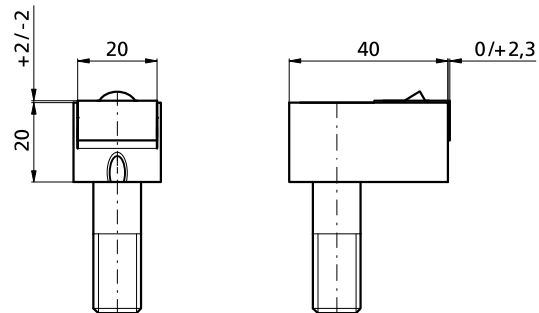

MS1F22N40-07	
1	1x TF140712
2	1x
3	1x TWPAS1240
4	1x M5X12ISO4762
5	2x FED03018
kg	~0,15

	B07	B08	B09	B09+2	B09+5
C	20	20	20	20	20
H	10	10	10	10	10
L	9,5	9,5	9,5	11,5	14,5
D	5,5	5,5	5,5	5,5	5,5
ø	6	6	6	6	6
i	HV700 x0,2mm	HV700 x0,2mm	*	*	*
kg	~0,02	~0,02	~0,02	~0,02	~0,02

Bestellbeispiel / Ordering example: 1x MS1F22N40-07 & 1x B08

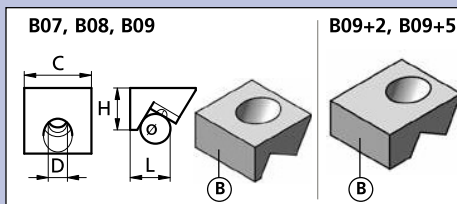

* = weicher Stahl / soft steel

Separat bestellen / Separate order



MS1R/F24N22-07

microCLAMP

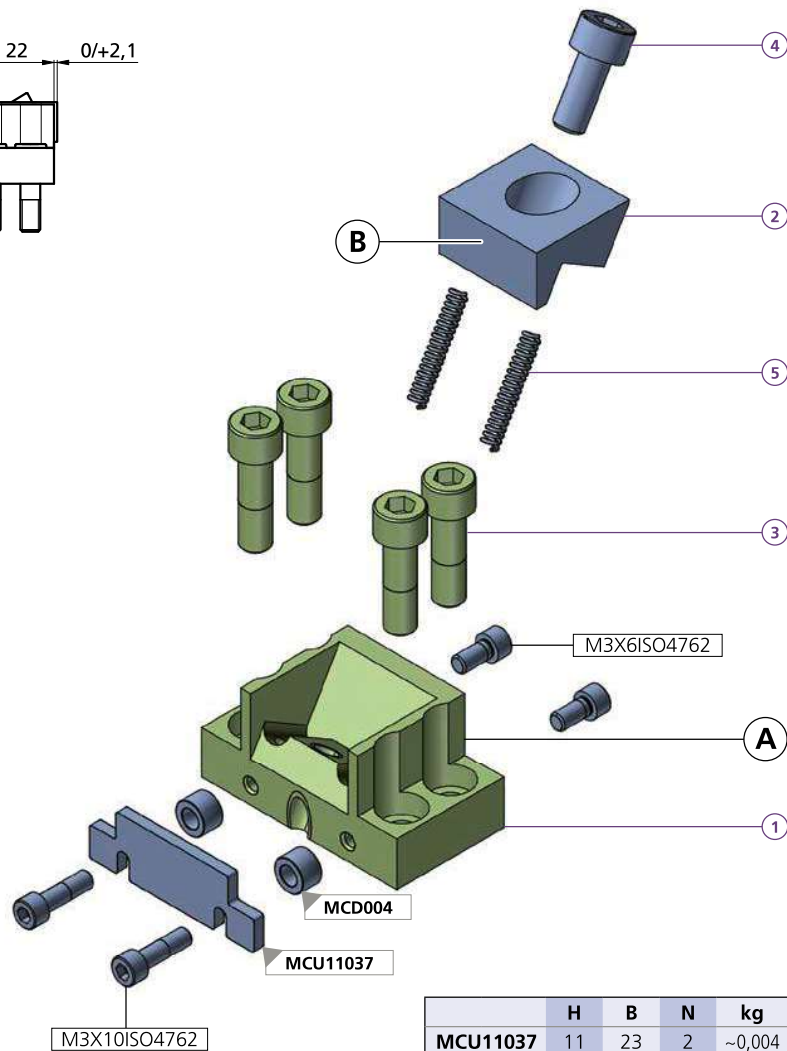
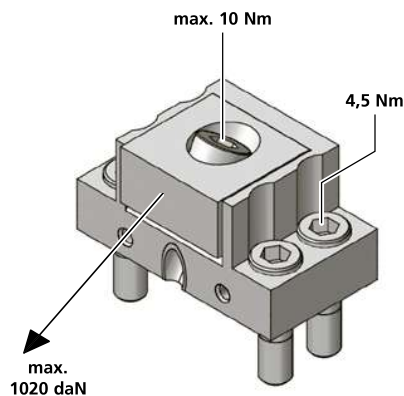
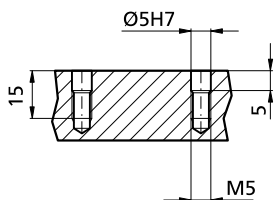
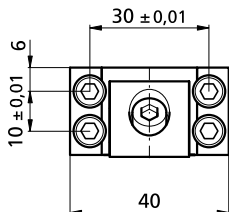
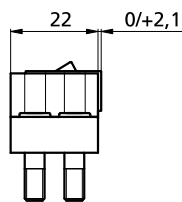
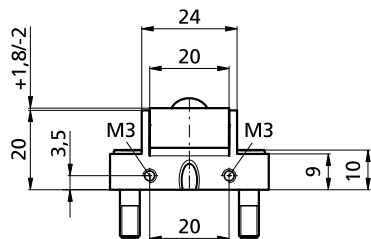

	H	B	N	kg
MCU11037	11	23	2	~0,004
MCU15037	15	23	2	~0,006
MCU18037	18	23	2	~0,008
MCU20037	20	23	2	~0,008
MCU22537	22,5	23	2	~0,008

- 2x M3X10ISO4762
- 2x M3X6ISO4762
- 2x MCD004

Achtung: Bei Spannkraften über 400 daN (0,4t) muss das Spannmodul in eine Nut eingelassen werden (Nuttiefe mindestens 1mm)

Remark: Using forces higher than 400 daN, clamps must be mounted into a slot (depth minimum 1mm)

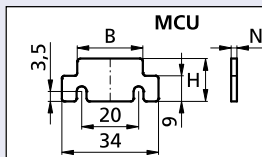
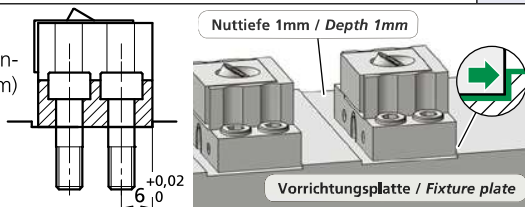

MS1F24N22-07	
1x TF140713	
MS1R24N22-07	
1x TW100172-01	
1x	
4x MS50	
1x M5X12ISO4762	
2x FED03018	
kg	~0,125

	B07	B08	B09	B09+2	B09+5
C	20	20	20	20	20
H	10	10	10	10	10
L	9,5	9,5	9,5	11,5	14,5
D	5,5	5,5	5,5	5,5	5,5
ø	6	6	6	6	6
i	HV700 x0,2mm	HV700 x0,2mm	*	*	*
kg	~0,02	~0,02	~0,02	~0,02	~0,02

Bestellbeispiel / Ordering example: 1x MS1F24N22-07 & 1x B08

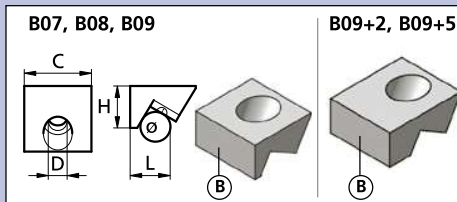

Separat bestellen / Separate order



MS1R/F25N25-13

microCLAMP

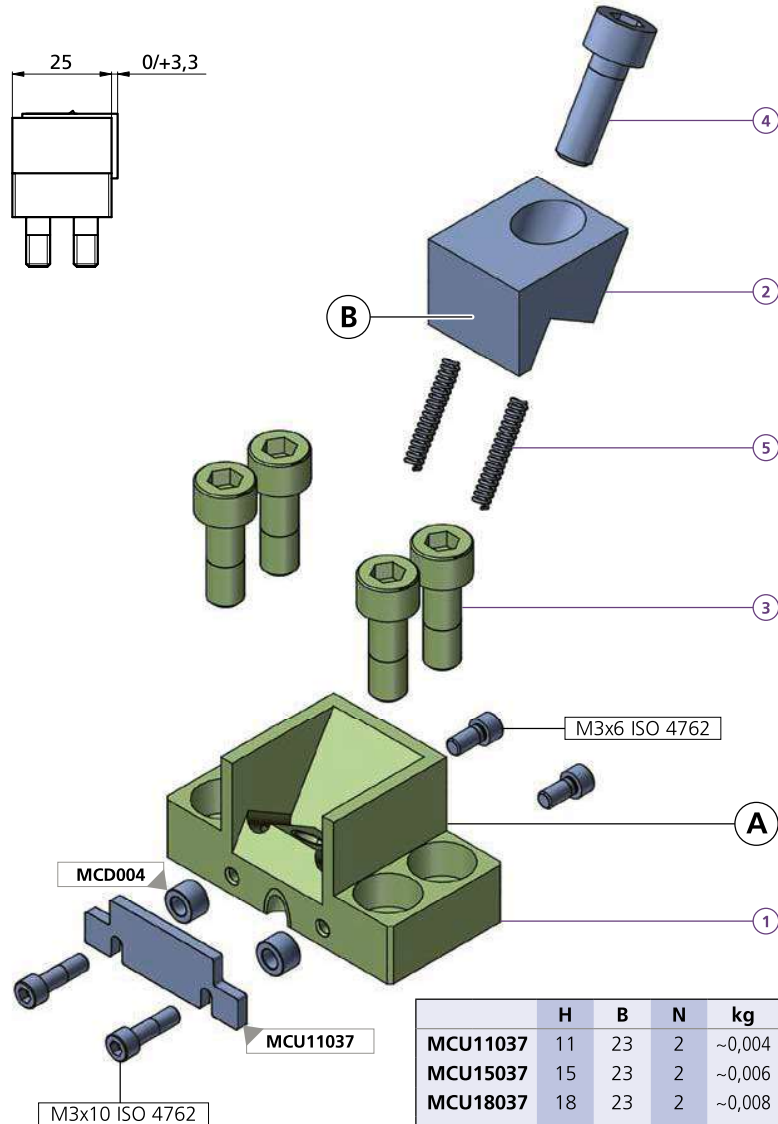
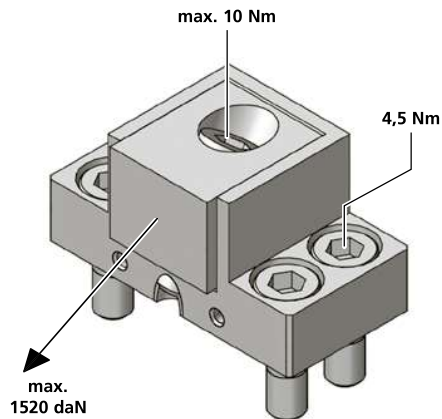
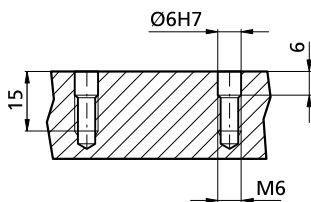
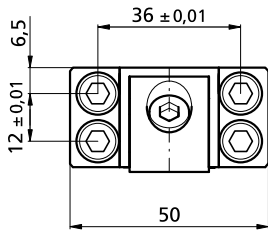
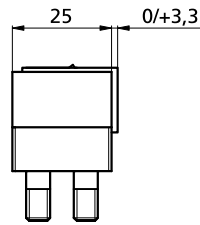
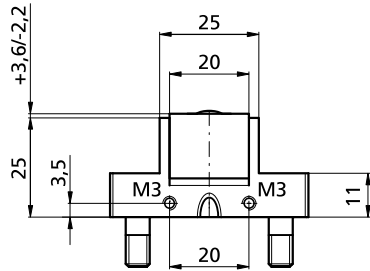

	H	B	N	kg
MCU11037	11	23	2	~0,004
MCU15037	15	23	2	~0,006
MCU18037	18	23	2	~0,008
MCU20037	20	23	2	~0,008
MCU22537	22,5	23	2	~0,008

- 2x M3X10ISO4762
- 2x M3X6ISO4762
- 2x MCD004

Achtung: Bei Spannkraften über 400 daN (0,4t) muss das Spannmodul in eine Nut eingelassen werden (Nuttiefe mindestens 1mm)

Remark: Using forces higher than 400 daN, clamps must be mounted into a slot (depth minimum 1mm)

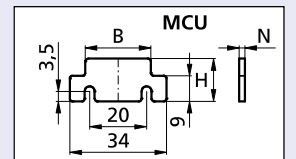
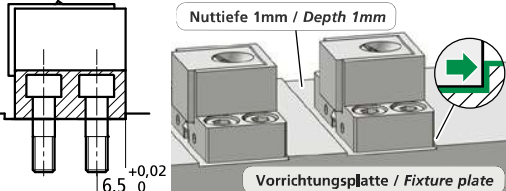

MS1F25N25-13	
1	1x TF140714
MS1R25N25-13	
1	1x TF140715
2	1x
3	4x MS60
4	1x M6X16ISO4762
5	2x FED03018
kg	~0,165

Bestellbeispiel / Ordering example: 1x MS1F25N25-13 & 1x B14

	B13	B14	B15	B16
C	20	20	20	20
H	16	16	16	16
L	13,8	13,8	13,8	19
D	6,5	6,5	6,5	6,5
ø	10	10	10	10
i	HV700	HV700	*	*
	x0,2mm	x0,2mm		
kg	~0,05	~0,05	~0,05	~0,06

* = weicher Stahl / soft steel

Separat bestellen / Separate order

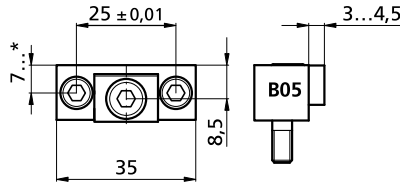
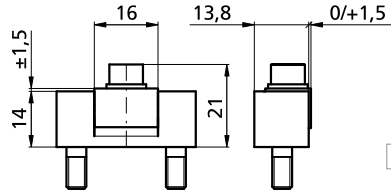

MS1F35N14-01

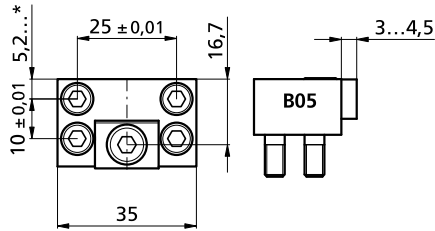
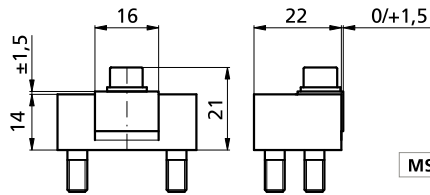
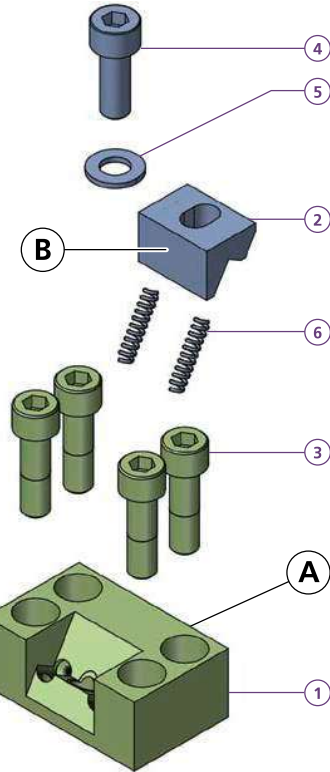
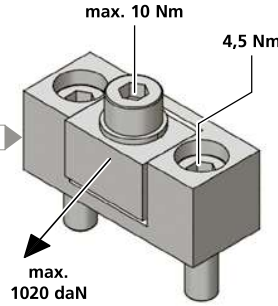

MS1F35N22-01

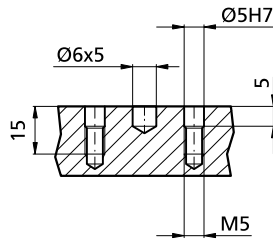
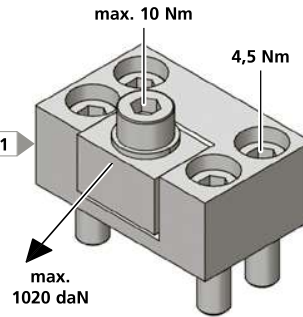

Beim Einsatz der Backe B05(R) Jaw B05(R) in use

Nachbearbeitung am Modul, falls If a stroke of 1,1mm to 1,5mm der gesamte Backenhub (1,1mm bis is required the module must be 1,5mm) benötigt wird. machined according to this sketch.

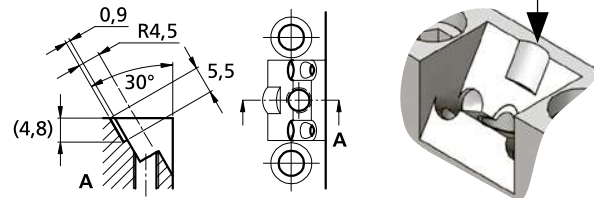

Achtung: Bei Spannkraften über 400 daN (0,4t) muss das Spannmodul in eine Nut eingelassen werden (Nuttiefe mindestens 1mm)

Remark: Using forces higher than 400 daN, clamps must be mounted into a slot (depth minimum 1mm)

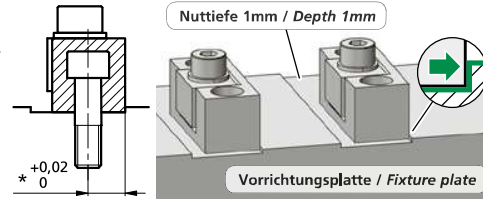

MS1F35N14-01	A
1x TF140718	1
MS1R35N14-01	B
1x TK190150	1
1x	2
2x MS50	3
1x M5X14ISO4762	4
1x 5x10x1DIN125A	5
2x FED02813	6
kg ~0,05	
MS1F35N22-01	A
1x TF140719	1
4x MS50	3
kg ~0,08	

Bestellbeispiel / Ordering example: 1x MS1F35N14-01 & 1x B02

	B01	B02	B03	B04	B05	B05R
C	16	16	16	16	16	16
H	10	10	10	10	10	10
L	8	8	11	8	10	10
D	5,5	5,5	5,5	5,5	5,2	5,2
e	4	4	4	4	4	4
i	HV700	HV700	*	Messing	HV700	HV700
	x0,2mm	x0,2mm		Laiton	x0,2mm	x0,2mm
kg	~0,01	~0,01	~0,014	~0,012	~0,014	~0,014

M5X10DIN6912

Separat bestellen / Separate order



MS2F60N14-01

microCLAMP

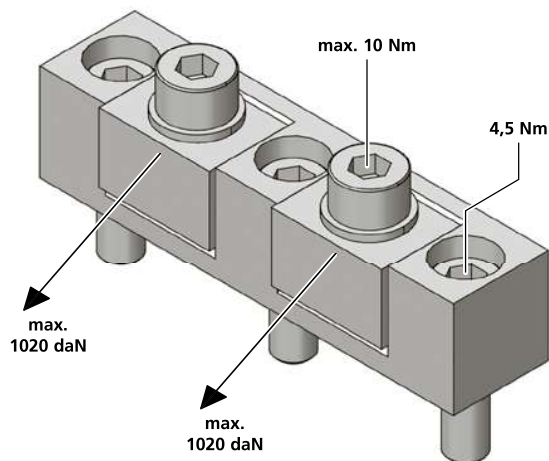
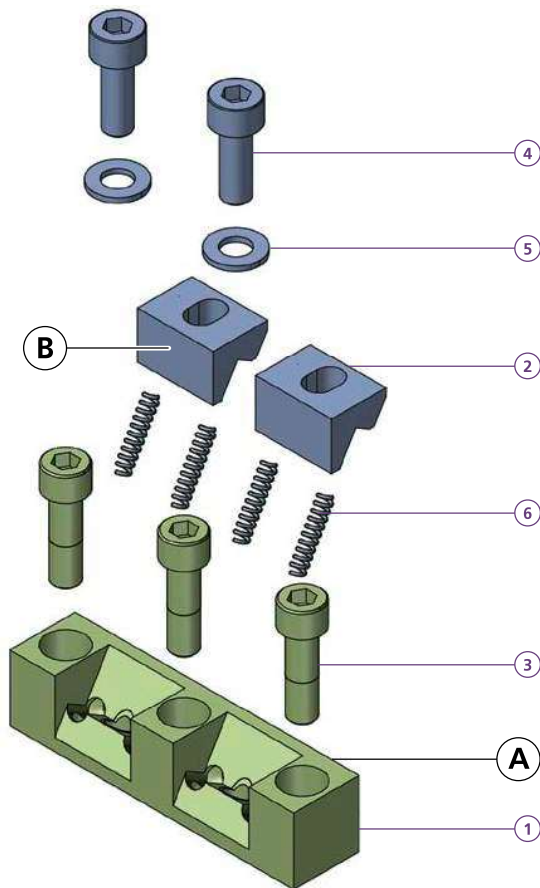
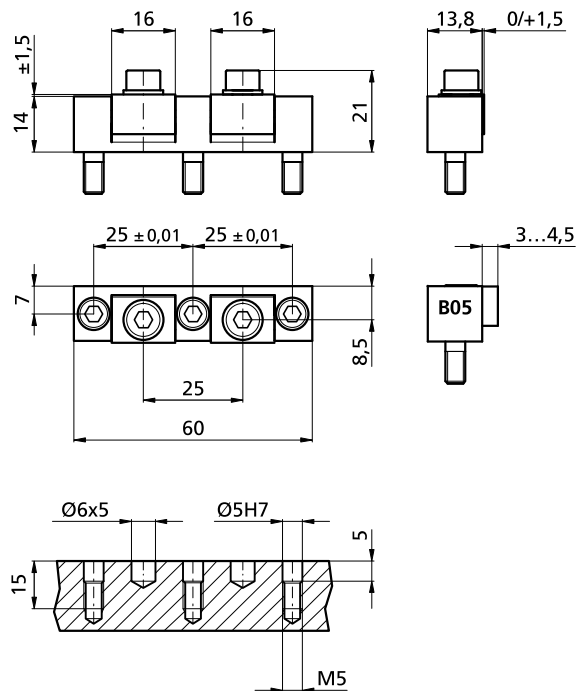

Beim Einsatz der Backe B05(R) Jaw B05(R) in use
 Nachbearbeitung am Modul, falls If a stroke of 1,1mm to 1,5mm
 der gesamte Backenhub (1,1mm bis is required the module must be
 1,5mm) benötigt wird. machined according to this sketch.

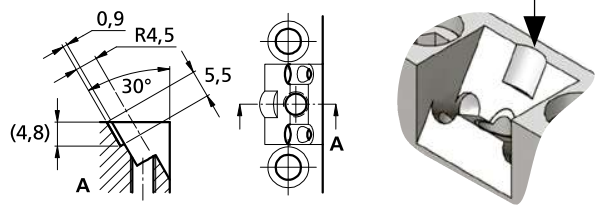

Achtung: Bei Spannkraften über 400 daN (0,4t) muss das Spannmodul in eine Nut eingelassen werden (Nuttiefe mindestens 1mm)

Remark: Using forces higher than 400 daN, clamps must be mounted into a slot (depth minimum 1mm)

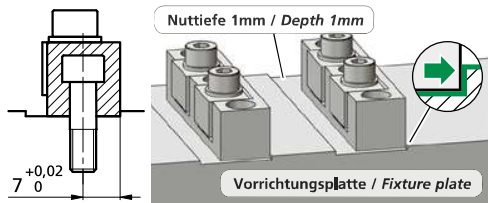

Bestellbeispiel / Ordering example: 1x MS2F60N14-01 & 2x B02

MS2F60N14-01	B01	B02	B03	B04	B05	B05R
1x TF140721						
2x						
3x MS50						
2x M5X14ISO4762						
2x 5x10x1DIN125A						
4x FED02813						
kg ~0,09	kg ~0,01	kg ~0,01	kg ~0,014	kg ~0,012	kg ~0,014	kg ~0,014

	C	H	L	D	i
B01, B02, B03, B04	16	10	8	5,5	HV700
B05	16	10	8	5,5	Messing
B05R	16	10	10	5,2	HV700

M5X10DIN6912



MS3F85N14-01

microCLAMP

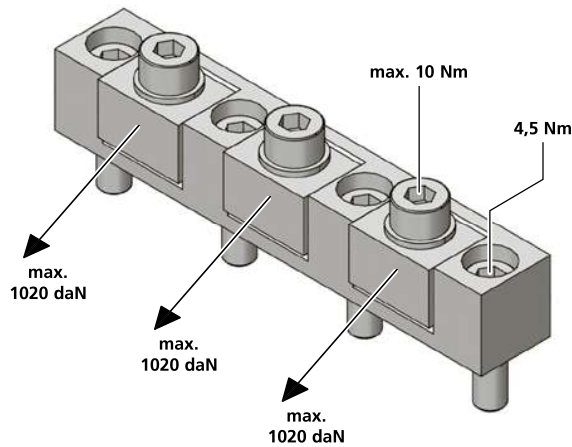
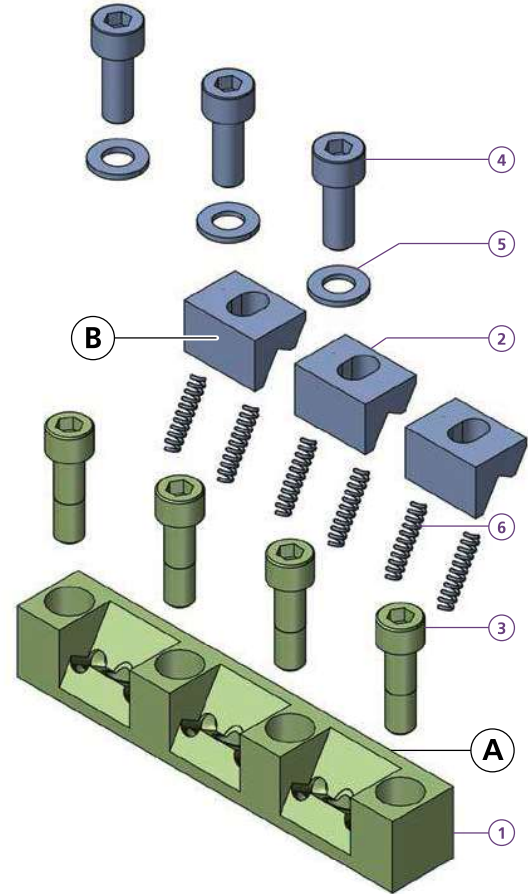
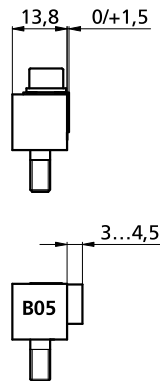
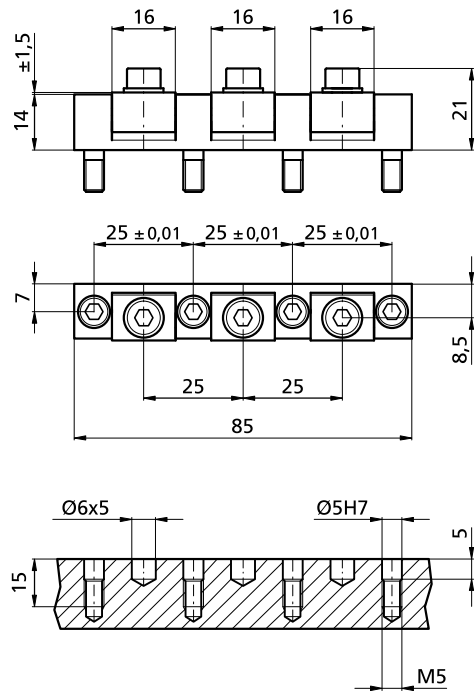

Beim Einsatz der Backe B05(R) Jaw B05(R) in use
 Nachbearbeitung am Modul, falls If a stroke of 1,1mm to 1,5mm
 der gesamte Backenhub (1,1mm bis is required the module must be
 1,5mm) benötigt wird. machined according to this sketch.

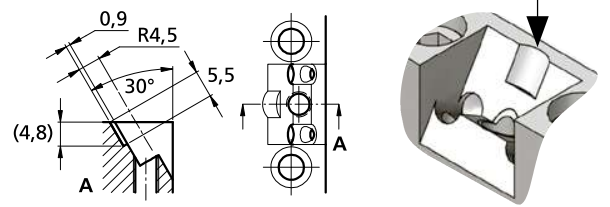

Achtung: Bei Spannkraften über 400 daN (0,4t) muss das Spannmodul in eine Nut eingelassen werden (Nuttiefe mindestens 1mm)

Remark: Using forces higher than 400 daN, clamps must be mounted into a slot (depth minimum 1mm)

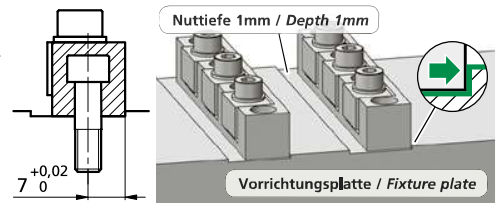

Bestellbeispiel / Ordering example: 1x MS3F85N14-01 & 3x B02

MS3F85N14-01	B01	B02	B03	B04	B05	B05R
1x TH160579						
3x						
4x MS50						
3x M5X14ISO4762						
3x 5x10x1DIN125A						
6x FED02813						
kg ~0,125	kg ~0,01	kg ~0,01	kg ~0,014	kg ~0,012	kg ~0,014	kg ~0,014

M5X10DIN6912

B01, B02, B03, B04

B05, B05R

* = weicher Stahl / soft steel

Separat bestellen / Separate order



VS1R/F19N35-20

microCLAMP

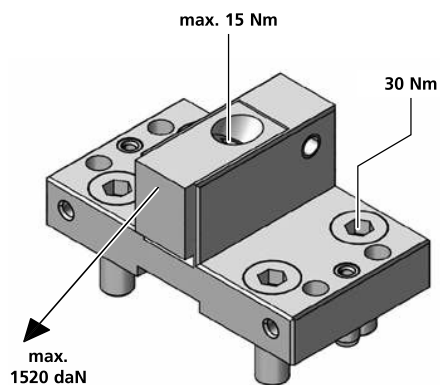
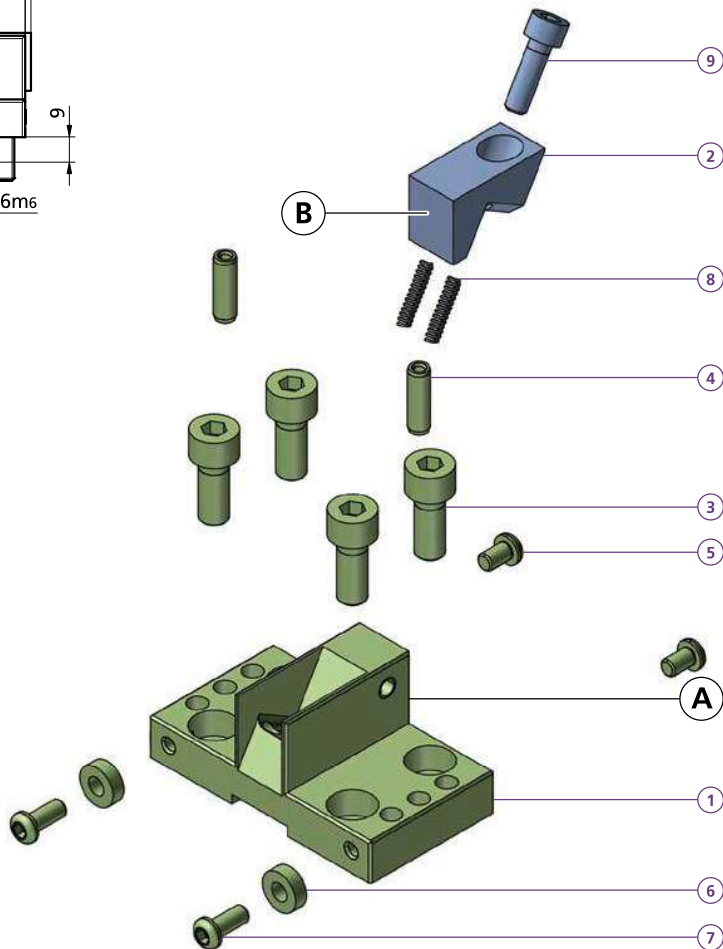
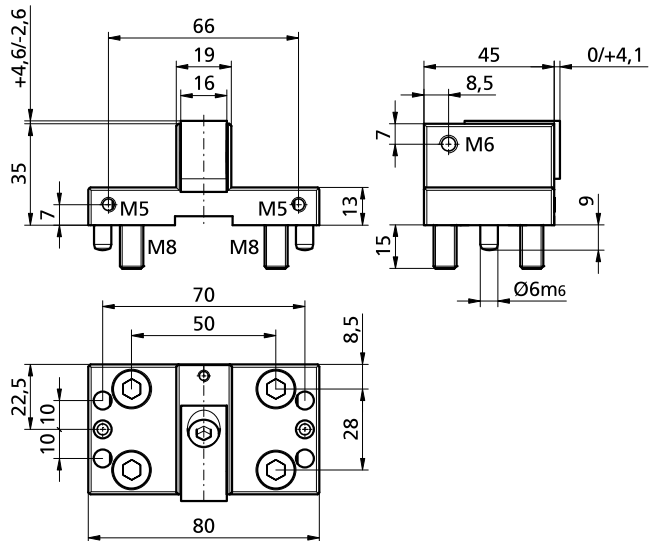

	VS1F19N35-20
1	1x TF150029
	VS1R19N35-20
1	1x TF140723
2	1x
3	4x M8X20ISO4762
4	2x CCBO0802
5	2x M5X8ISO7380
6	2x CCD004
7	2x M5X12ISO7380
8	2x FED0418
9	1x M6X20ISO4762
kg	~0,505

B Bestellbeispiel / Ordering example: 1x VS1R19N35-20 & 1x B21

	B20	B21	B22
C	16	16	16
H	20	20	20
L	19	19	19
D	6,5	6,5	6,5
e	12	12	12
i	HV700 x0,2mm	HV700 x0,2mm	*
kg	~0,011	~0,011	~0,011

B20, B21, B22

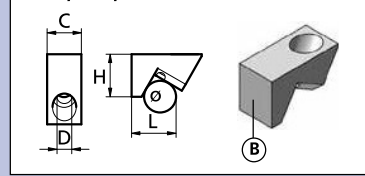

Separat bestellen / Separate order



VS1R26N35-26

microCLAMP

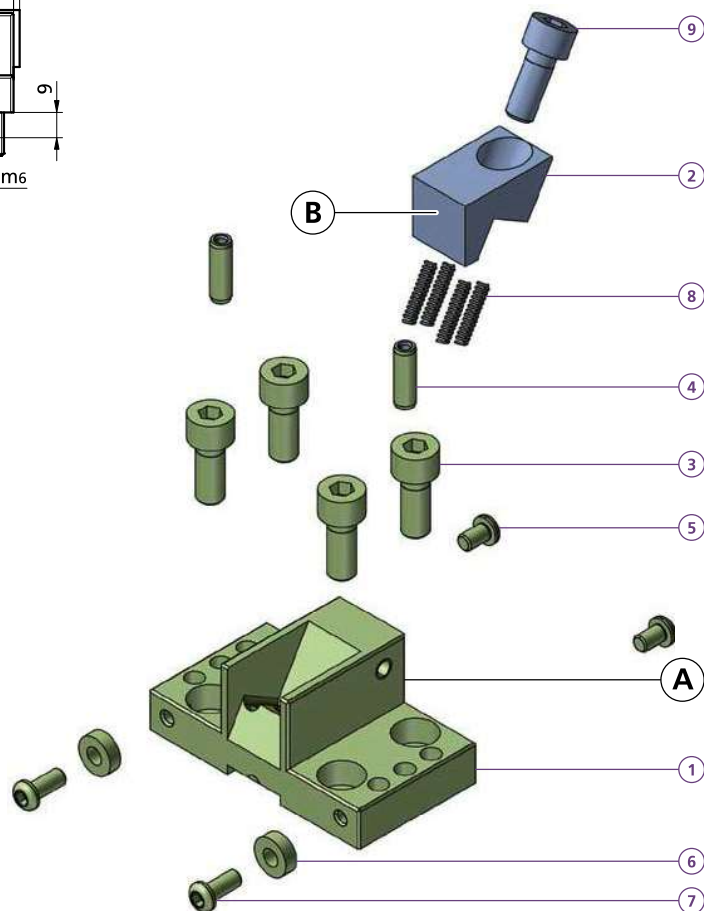
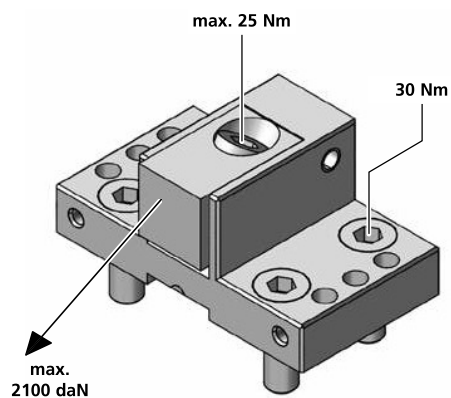
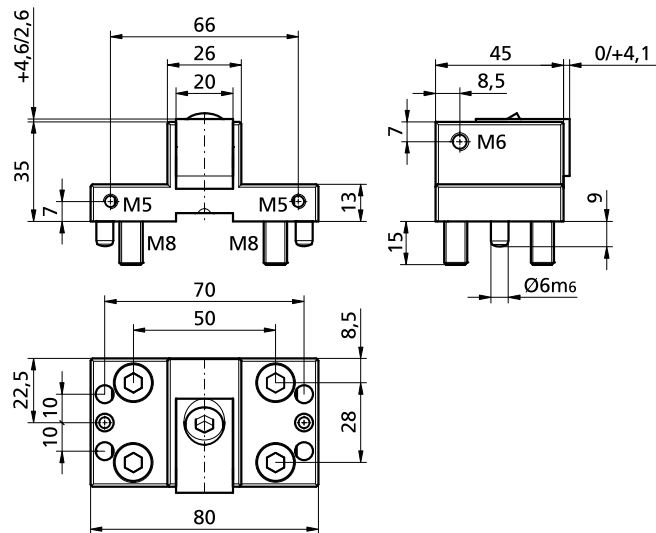

VS1R26N35-26	
1	1x TF140725
2	1x
3	4x M8X20ISO4762
4	2x CCBO0802
5	2x M5X8ISO7380
6	2x CCD004
7	2x M5X12ISO7380
8	4x FED0418
9	1x M8X20ISO4762
kg	~0,55

* = weicher Stahl / soft steel

B Bestellbeispiel / Ordering example: 1x VS1R26N35-26 & 1x B27

	B26	B27	B28
C	20	20	20
H	20	20	20
L	19	19	19
D	9	9	9
e	12	12	12
i	HV700 x0,2mm	HV700 x0,2mm	*
kg	~0,064	~0,064	~0,064

B26, B27, B28

Separat bestellen / Separate order



VS1R38N50-60

microCLAMP

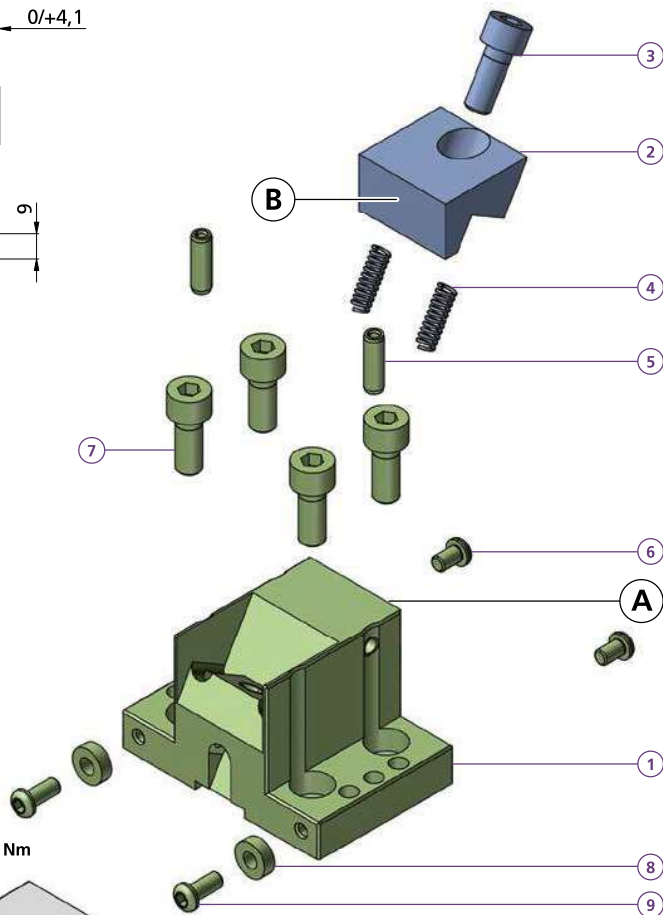
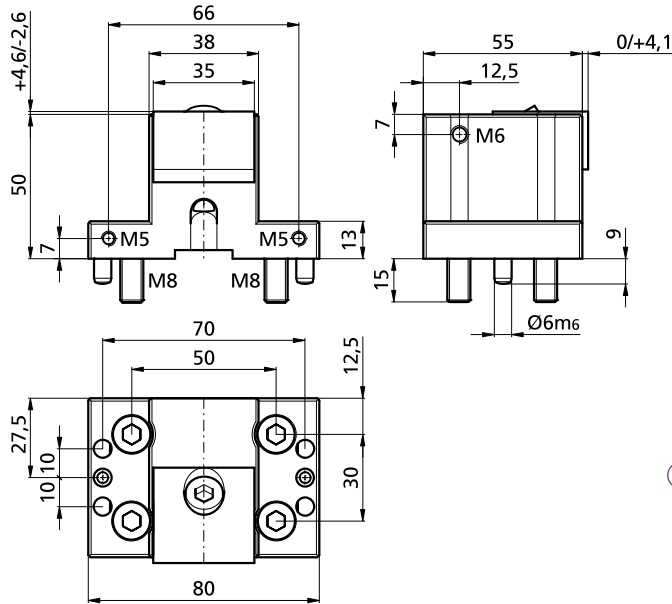

VS1R38N50-60

1	1x	TF140726
2	1x	
3	1x	M8X20ISO4762
4	2x	FED0618
5	2x	CCBO0802
6	2x	M5X8ISO7380
7	4x	M8X20ISO4762
8	2x	CCD004
9	2x	M5X12ISO7380
kg		~1,01

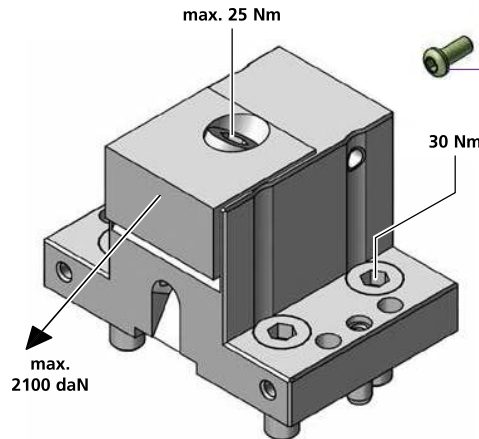

Bestellbeispiel / Ordering example: 1x VS1R38N50-60 & 1x B61

	B58	B60	B61	B62	B62HM	B65	B66	B67	B68	B69	B77	B79F	B79R
C	35	35	35	35	35	35	35	35	35	35	35	35	35
H	20	20	20	20	20	20	20	20	20	25	20	20	20
L	26	19	19	19	19	19	19	24	26	22	22	25	25
D	9	9	9	9	9	9	9	9	9	9	9	9	9
ø	12	12	12	12	12	12	12	12	12	12	12	12	12
i	ALU	56HRC	56HRC	*	HM	HV700	HV700	HV700	*	*	56HRC	HV700	HV700
		x0,2mm	x0,2mm	x0,2mm		x0,2mm	x0,2mm	x0,2mm				x0,2mm	x0,2mm
kg	~0,07	~0,12	~0,12	~0,12	~0,12	~0,12	~0,12	~0,14	~0,15	~0,15	~0,12	~0,18	~0,18

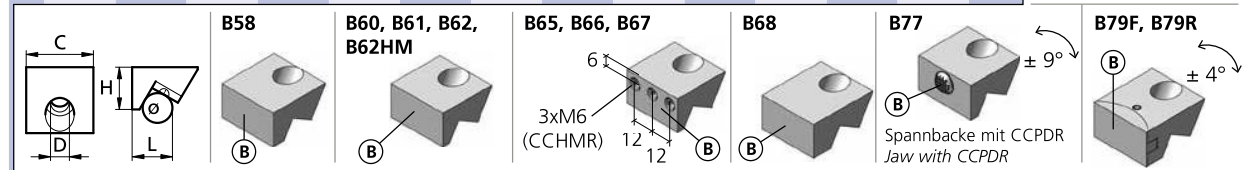
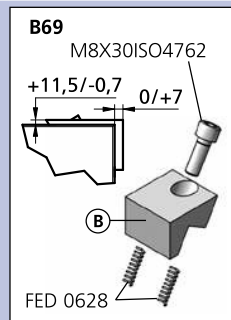



VS1R/F41N30-60

microCLAMP

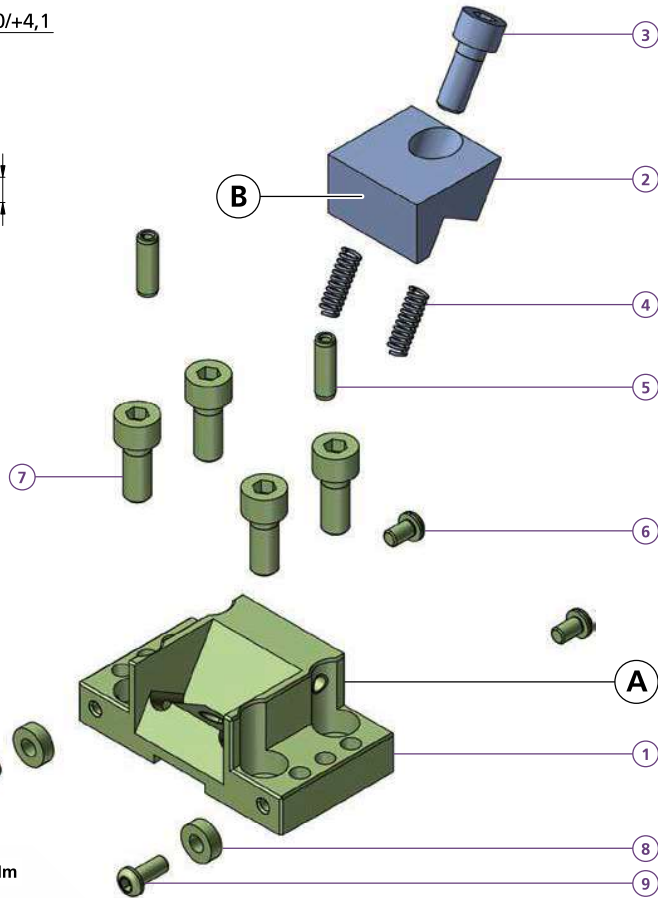
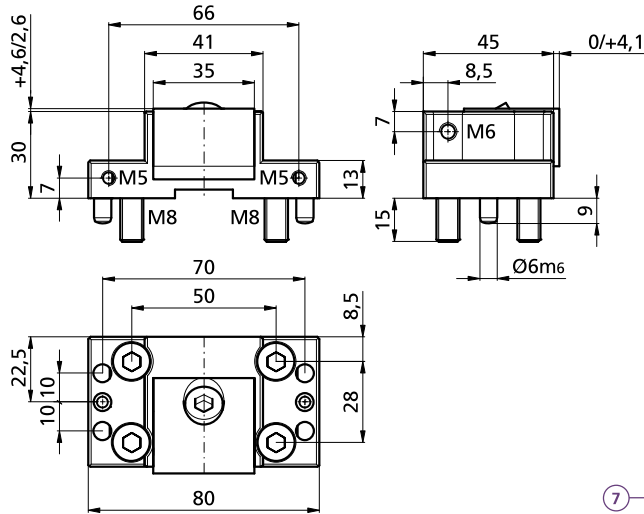

- VS1F41N30-60**
- 1x TF140729
- VS1R41N30-60**
- 1x TF140730
- 1x
- 1x M8X20ISO4762
- 2x FED0618
- 2x CCBO0802
- 2x M5X8ISO7380
- 4x M8X20ISO4762
- 2x CCD004
- 2x M5X12ISO7380
- kg ~0,58

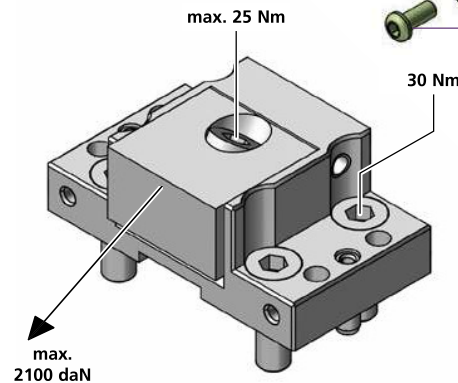

Bestellbeispiel / Ordering example: 1x VS1R41N30-60 & 1x B61

	B58	B60	B61	B62	B62HM	B65	B66	B67	B68	B77	B79F	B79R
C	35	35	35	35	35	35	35	35	35	35	35	35
H	20	20	20	20	20	20	20	20	20	20	20	20
L	26	19	19	19	19	19	19	24	26	22	25	25
D	9	9	9	9	9	9	9	9	9	9	9	9
ø	12	12	12	12	12	12	12	12	12	12	12	12
i	ALU	56HRC	56HRC	*	HM	HV700	HV700	HV700	*	56HRC	HV700	HV700
		x0,2mm	x0,2mm			x0,2mm	x0,2mm	x0,2mm			x0,2mm	x0,2mm
kg	~0,07	~0,12	~0,12	~0,12	~0,12	~0,12	~0,12	~0,14	~0,15	~0,12	~0,18	~0,18

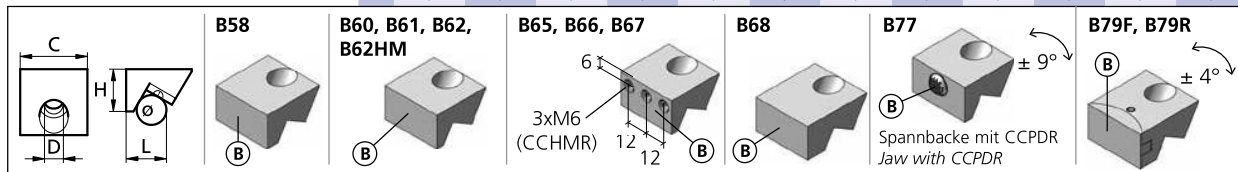

* = weicher Stahl / soft steel

HM = Hartmetallbeschichtet / Carbide coated

ALU = ENAW-7022

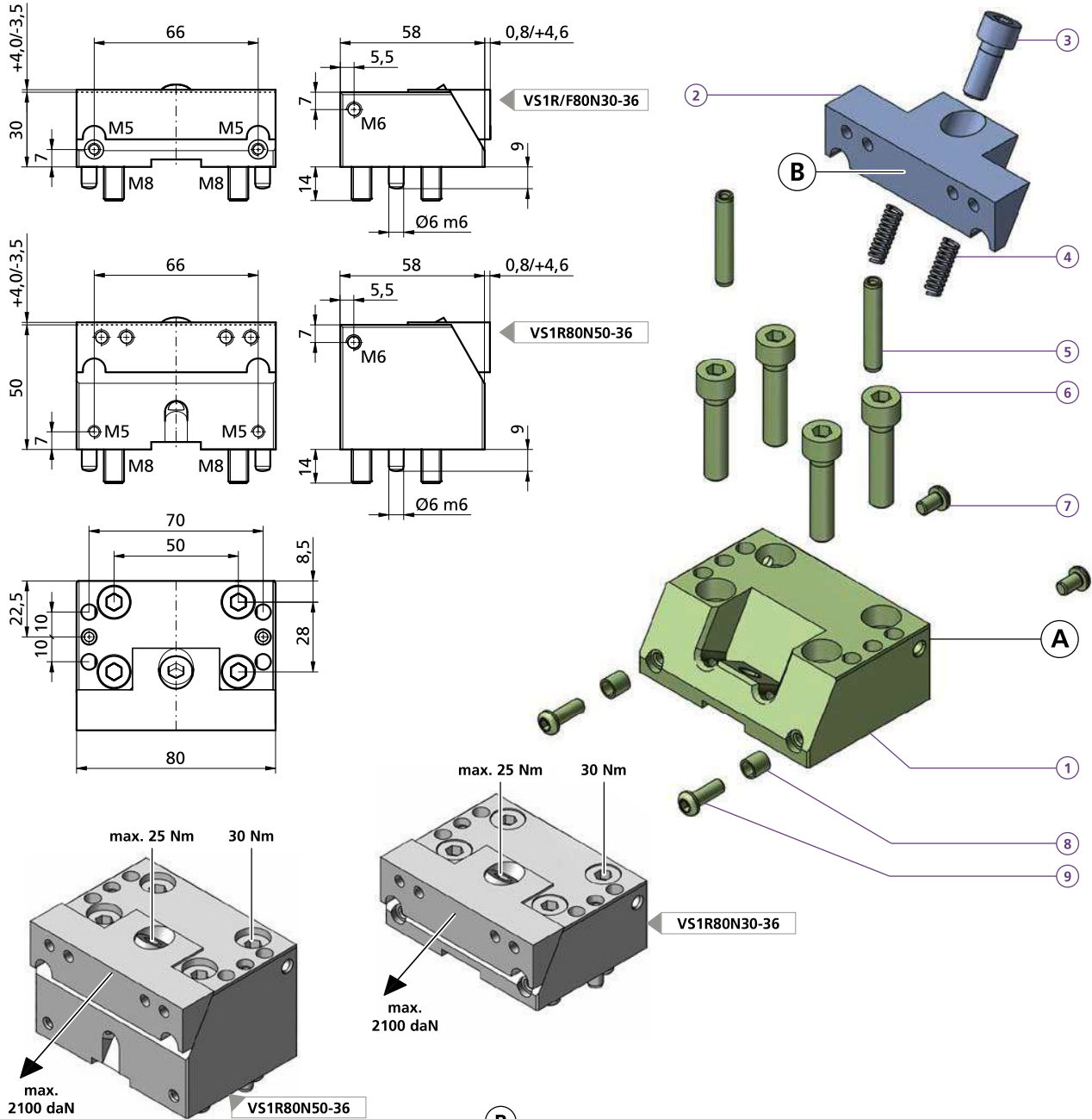

VS1F80N30-36	
1	1x TF140733
VS1R80N30-36	
1	1x TF140734
2	1x
3	1x M8X20ISO4762
4	4x FED0618
5	2x CCBO0801
6	4x M8X35ISO4762
7	2x M5X8ISO4762
8	2x CCD007
9	2x M5X16ISO7380
kg	~1,2

VS1R80N50-36	
1	1x TF140742
2	1x
5	2x CCBO0803
6	4x M8X55ISO4762
8	2x CCD005
9	2x M5X12ISO7380
kg	~1,9

Bestellbeispiel / Ordering example: 1x VS1R80N30-36 & 1x B37

	B36	B37	B38
C	80	80	80
H	20	20	20
L	19	19	19
D	9	9	9
ø	12	12	12
i	HV700	HV700	*
	x0,2mm	x0,2mm	
kg	~0,18	~0,18	~0,18

B36, B37, B38

Separat bestellen / Separate order



VS1R/F80N30-60

microCLAMP

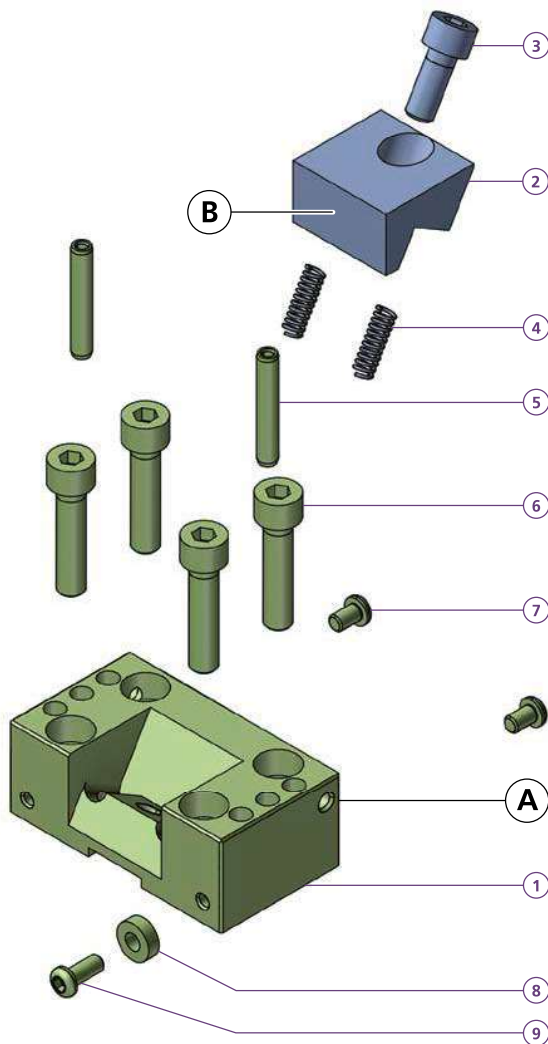
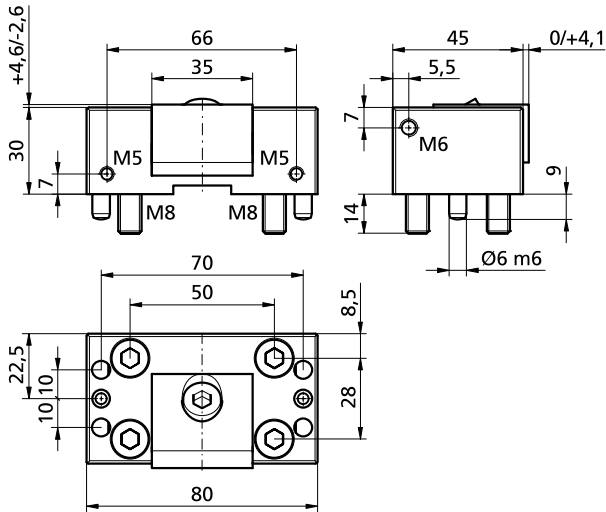

- VS1F80N30-60**
- 1x TF140735
- VS1R80N30-60**
- 1x TF140736
- 1x
- 1x M8X20ISO4762
- 2x FED0618
- 2x CCBO0801
- 4x M8X35ISO4762
- 2x M5X8ISO7380
- 2x CCD004
- 2x M5X12ISO7380
- kg ~0,74

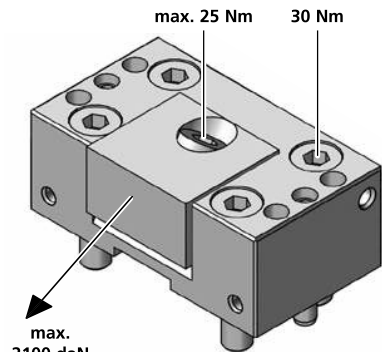

Bestellbeispiel / Ordering example: 1x VS1F80N30-60 & 1x B61

	B58	B60	B61	B62	B62HM	B65	B66	B67	B68	B77	B79F	B79R
C	35	35	35	35	35	35	35	35	35	35	35	35
H	20	20	20	20	20	20	20	20	20	20	20	20
L	26	19	19	19	19	19	19	24	26	22	25	25
D	9	9	9	9	9	9	9	9	9	9	9	9
ø	12	12	12	12	12	12	12	12	12	12	12	12
i	ALU	56HRC	56HRC	*	HM	HV700	HV700	HV700	*	56HRC	HV700	HV700
		x0,2mm	x0,2mm			x0,2mm	x0,2mm	x0,2mm			x0,2mm	x0,2mm
kg	~0,07	~0,12	~0,12	~0,12	~0,12	~0,12	~0,12	~0,14	~0,15	~0,12	~0,18	~0,18

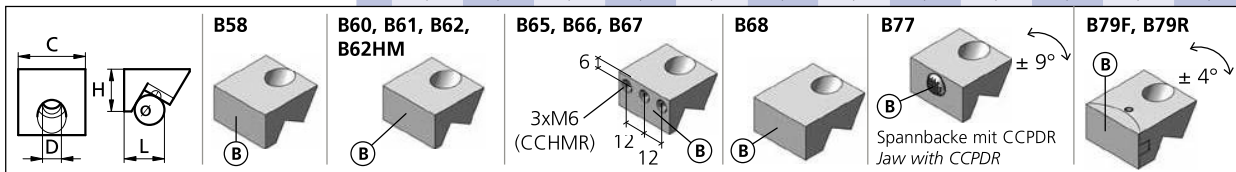

* = weicher Stahl / soft steel

HM = Hartmetallbeschichtet / Carbide coated

ALU = ENAW-7022



VS1R80N50-60

microCLAMP

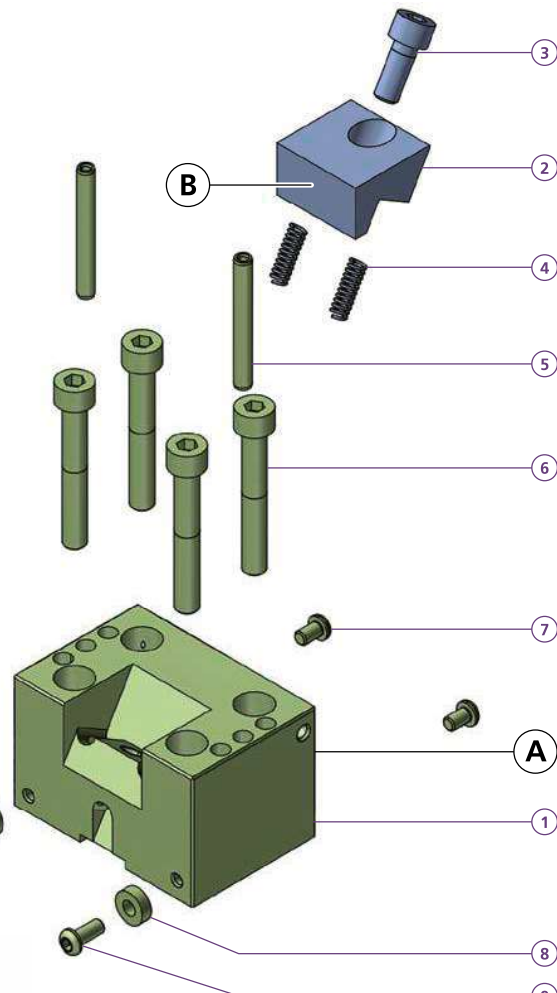
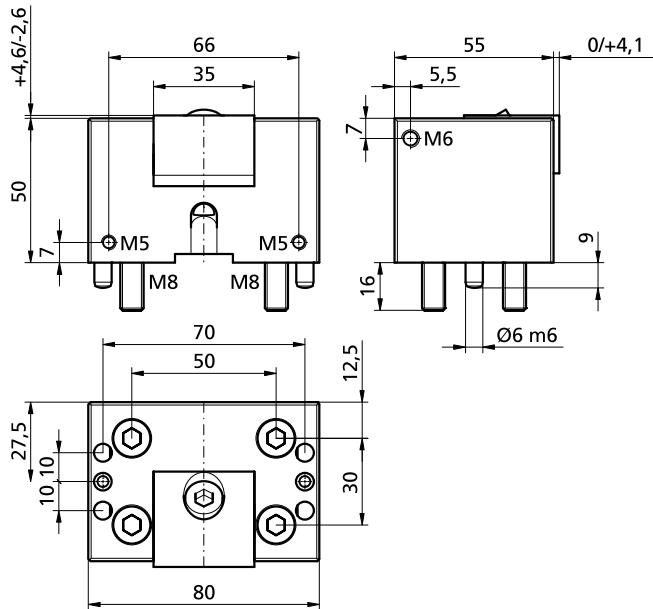

- VS1R80N50-60**
- 1x TF140737
 - 1x
 - 1x M8X20ISO4762
 - 2x FED0618
 - 2x CCBO0803
 - 4x M8X55ISO4762
 - 2x M5X8ISO7380
 - 2x CCD004
 - 2x M5X12ISO7380
- kg ~1,6

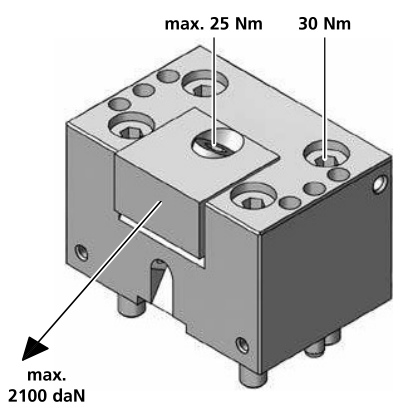

Bestellbeispiel / Ordering example: 1xVS1R80N50-60 & 1x B61

	B58	B60	B61	B62	B62HM	B65	B66	B67	B68	B69	B77	B79F	B79R
C	35	35	35	35	35	35	35	35	35	35	35	35	35
H	20	20	20	20	20	20	20	20	20	25	20	20	20
L	26	19	19	19	19	19	19	24	26	22	22	25	25
D	9	9	9	9	9	9	9	9	9	9	9	9	9
ø	12	12	12	12	12	12	12	12	12	12	12	12	12
i	ALU	56HRC	56HRC	*	HM	HV700	HV700	HV700	*	*	56HRC	HV700	HV700
		x0,2mm	x0,2mm	x0,2mm		x0,2mm	x0,2mm	x0,2mm			x0,2mm	x0,2mm	x0,2mm
kg	~0,07	~0,12	~0,12	~0,12	~0,12	~0,12	~0,12	~0,14	~0,15	~0,15	~0,12	~0,18	~0,18

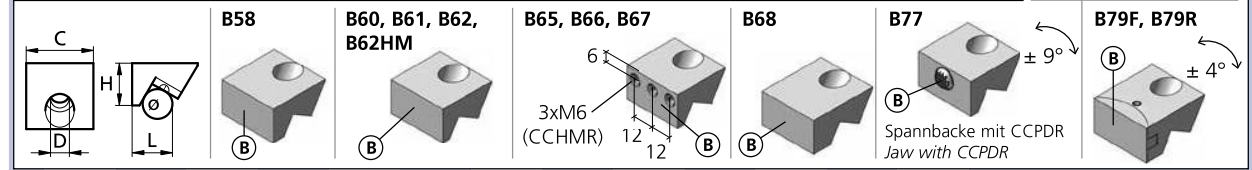
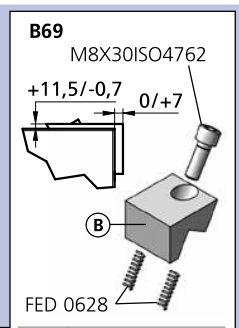

Separat bestellen / Separate order

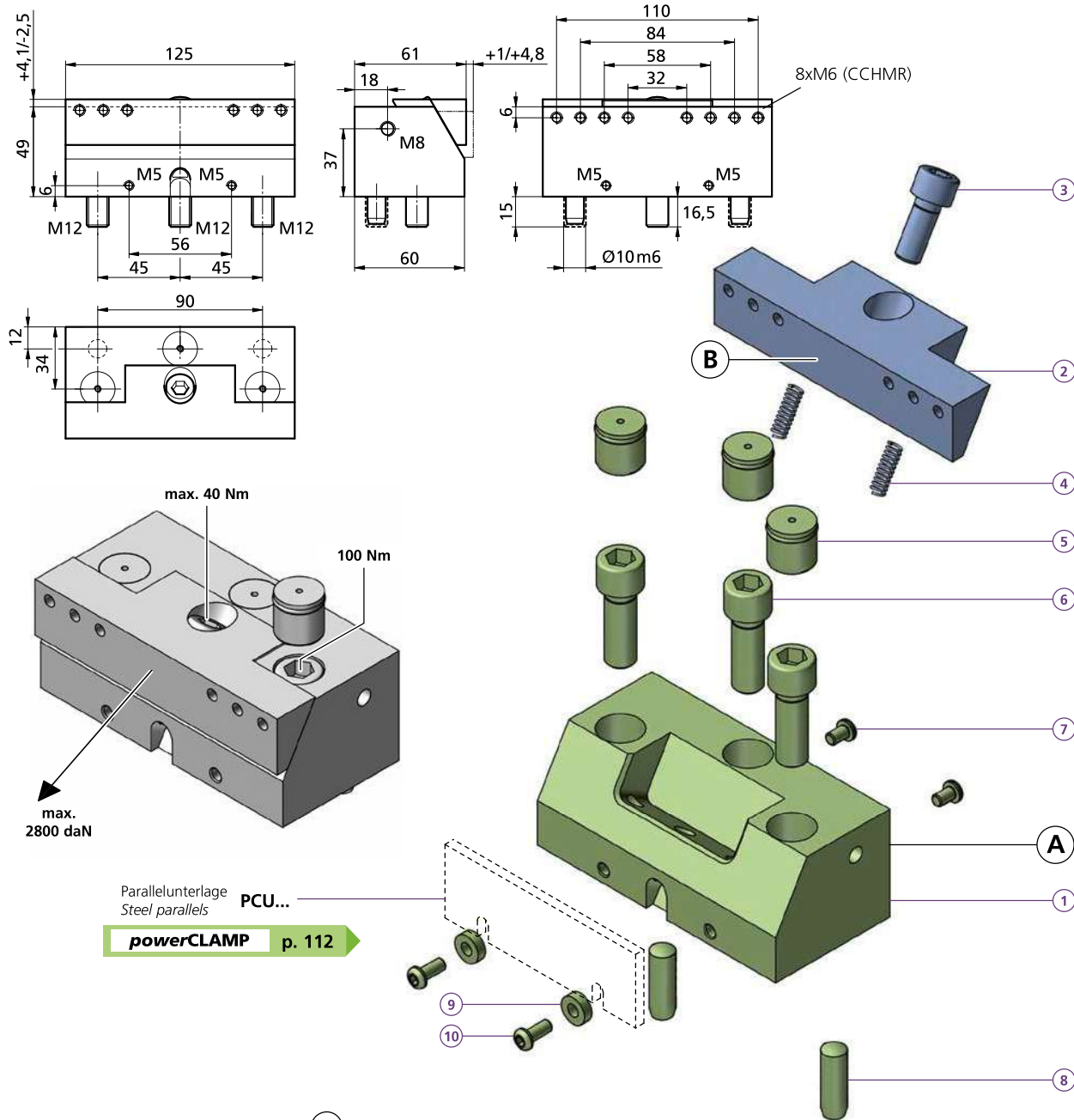

Bestellbeispiel / Ordering example: 1x VS1R125N49-95 & 1x B96

	B95	B96	B97	B98	B99
VS1F125N49-95					
1x TF140738					
VS1R125N49-95					
1x TF140739					
1x					
1x M10X25ISO4762					
2x FED0618					
3x PCPF16L18Alu					
3x M12X35ISO4762					
3x M5X8ISO7380					
2x 10m6x30 DIN6325					
2x CCD004					
2x M5X12ISO7380					
kg	~2,6				

	B95	B96	B97	B98	B99
C	125	125	125	125	125
H	25	25	25	25	25
L	23	23	23	30	23
D	11	11	11	11	11
e	15	15	15	15	15
i	HV700 x0,2mm	HV700 x0,2mm	*	*	HV700 x0,2mm
kg	~0,45	~0,45	~0,45	~0,63	~0,45

B95, B96, B97, B99

B98

Separat bestellen / Separate order

* = weicher Stahl / soft steel



VS2R80N30-60

microCLAMP

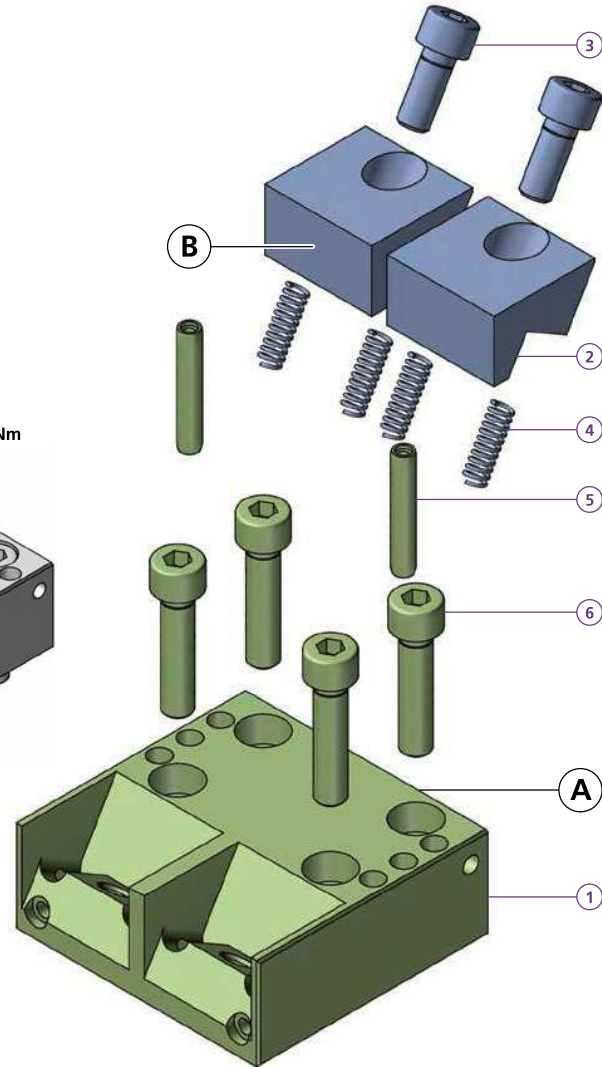
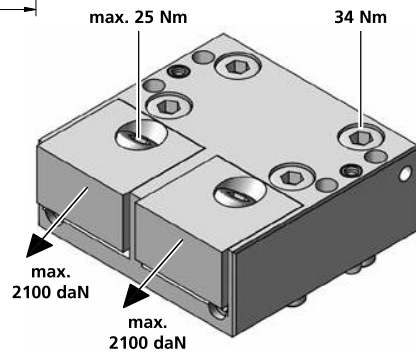
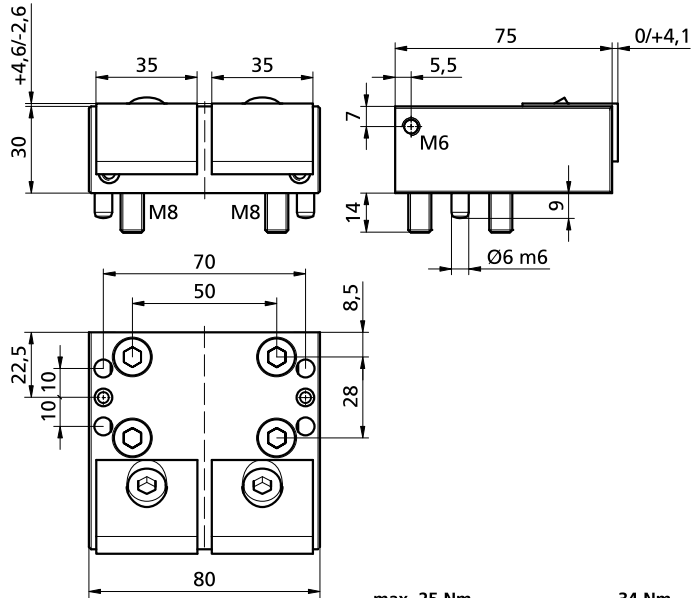

- VS2R80N30-60**
- 1 1x TF140740
 - 2 2x
 - 3 2x M8X20ISO4762
 - 4 4x FED0618
 - 5 2x CCBO0801
 - 6 4x M8X35ISO4762
- kg ~1,3

Bestellbeispiel / Ordering example: 1x VS2R80N30-60 & 2x B61

	B58	B60	B61	B62	B62HM	B65	B66	B67	B68	B77	B79F	B79R
C	35	35	35	35	35	35	35	35	35	35	35	35
H	20	20	20	20	20	20	20	20	20	20	20	20
L	26	19	19	19	19	19	19	24	26	22	25	25
D	9	9	9	9	9	9	9	9	9	9	9	9
ø	12	12	12	12	12	12	12	12	12	12	12	12
i	ALU	56HRC	56HRC	*	HM	HV700	HV700	HV700	*	56HRC	HV700	HV700
		x0,2mm	x0,2mm			x0,2mm	x0,2mm	x0,2mm			x0,2mm	x0,2mm
kg	~0,07	~0,12	~0,12	~0,12	~0,12	~0,12	~0,12	~0,14	~0,15	~0,12	~0,18	~0,18

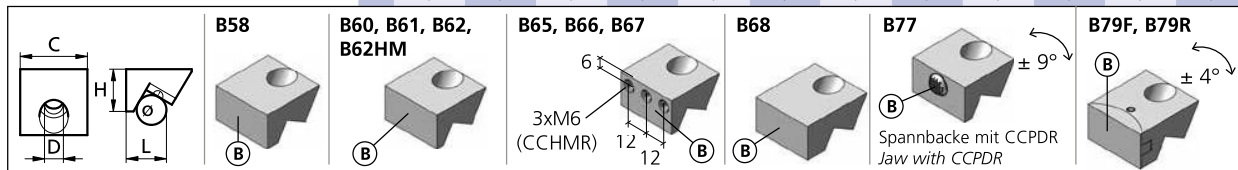



VS2F90N30-60

microCLAMP

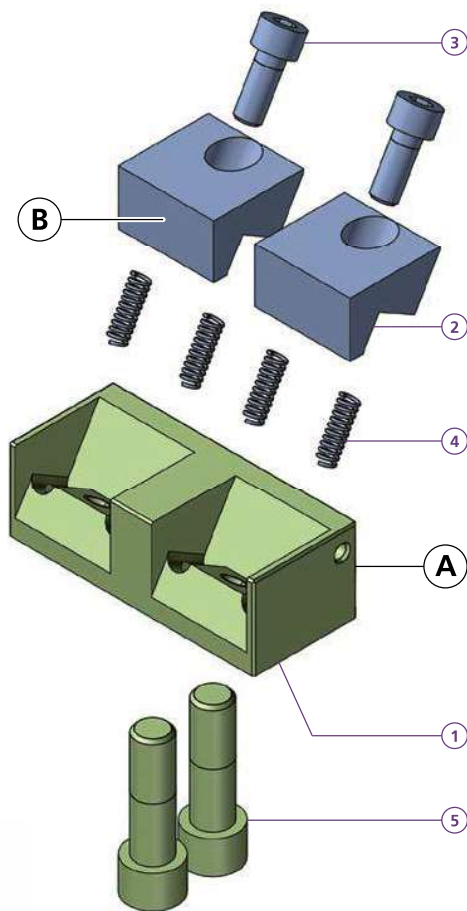
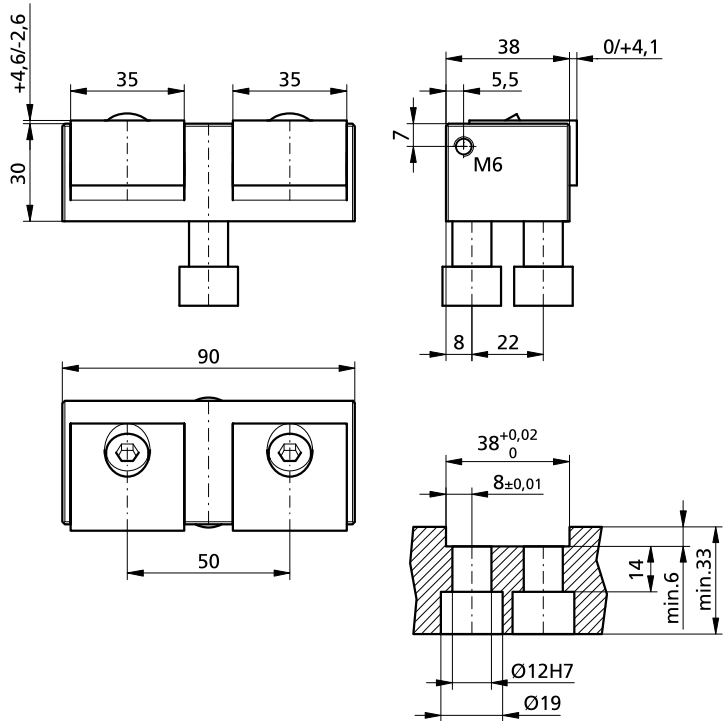

VS2F90N30-60	
1	1x TF140741
2	2x
3	2x M8X20ISO4762
4	4x FED0618
5	2x TWPAS1232
kg	~0,85

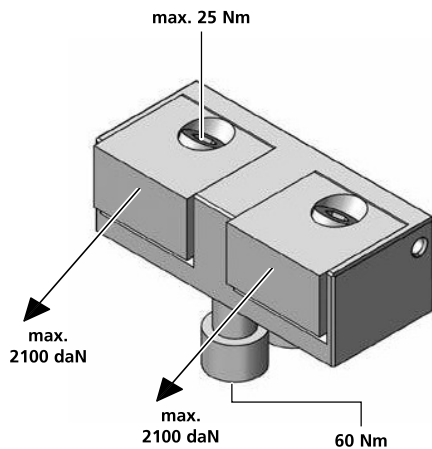

Bestellbeispiel / Ordering example: 1x VS2F90N30-60 & 2x B61

	B58	B60	B61	B62	B62HM	B65	B66	B67	B68	B77	B79F	B79R
C	35	35	35	35	35	35	35	35	35	35	35	35
H	20	20	20	20	20	20	20	20	20	20	20	20
L	26	19	19	19	19	19	19	24	26	22	25	25
D	9	9	9	9	9	9	9	9	9	9	9	9
ø	12	12	12	12	12	12	12	12	12	12	12	12
i	ALU	56HRC	56HRC	*	HM	HV700	HV700	HV700	*	56HRC	HV700	HV700
kg	~0,07	~0,12	~0,12	~0,12	~0,12	x0,2mm	x0,2mm	x0,2mm	~0,15	~0,12	~0,18	~0,18

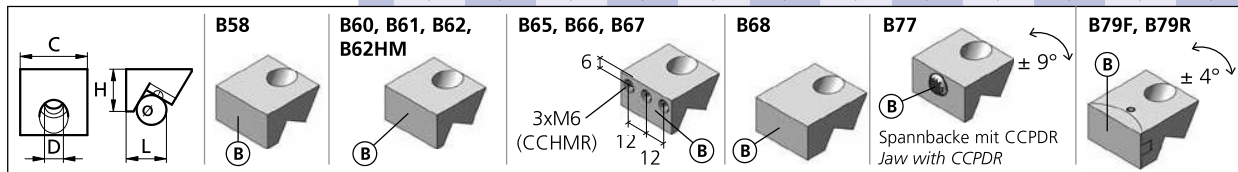

* = weicher Stahl / soft steel

HM = Hartmetallbeschichtet / Carbide coated

ALU = ENAW-7022

MS1R/F35L14-152

***MS1R/F35L14-150* (Alte Version / Old Version)**

microCLAMP

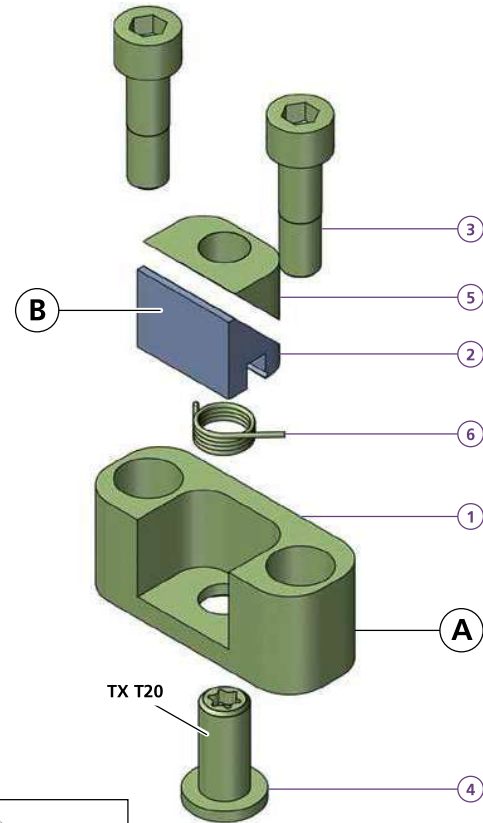
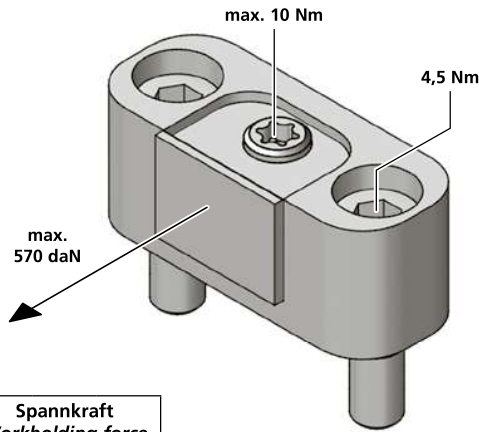
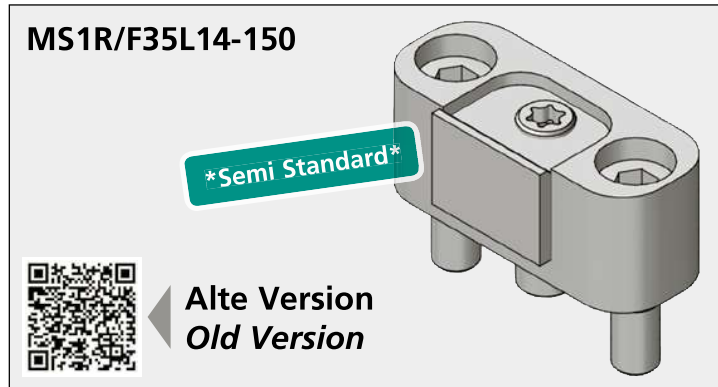
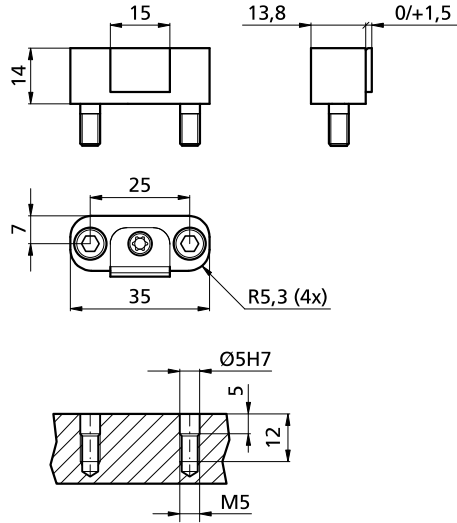





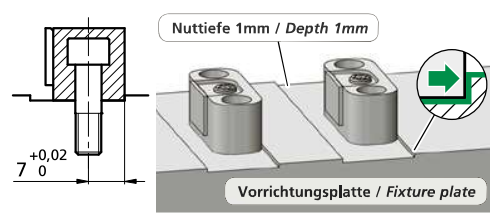

Drehmoment Torque		Spannkraft Workholding force		
Nm	(lb-ft)	~daN	~(lb)	~t
7	5,18	= 390	860	0,39
8	5,92	= 450	990	0,45
9	6,66	= 510	1120	0,51
10	7,4	= 570	1250	0,57

Achtung: Bei Spannkraften über 400 daN (0,4t) muss das Spannmodul in eine Nut eingelassen werden (Nuttiefe mindestens 1mm)

Remark: Using forces higher than 400 daN, clamps must be mounted into a slot (depth minimum 1mm)



MS1F35L14-152	
1x TK181266	
MS1R35L14-152	
1x TF190596	
1x	
2x MS50	
1x GEWST6L14	
1x MSK15W45	
1x SFED6W90	
kg ~0,03	

Bestellbeispiel / Ordering example: 1x MS1F35L14-152 & 1x B151

B150	B151
C 15	15
H 11	11
L 40,3	40,3
ø 40	40
i HV700	HV700
x0,2mm	x0,2mm
kg ~0,004	~0,004



B150, B151

Separat bestellen / Separate order

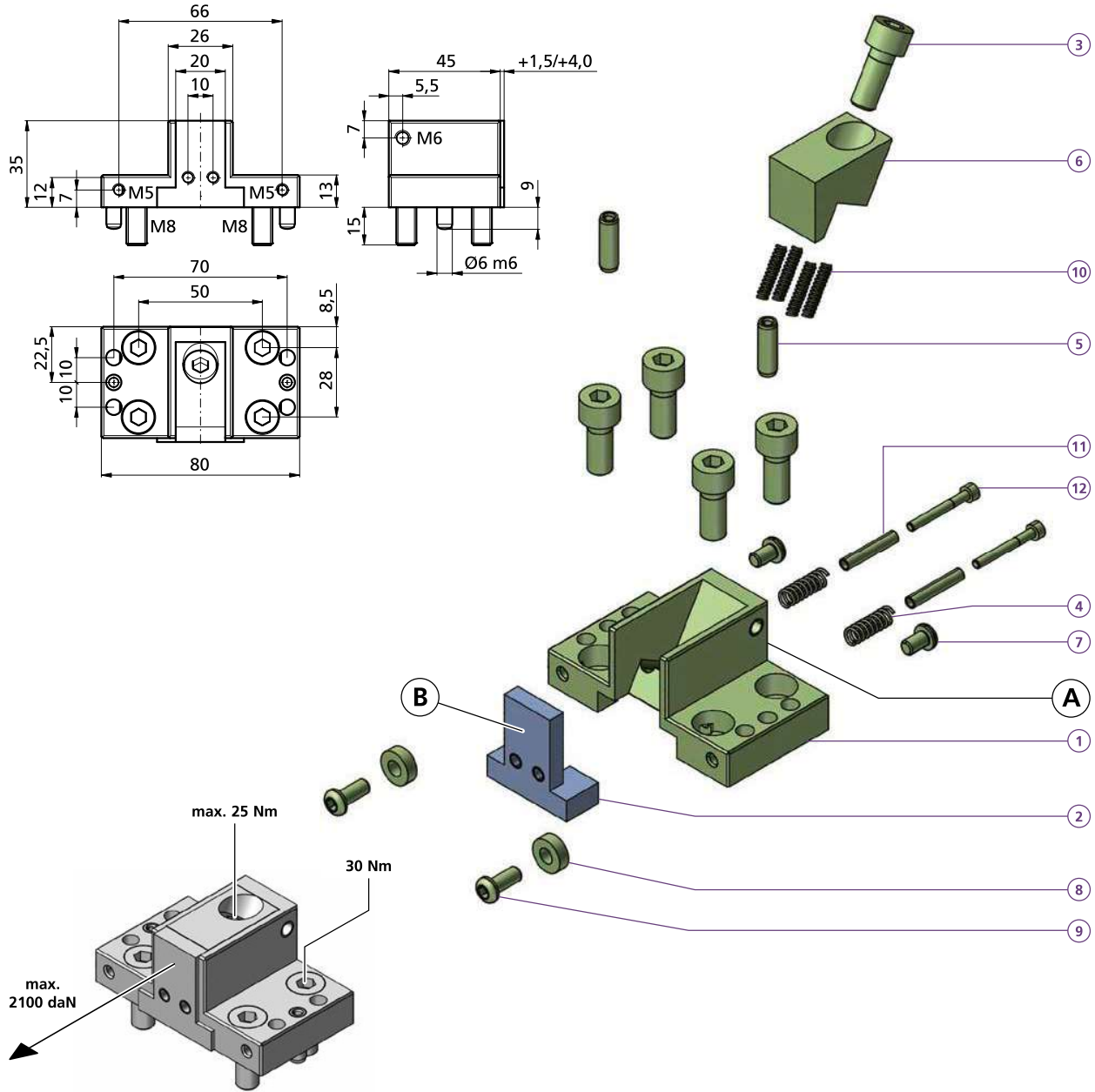

VS1R26L35-31

microCLAMP



VS1R26L35-31 	
1	1x TF140724
2	1x 
3	5x M8X20ISO4762
4	2x FED0618
5	2x CCBO0802
6	1x B30
7	2x M5X8ISO7380
8	2x CCD004
9	2x M5X12ISO7380
10	4x FED0418
11	2x CCD422
12	2x M3X25ISO4762
kg	~0,55

Bestellbeispiel / Ordering example: 1x VS1R26L35-31 & 1x B32

	 B31	 B32	 B33
C	20	20	20
H	35	35	35
L	6	6	6
D	-	-	-
e	-	-	-
i	HV700	HV700	*
	x0,2mm	x0,2mm	
kg	~0,046	~0,046	~0,046

B31, B32, B33

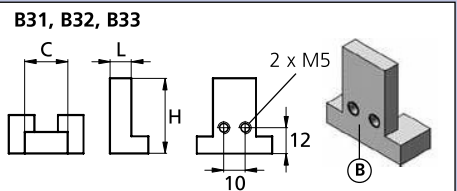

* = weicher Stahl / soft steel

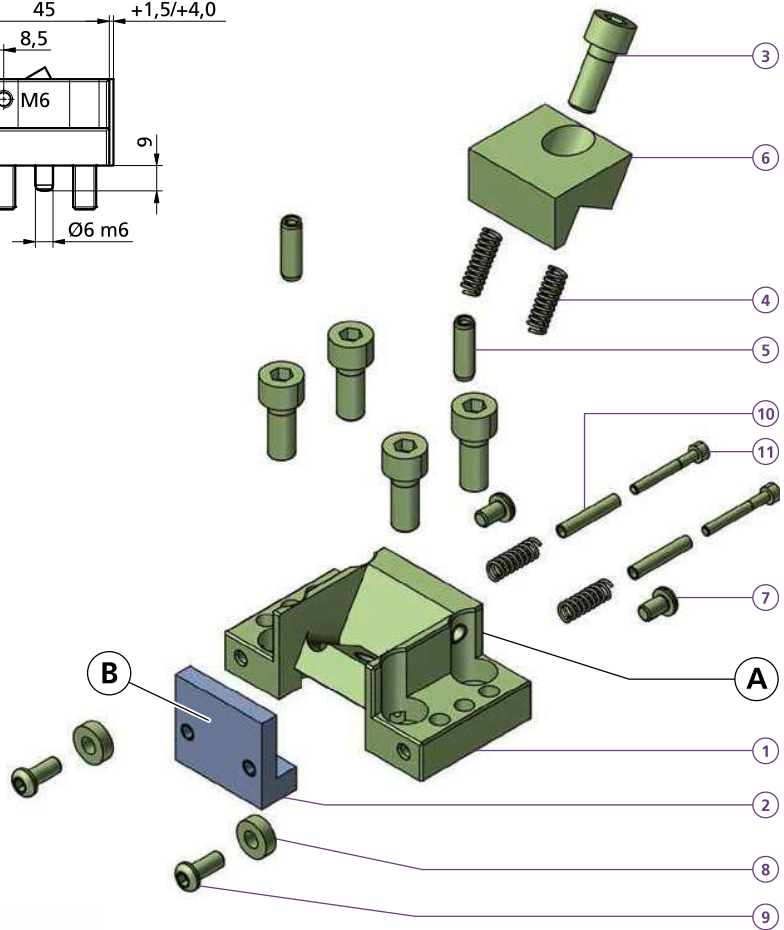
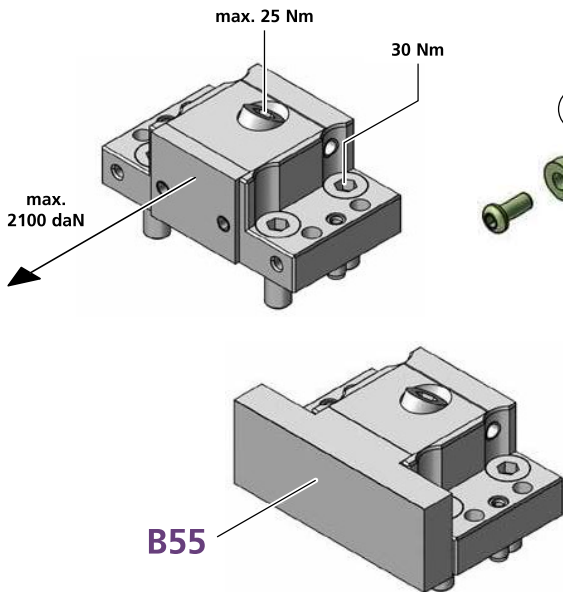
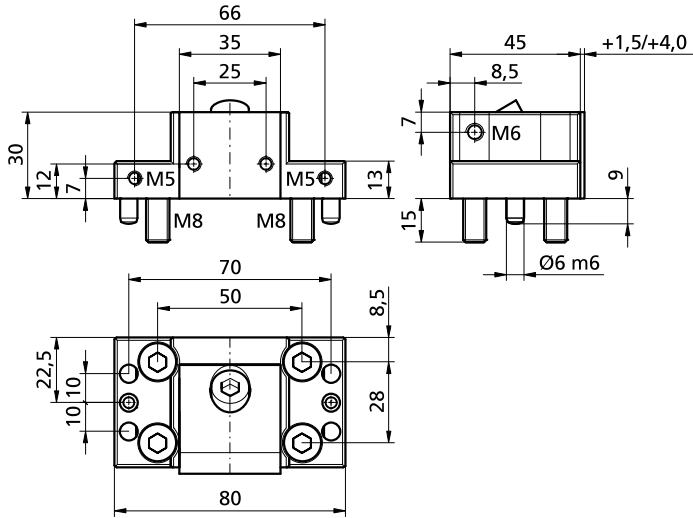

VS1F41L30-51	
1	1x TF140727
VS1R41L30-51	
1	1x TF140728
2	1x
3	5x M8X20ISO4762
4	4x FED0618
5	2x CCBO0802
6	1x B78
7	2x M5X8ISO7380
8	2x CCD004
9	2x M5X12ISO7380
10	2x CCD422
11	2x M3X25ISO4762
kg	~0,545

Bestellbeispiel / Ordering example: 1x VS1R41L30-51 & 1x B52

	B51	B52	B53	B54	B55
C	35	35	35	35	80
H	30	30	30	35	30
L	6	6	10	10	11,5
D	-	-	-	-	-
e	-	-	-	-	-
i	HV700	HV700	*	*	*
	x0,2mm	x0,2mm			
kg	~0,06	~0,06	~0,06	~0,12	~0,27

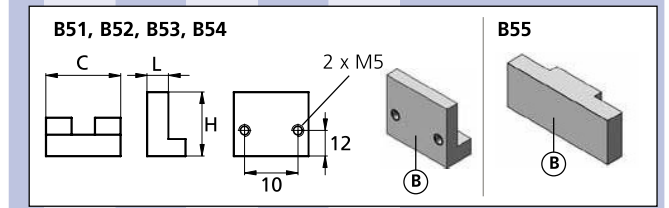

Separat bestellen / Separate order

Vorrichtungsbau-Modul für Linearbacken

Alle bestehenden Linearbacken passen auf dieses Modul (**powerCLAMP** Seite 82 - 85). In die Vorrichtungsplatte wird eine Tasche gefräst um das Modul zu positionieren. Gut geeignet sind die Anschlagbacken **MAND** und **MANF** um als Gegenbacke zu dienen.

Fixture clamp module for linear jaws

All of our standard linear jaws fit to this clamp module (**powerCLAMP** Page 82 - 85). All to do is milling a pocket to fit and positioning the clamp modules. To use the **MAND** and **MANF** as datum stop will make a perfect match. (Seite / Page 175 - 176)

Fertigungsmasse für die Vorrichtungsplatte
Machining data for the fixture plate

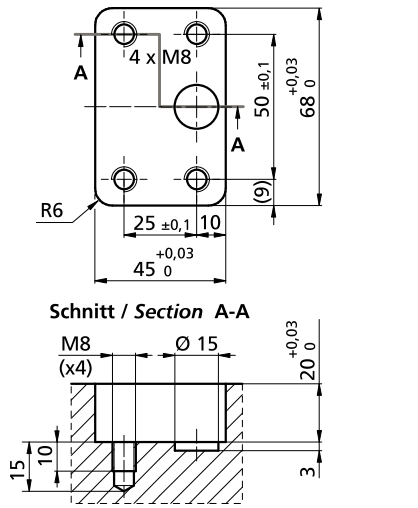

Das Fertigungsmass gilt auch für das Anschlagmodul.
 The production dimension is also valid for the end module. (VA168-20PRG)

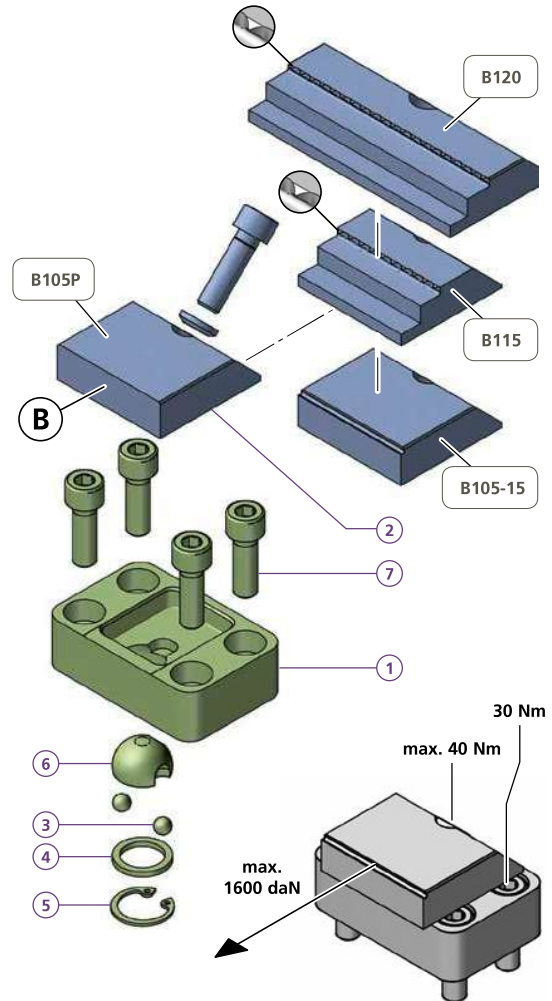

VS1X68L20-105	
1	1x TB150170
2	1x powerCLAMP p 82 - 85
3	1x BN869d=6
4	1x TN100747
5	1x TN100779
6	1x PCKMR45M8
7	4x M8X20ISO4762
kg	~0,42

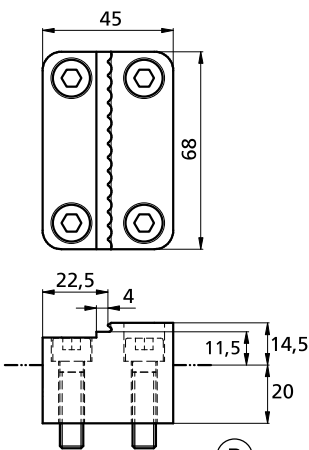

VA168-20PRG	
8	1x TH160280
9	4x M8X30ISO4762
kg	~0,75

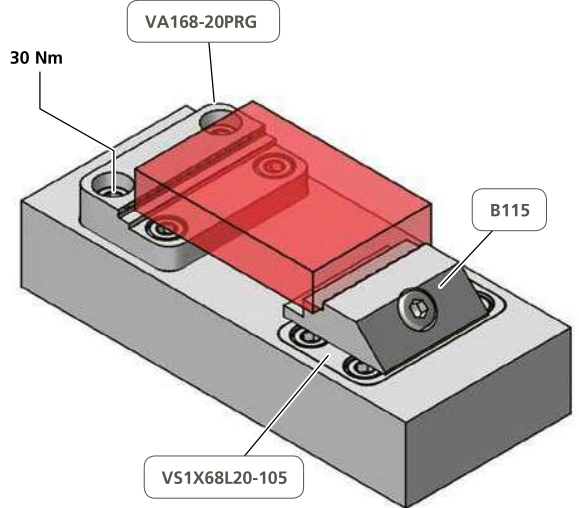
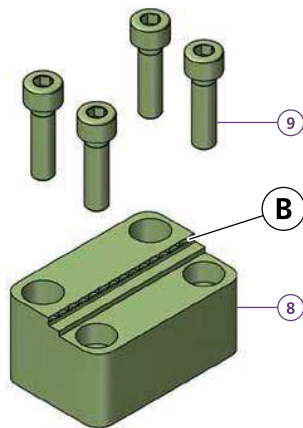

Bestellbeispiel / Ordering example: 1x VS1X68L20-105 & 1x B105P

Separat bestellen / Separate order

VS1F48L50-105

VS1P48L50-105

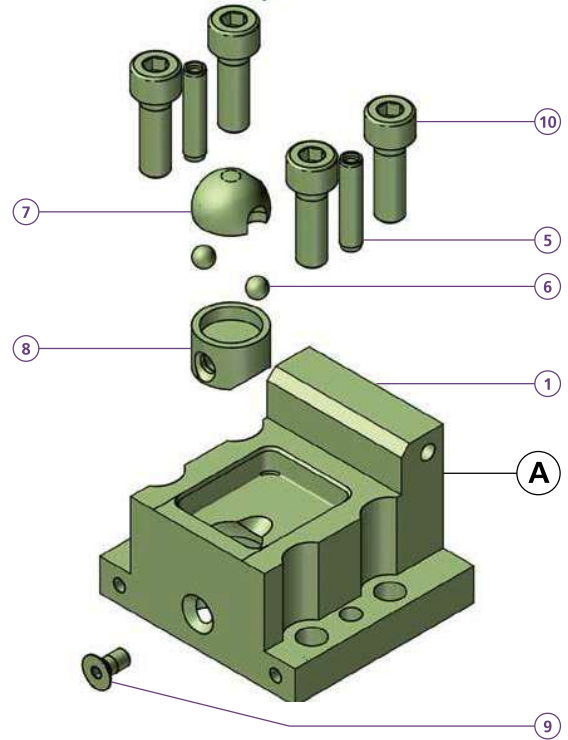
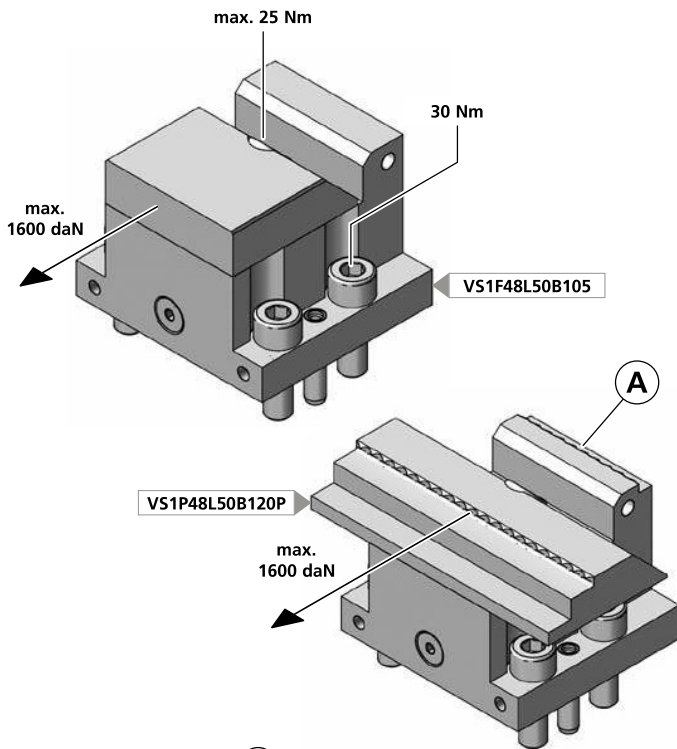
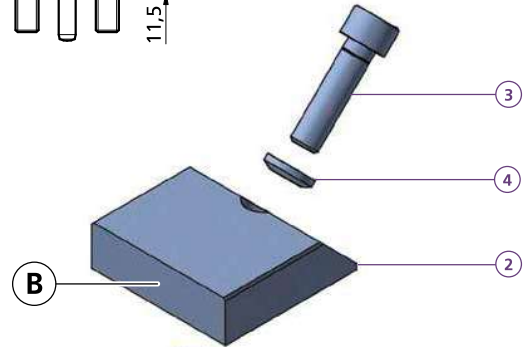
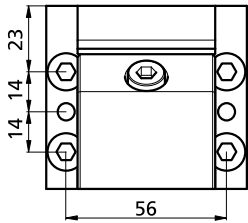
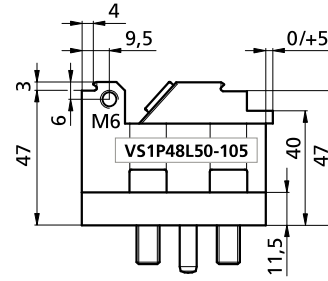
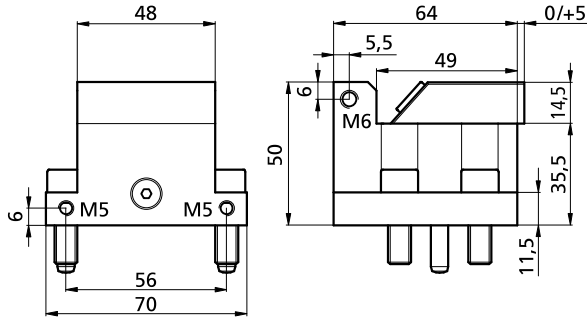

VS1F48L50-105	
1	1x TK120807
VS1P48L50-105	
1	1x TK120761
2	1x powerCLAMP p. 82 - 85
3	1x M8X30ISO4762
4	1x PCUSR14
5	1x 6-m6x26 DIN 79790
6	2x BN869d=6
7	1x PCKMR45M8
8	2x TS120001-04
9	1x M5X10DIN7991
10	4x M8X25ISO4762
kg	~1,21





Bestellbeispiel / Ordering example: 1x VS1F48L50-105 & 1x B105

Separat bestellen / Separate order

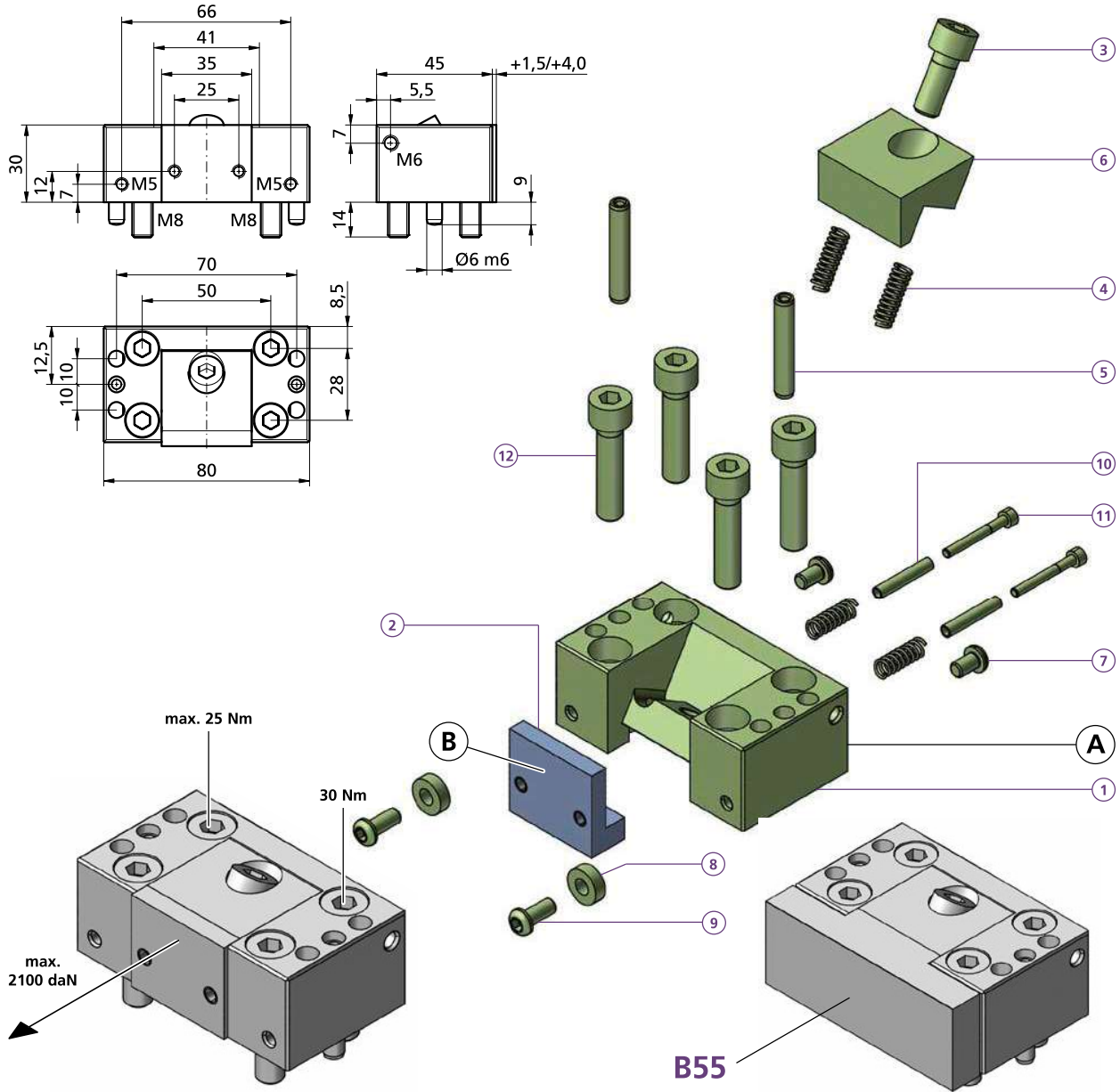



VS1R/F80L30-51

microCLAMP



		
VS1F80L30-51		
① 1x TF140731		
VS1R80L30-51		
① 1x TF140732		
② 1x		
③ 1x M8X20ISO4762		
④ 4x FED0618		
⑤ 2x CCBO0801		
⑥ 1x B78		
⑦ 2x M5X8ISO7380		
⑧ 2x CCD004		
⑨ 2x M5X12ISO7380		
⑩ 2x CCD422		
⑪ 2x M3X25ISO4762		
⑫ 4x M8X35ISO4762		
kg ~0,74		

Bestellbeispiel / Ordering example: 1x VS1R80L30-51 & 1x B52

					
C	35	35	35	35	80
H	30	30	30	35	30
L	6	6	10	10	11,5
D	-	-	-	-	-
e	-	-	-	-	-
i	HV700	HV700	*	*	*
	x0,2mm	x0,2mm			
kg	~0,06	~0,06	~0,06	~0,12	~0,27

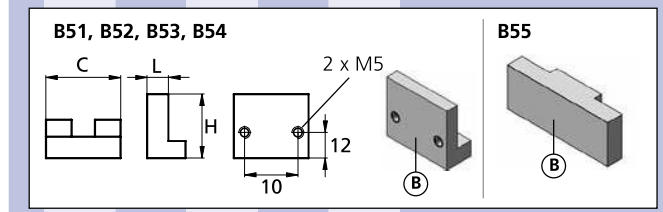

* = weicher Stahl / soft steel

Separat bestellen / Separate order

VS1X59L60K

microCLAMP

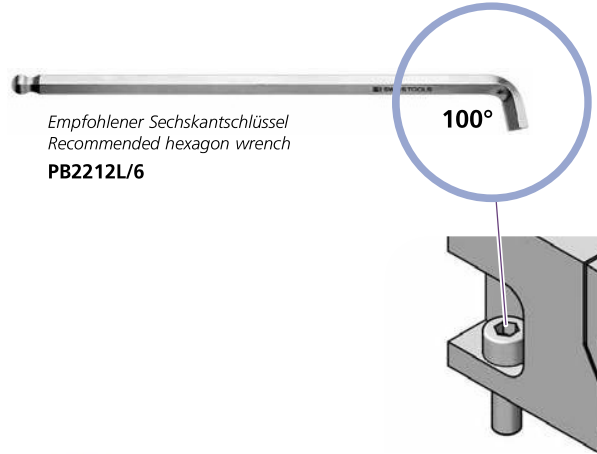
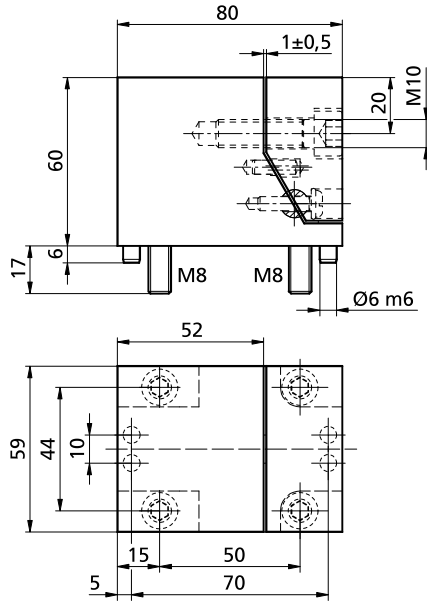

Empfohlener Sechskantschlüssel
Recommended hexagon wrench
PB2212L/6

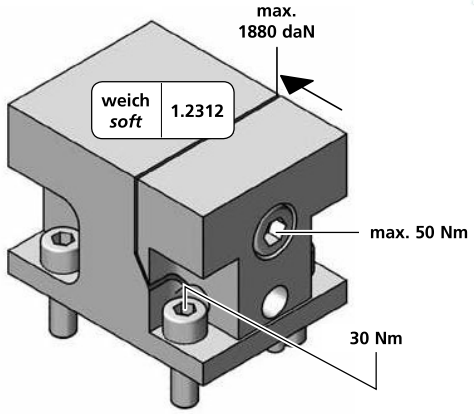
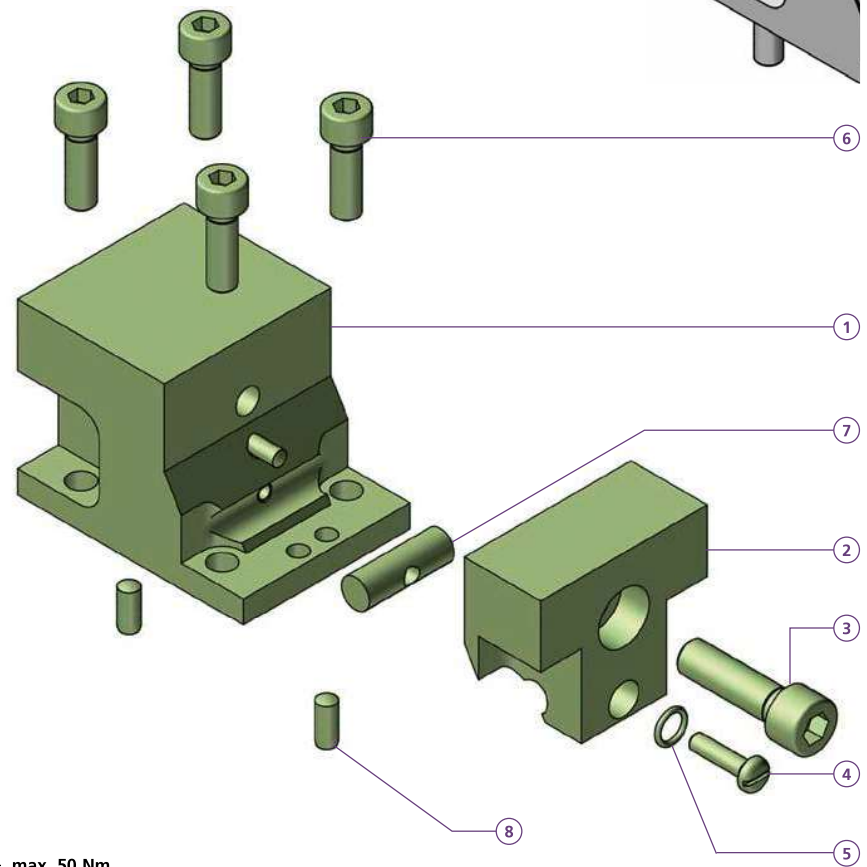

Spannstelle an Werkstück
angepasst und nitriert.
Clamping face machined to
the shape of the workpiece
and nitrided.

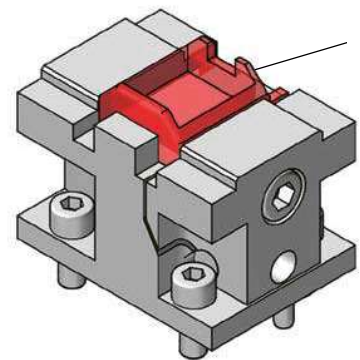

*VS1X59L60K	
①	1x VS1X59L60H5KA
②	1x VS1X59L60H5KS
③	1x M10X35ISO4762
④	1x M5X20DIN85A
⑤	1x ORØ8x1,5
⑥	4x M8X25ISO4762
⑦	1x VS1X59L60H5KG
⑧	2x 6m6x14 DIN 6325
kg	~1,89



VS1X59L60H5

microCLAMP

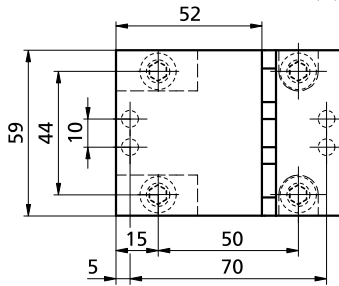
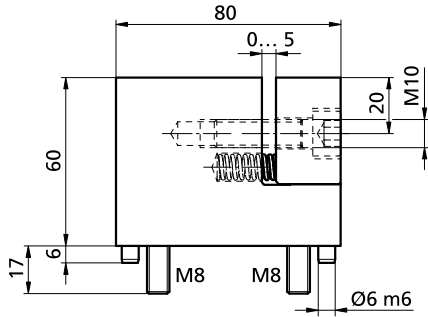

Empfohlener Sechskantschlüssel
Recommended hexagon wrench
PB2212L/6

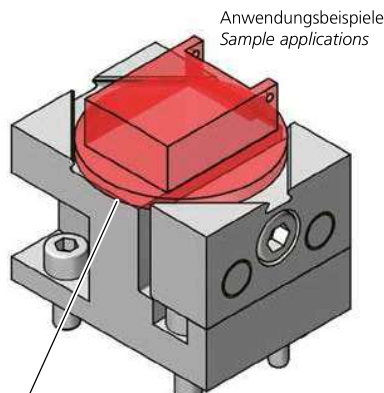
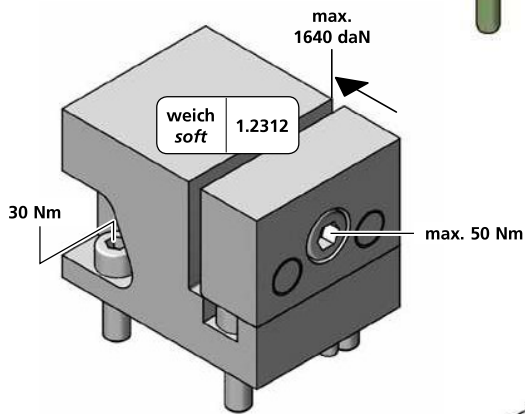
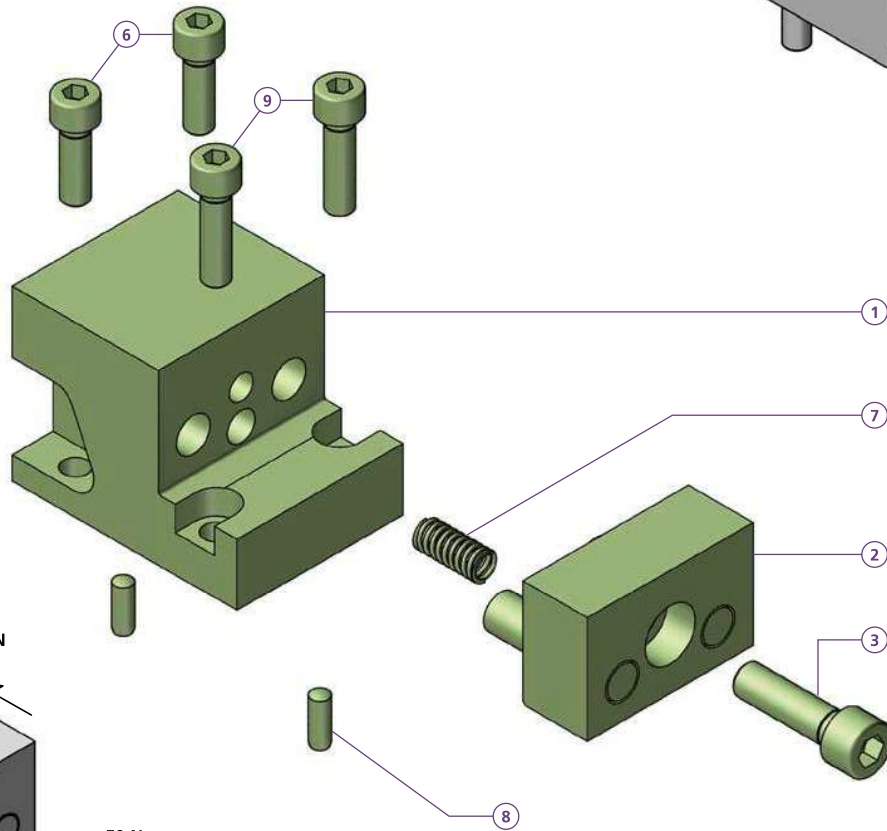
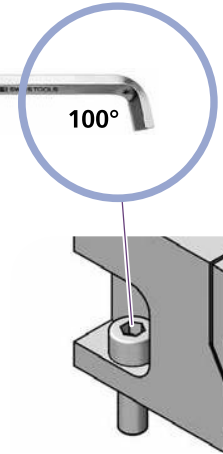

Anwendungsbeispiele
Sample applications

Spannstelle an Werkstück angepasst und nitriert.
Clamping face machined to the shape of the workpiece and nitrided.

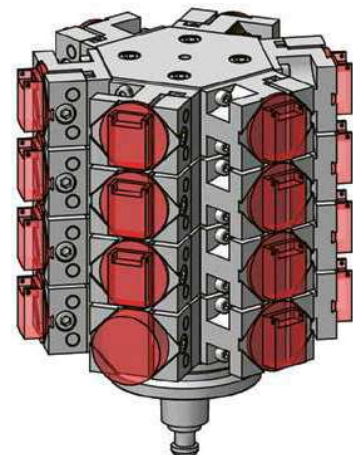

*VS1X59L60H5	
1	1x VS1X59L60H5A
2	1x VS1X59L60H5S
3	1x M10X35ISO4762
6	2x M8X25ISO4762
7	1x FED0833
8	2x 6m6x14 DIN 6325
9	2x M8X30ISO4762
kg	~1,94

* = Stahl / steel 1.2312

Bestellbeispiel / Ordering example : **VS1X59L60H5**

Separat bestellen / Separate order



durchgehärtet / through hardened					nitriert / nitrated														
26mm	B	H	N	kg	41mm	B	H	N	kg	23mm	B	H	N	kg	41mm	B	H	N	kg
CCU15026	26	15	2,2	~0,017	CCU15081	41	15	2,2	~0,018	MCU11037	23	11	2	~0,004	CCU15083	41	15	3	~0,025
CCU20026	26	20	2,2	~0,02	CCU20081	41	20	2,2	~0,022	MCU15037	23	15	2	~0,006	CCU20083	41	20	3	~0,029
CCU25026	26	25	2,2	~0,022	CCU25081	41	25	2,2	~0,025	MCU18037	23	18	2	~0,008	CCU25083	41	25	3	~0,034
CCU30026	26	30	2,2	~0,025	CCU27581	41	27	2,2	~0,027	MCU20037	23	20	2	~0,008	CCU27583	41	27,5	3	~0,036
CCU32526	26	32,5	2,2	~0,026	CCU30081	41	30	2,2	~0,029	MCU22537	23	22,5	2	~0,008					
38mm	B	H	N	kg	80mm	B	H	N	kg	26mm	B	H	N	kg	80mm	B	H	N	kg
CCU30039	38	30	2,2	~0,028	CCU15080	79	15	2,2	~0,019	CCU15027	26	15	3	~0,024	CCU15082	79	15	3	~0,026
CCU35039	38	35	2,2	~0,031	CCU20080	79	20	2,2	~0,027	CCU20027	26	20	3	~0,027	CCU20082	79	20	3	~0,036
CCU40039	38	40	2,2	~0,035	CCU25080	79	25	2,2	~0,035	CCU25027	26	25	3	~0,03	CCU25082	79	25	3	~0,045
CCU45039	38	45	2,2	~0,039	CCU27580	79	27,5	2,2	~0,039	CCU30027	26	30	3	~0,033	CCU27582	79	27,5	3	~0,049
					CCU30080	79	30	2,2	~0,043	CCU32527	26	32,5	3	~0,034					
					CCU35080	79	35	2,2	~0,05										
					CCU40080	79	40	2,2	~0,057										
					CCU45080	79	45	2,2	~0,063										

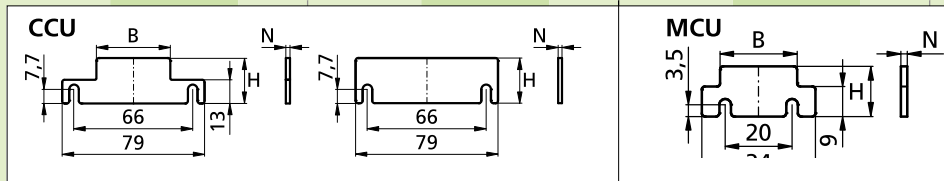

Schraubenzieher mit Konterung für
Screwdriver with holding sleeve for



CCBXSX

Positionsbolzen
Position pin

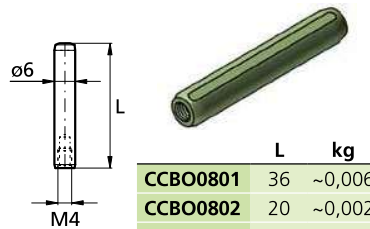

Bolzen-Auszieher
Pin puller

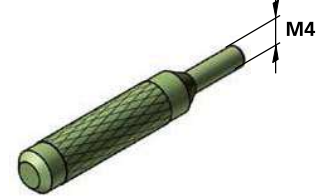

CCAZ1050

Positionierstift (spreizbar)
Locating pin (expandable)

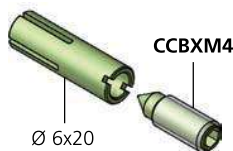

CCBX0802

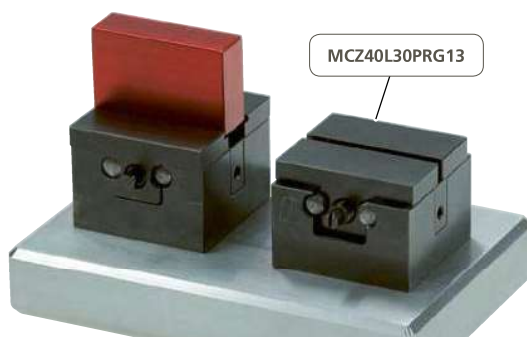

Mehr Informationen siehe Zentrischspanner
For more information check the self centring vise

p. 116



Mehr Informationen siehe Zentrischspanner
For more information check the self centring vise

p. 127



Universalbacke / Universal jaw

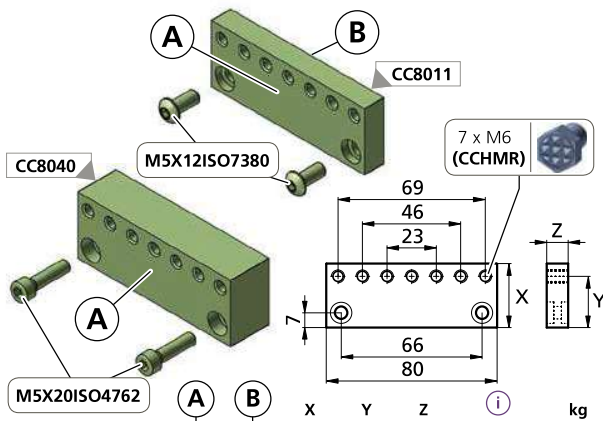

	A	B	X	Y	Z	(i)	kg
CC8011			30	24	10	56 HRC	~ 0,15
CC8025			50	44	10		~ 0,28
CC8040			30	24	20	*	~ 0,33

Weiche Backe / Soft jaw

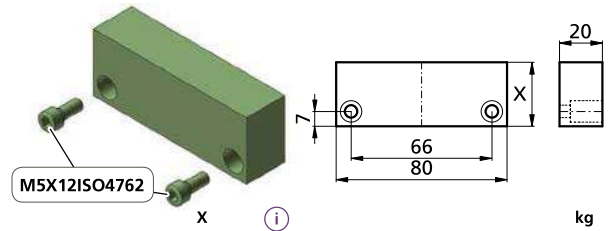

*CC8030	30	1.1191	~ 0,35
*CC8050	50		~ 0,59

**Backe mit 2 Pendeldruckstücken
Jaw with 2 swiveling balls**

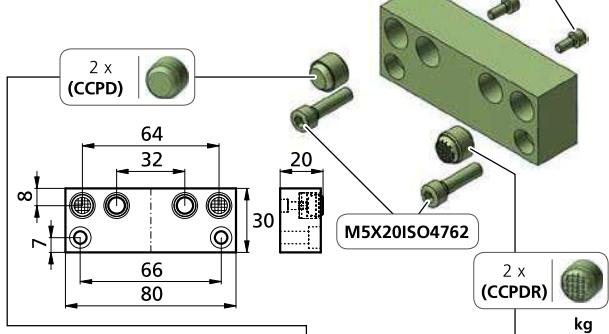

CC8060			~ 0,30
CC8060R			~ 0,30

Backe für Druckstift / Jaw for pressure pin

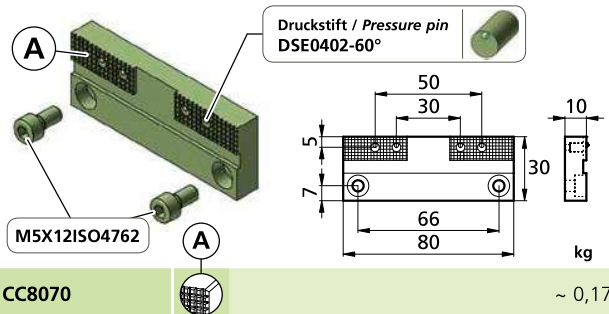

CC8070			~ 0,17
--------	--	--	--------

Prismabacke / Prismatic jaw

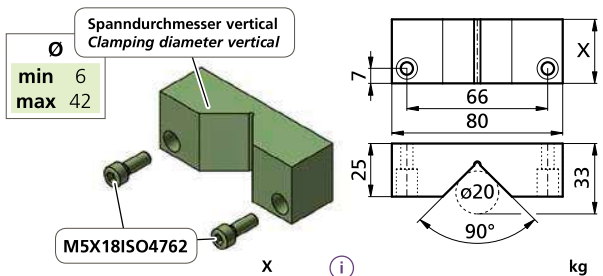

CC8050V90	30	56 HRC	~ 0,38
-----------	----	--------	--------

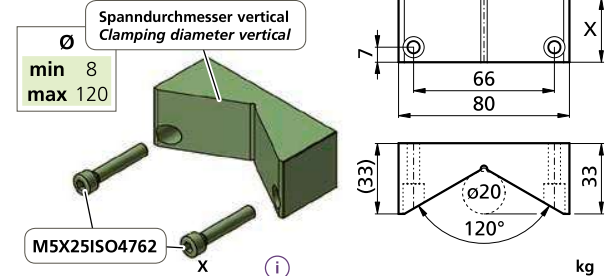

CC8050V120	30	56 HRC	~ 0,41
------------	----	--------	--------

Backe / Jaw

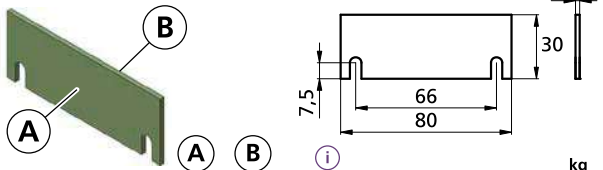

CC8210			HV700 x 0,2mm	~ 0,03
CC8211				

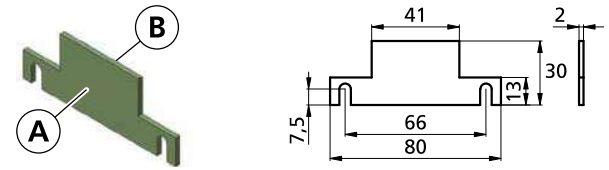

CC8220			HV700 x 0,2mm	~ 0,02
--------	--	--	---------------	--------

* = weicher Stahl / soft steel

Bestellbeispiel / Ordering example: CC8011

Separat bestellen / Separate order



microCLAMP

